

# CONTINENTAL EDISON CEHDI9450FULLIX

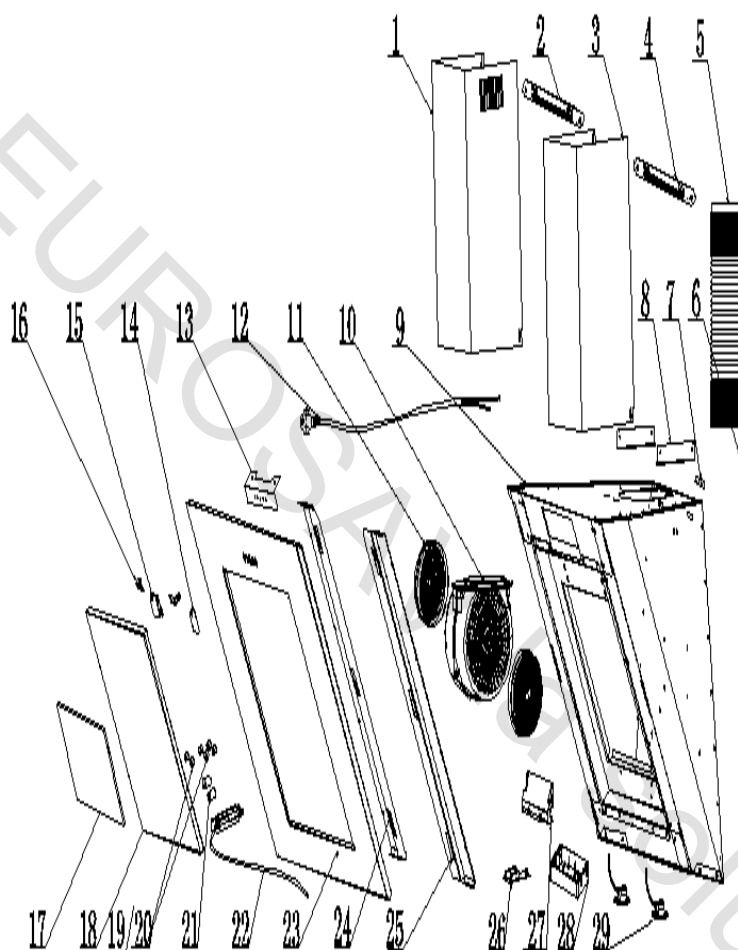

## Vue GENERALE

POS	DESIGNATION	REFERENCE	QTE
1	CHEMINEE SUPERIEURE 400mm	B202201004P	1
2	PLAQUE FIXATION CONDUIT SUPERIEUR	B232201008P	1
3	CHEMINEE INFERIEURE 400mm	B202201006P	1
4	PLAQUE FIXATION CONDUIT INFERIEUR	B232201010P	1
5	CONDUIT D' EVACUATION	B3622010400	1
6	CABLE D' ECLAIRAGE	B6224010040	1
7	FIXATION DE CABLAGE	B3022010680	1
8	FIXATION DE CONDUIT	B232705008P	2
9	CAISSON	B1127250703D	1
10	MOTEUR COMPLET	B764507001B	1
11	FILTRE CHARBON	B3522011490	2
12	CORDON D' ALIMENTATION	B6227050320	1
13	SUPPORT DE CLAVIER	B232501161P	1
14	CHARNIERE GAUCHE	B202725B003P	1
15	CHARNIERE DROITE	B202725B004P	1
16	SUPPORT CHARNIERE	B202725B007P	2
17	FILTRE METALLIQUE	B3527250430	1
18	FACADE INTERNE	B202725B002P	1
19	AIMANT DE FACADE	B2927030160	2
20	RONDELLE DE FIXATION	B3027030580	6
21	TAMPON SILICONE	B3227030170	2
22	ENSEMBLE BOUTONS POUSSOIRS	B764201002B	1
23	ENCADREMENT DE FACADE	B202725B010P	1
24	TRAVERSE LATERALE GAUCHE	B232725B011P	1
25	TRAVERSE LATERALE DROITE	B232725B013P	1
26	CONNECTEUR	B6325010440	1
27	COUVERCLE DE BOITIER	B3023011400	1
28	BOITIER MOTEUR	B3023011390	1
29	LAMPE D' ECLAIRAGE	B6224010500	2
30	ADAPTATEUR DE CONDUIT	B3025020150	1

## Vue MOTEUR

1	CARTER MOTEUR GAUCHE	B3025070010	1
2	TURBINE DE VENTILATION	B3025070030	1
3	MOTEUR	B6124012700	1
4	CARTER MOTEUR DROIT	B3025070020	1
5	FIXATION DE CARTER MOTEUR	B3022010680	1
6	CLAPET ANTI-RETOUR	B3025070040	2

## Vue CLAVIER

1	COUVERCLE DE BOITIER	B3022010900	1
2	CLAVIER DE COMMANDE	B6024011950	1
3	BOITIER DE CLAVIER	B3022010890	1
4	CABLE DE CLAVIER	B6222010930	1

## Vue CHASSIS

1	CADRE SUPPORT FILTRE METAL	B212725073P	1
2	COTE GAUCHE	B212725008P	1
3	COTE DROIT	B212725009P	1
4	ENTOURAGE DE CAISSON	B212725072P	1
5	TRAVERSE SUPERIEURE	B212725074P	1
6	PROTECTION SUPERIEURE	B212725051P	2

For r

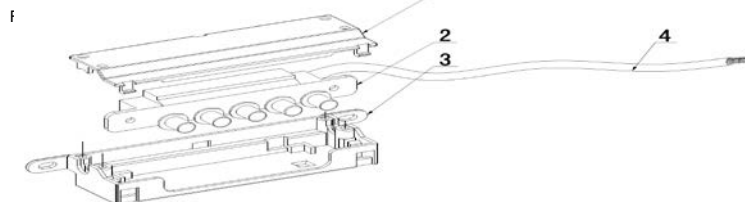
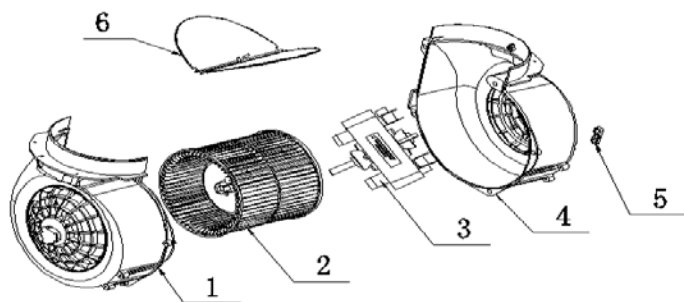

For

