

CODE	Designation
ACL	Live(Alternating Current)
ACN	Neutra(Alternating Current)
E	Earth
D/Ed	Dispenser
EV1	Inlet Valve
EV2	Softener Valve
VM	Auto open door vax motor
IAQS	Overflow Switch
FM	Flow Meter
P2	Dry Heating Protect Switch
ISB	Rinse Aid Detector
ISS	Salt Detector
ML	Wash Pump
C	Capacitor
PS	Drain Pump
FAN	Fan
FUSE	Fuse(3.15A)
R	Heater
DOOR	Door Switch
IS	Door Switch
RE	Temperature sensor(NTC)

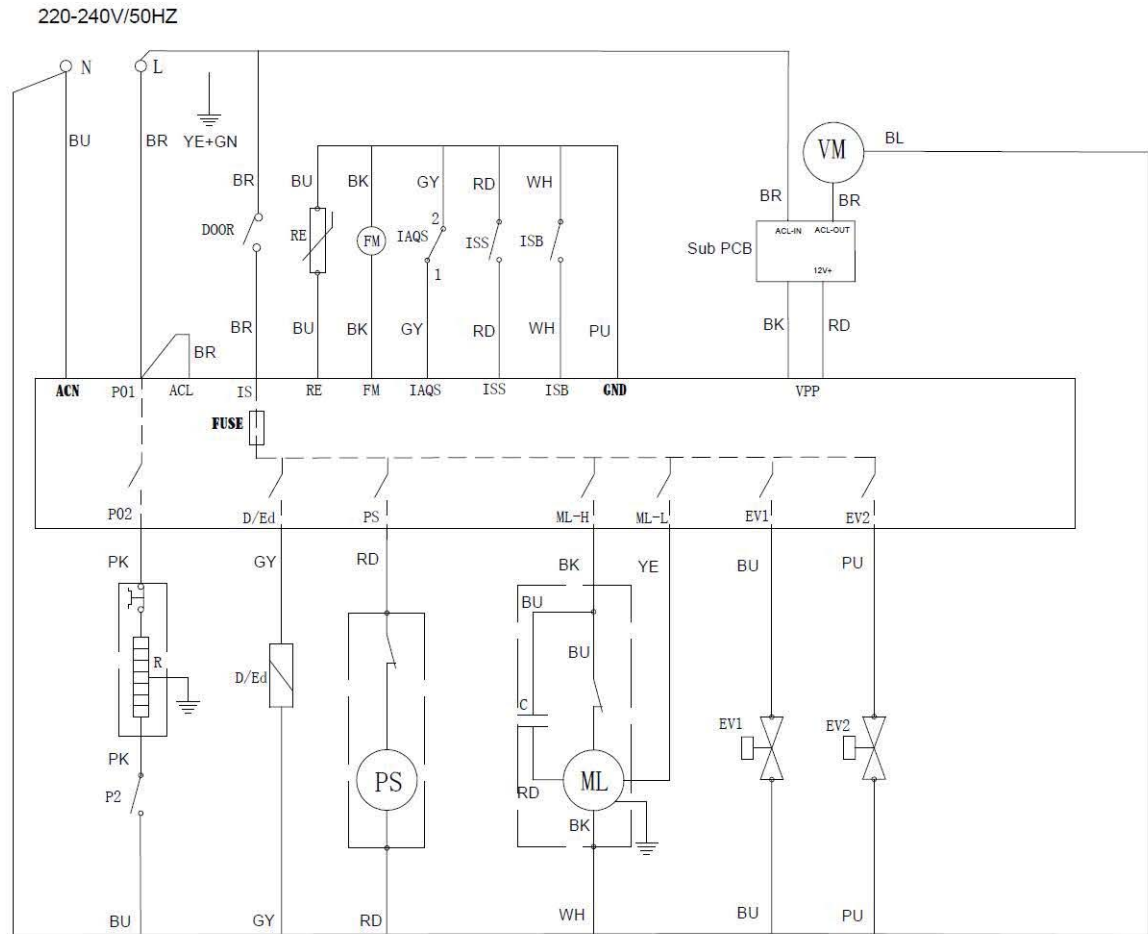

CODE	Designation	CODE	Designation
BU	Blue	PK	Pink
YE	Yellow	GY	Gray
GN	Green	OR	Orange
WH	White	BR	Brown
RD	Red	PU	Purple
BK	Black	YE+GN	Yellow+Green bicolor