

# Haier SERVICE MANUAL

Order No. Ref1004S004V0

**Chest Freezer**

**MODEL: CC320A+**



## **WARNING**

This service information is designed for experienced repair technicians only and is not designed for use by the general public. It does not contain warnings and cautions to advise non-technical individuals of potential dangers in attempting to service a product. Product powered by electricity should be serviced or repaired only by experienced professional technicians. Any attempt to service or repair the product or products dealt with in this service information by anyone else could result in serious injury or death.

2010 (HAIER ELECTRICAL APPLIANCES COR. LTD)

All right reserved. Unauthorized copying and distribution is a violation of law.

---

**Haier Group**

## Contents

Table of Contents .....	2
<b>1. General Information</b> .....	<b>4</b>
1-1. General guideline .....	4
1-2. Insurance Test.....	4
1-3. How to read this Service Manual.....	5
<b>2. Product Feature</b> .....	<b>6</b>
2-1. Specifications .....	6
2-2. External views .....	8
<b>3. Installation, adjustments and maintenance</b> .....	<b>9</b>
3-1. Installation .....	9
3-2. Defrosting and draining .....	9
3-3. Cleaning your freezer .....	10
<b>4. Disassembly</b> .....	<b>11</b>
4-1. Door assembly (Door, hinge, hinge cover) .....	11
4-2. Compartment Grill assembly .....	11
4-3. Control panel assembly (Panel, cover board, knob, indicator light) .....	12
4-4. Thermostat assembly .....	13
<b>5. Control and display system</b> .....	<b>14</b>
5-1. Control and display panel.....	14
5-2. Starting the Freezer.....	14
<b>6. System flow principle</b> .....	<b>15</b>
6-1. Refrigeration flow chart .....	15
6-2. Refrigeration flow scenograph .....	16
<b>7. Circuit diagram</b> .....	<b>17</b>
7-1. Brief principle diagram .....	17
<b>8. Trouble shooting</b> .....	<b>18</b>
8-1. Normal phenomena .....	18
8-2. Abnormal phenomena .....	20

# SERVICE MANUAL

Model: CC320A+

Issue	2010-4-12
Rev.	Ref1004S004V0

---

8-2-1. Compressor doesn't start .....	20
8-2-2. Poor cooling.....	21

## Chapter 1 General Information

### 1-1. General Guidelines

When servicing, observe the original lead dress. If a short circuit is found, replace all parts which have been overheated or damaged by the short circuit. After servicing, see to it that all the protective devices such as insulation barriers, insulation papers shields are properly installed. After servicing, make the following leakage current checks to prevent the customer from being exposed to shock hazards.

- 1) Leakage Current Cold Check
- 2) Leakage Current Hot Check
- 3) Prevention of Electro Static Discharge (ESD) to Electrostatic Sensitive

### 1-2. Insurance Test

1. Check if there is any leak of current.
2. Cut out the power supply before the repair to avoid an electrical shock hazard.
3. In the case of a live-line test, insulating gloves should be worn to avoid potential electrical shock.
4. Confirm the rated current, voltage and capacity before testing with any kinds of instruments.
5. Watch if the upper door is open when you check something at a lower position.
6. Take out every part in the cabinet before moving the machine, especially things like panels (e.g. glass shelf).
7. Please wear intact cotton gloves when repair any parts of the evaporator, so that scratches by the sharp fins can be avoided.
8. If there is a breakdown with the refrigeration system, please surrender the machine to the service center, else the leaked refrigerant may pollute the atmosphere.
9. The refrigerator use AC of 220V with a frequency of 60Hz.
10. A big fluctuation of voltage (exceed the range 187 ~ 242V) may cause a start failure of the refrigerator, a burn-out of the control panel and compressor, or an abnormal sound from the compressor in operation.
11. Take care not to damage the supply line. Don't yank at the line; pull the plug out gently from the receptacle. Don't press the line under the cabinet or step on it. Take care not to roll on or damage the supply line when moves the machine from the wall.

Issue	2010-4-12
Rev.	Ref1004S004V0

12. In the case of leakage of inflammable gases like carbon monoxide, open the door and windows. Don't pull out or insert the plugs of the appliance.
13. Don't touch the refrigeration surface of the freezing compartment when the refrigerator is in operation, especially when your hand is wet, else you may be glued to the surface.
14. Pull out the plug of power supply during clearance or power outage. Wait at least five minutes to resume the power supply in order to prevent damage to the compressor caused by continuous restart.

## 1-2-2. Photo used in this manual

The illustration and photos used in this Manual may not base on the final design of products, which may differ from your products in some way.

## 1-3. How to read this Service Manual

### 1-3-1. Using Icons

Icons are used to attract the attention of the reader to specific information. The meaning of each icon is described in the table below:

**Note:** 

A "note" provides information that is not indispensable, but may nevertheless be valuable to the reader, such as tips and tricks.

**Caution:** 

A "caution" is used when there is danger that the reader, through incorrect manipulation, may damage equipment, loose data, get an unexpected result or has to restart (part of) a procedure.

**Warning:** 

A "warning" is used when there is danger of personal injury.

**Reference:** 

A "reference" guides the reader to other places in this binder or in this manual, where he/she will find additional information on a specific topic.

## 2-1. SPECIFICATIONS

CHEST FREEZER		
Superfast freeze function. Adjustable temperature control with power indicator. High pressure and microbiological foam filled door for energy conservation. convenient water drain. Hi-temp indicator. External controls.		
<i>Last update</i>		2010-4-12
<b>1. Type Model</b>		<b>CC320A+</b>
Commercial brand		<b>Haier</b>
Product description		<b>Chest Freezer</b>
Type of appliance (FS=free standing / BI= built-in)		<b>FS</b>
Energy efficiency class		<b>A+</b>
Climate class (N=16-32 ST=16-38 T=18-43 )		<b>SN~T</b>
Freezer star rating		<b>*/***</b>
Approvals (VDE / TÜV / IMQ / NF / ÖVE / DEMKO etc.)		<b>CE/GS</b>
Certifications		<b>-</b>
<b>2. Key features</b>		
Gross capacity	l	<b>324</b>
Total net capacity	l	<b>319</b>
Freezing capacity ( kg/24h )	kg/24h	<b>20</b>
Energy consumption/year	kWh/year	<b>283</b>
Max storage time at breakdown	h	<b>35</b>
Defrosting (Manual-Automatic)		<b>Manual</b>
Kind of coolant (R134a/R600a)		<b>R600a</b>
Foaming components (R141b/C-P)		<b>C-P</b>
<b>3. Technical data</b>		
Voltage / frequency	V/Hz	<b>220-240~/50</b>
Input power / currency	W /A	<b>120/1.2</b>
Lenght of cable / incl. plug	cm	<b>150/155</b>
Temperature range (from>to)	°C	<b>-18</b>
DIN 8950 resp. 8953		<b>-</b>
Energy consumption / year	kWh/year	<b>283</b>
Energy consumption (EN153) per 24 h	kWh/24 h	<b>0.775</b>
Cooling system: (K=Compressor / A=Absorbtion)		<b>K</b>
Maximum noise level	dB(A)	<b>40</b>
<b>4. Aesthetics</b>		
Door		<b>Streamline</b>
Chest		<b>Streamline edges</b>
Colours:		

# SERVICE MANUAL

Model: CC320A+

Issue	2010-4-12
Rev.	Ref1004S004V0

7

Cabinet			white
Top			white
Door glass			-
Door frame			white
Fascia panel / Handle (w/b/g/s)			white/white
Inside door/-drawers (W=white T=transparent)			-/-
<b>5. Equipment &amp; accessories</b>			
Product classification (Super eco/Eco/Standard)			Standard
Lid (Number/Handle/Lock)			1/ /
Type of lid (Hinge/Counter balanced/Sliding)			Hinge
Inside walls (Stainless steel/Aluminium/Synthetic mat.)			Anodized Aluminum
Insulation Lid thickness	cm		7.8
Walls thickness	cm		7
Baskets number	n°		2(metal)
Defrost drain			
Interior light			
Calendar			-
Adjustable thermostat			
Fast freeze lamp (yellow)			
On light (green)			
Breakdown light (red)			
Fast freeze switch			
Freezer temperature warning indicator (LED / by sound)			-
Thermometer (Outside / In partition)			-
Maximum loading level marking			-
Adjustable feet (front / rear)	n°		-(unable adjustable feet)
Mobility wheels (front / rear)	n°		-
Flush back skin evaporator			-
<b>6. Product net dimensions</b>			
Unit dimensions (H / W / D)	cm		85.5/105.5/74.5
Height with open lid	cm		-
Net weight	kg		51
<b>7. Packing dimensions &amp; loadability</b>			
Packing dimensions (H / W / D)	cm		89.5/111.5/77.5
Gross weight	kg		58
20 ' container load	pcs		-
40 ' container load	pcs		-
40 ' High cube container load	pcs		95
85 mc (13,6 m) truck	pcs		-
120 mc jumbo truck	pcs		-
<b>8. Service</b>			
User instruction (languages)			GB(Optional)

## 2-2. External views

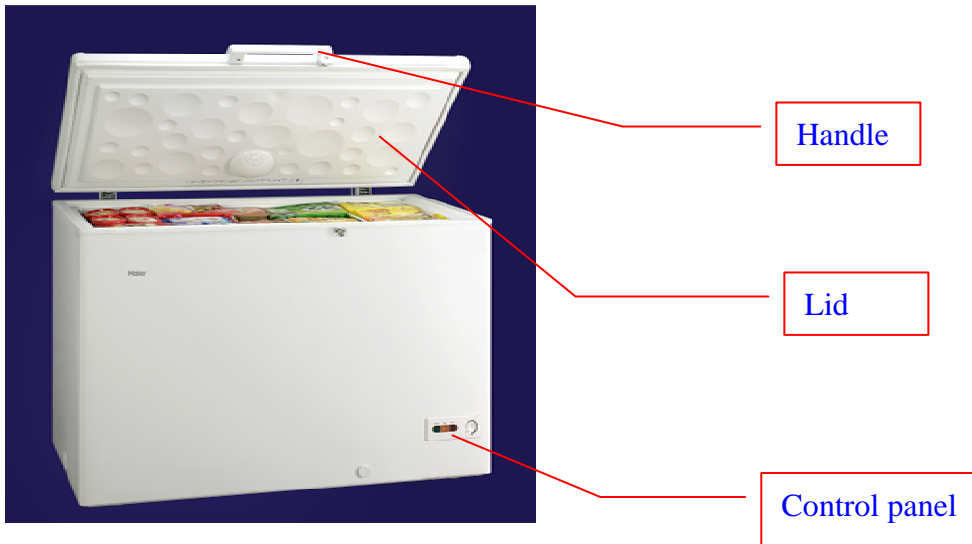

## Chapter 3 Installation, adjustments and maintenance

### 3-1. Installation

The freezer should be conveniently located for day-to-day use in a dry well-ventilated room.

Do not install the freezer where the temperature will go below 0°F or above 110°F, because it will not maintain proper temperatures.

Be sure to install the freezer on a floor strong enough to support it when it is fully loaded.

The freezer must be solidly positioned on the floor if it is to function at its best. Shims may be used to accomplish this wherever the floor is too uneven. If the place selected for the freezer is damp or moist, place 2 X 4 s (51 mm X 102 mm) under its entire length to assure adequate support.

### 3-2 Defrosting and Draining

In most climates, defrosting will be necessary only about twice a year.

To have the freezer operate most efficiently, do not permit more than 1/2" (13 mm) of frost to accumulate on the shelves.

To remove frost, scrape with a plastic or wood spatula or scraper.

Do not use an ice pick or sharp-edged instrument as it may damage or scratch the freezer.





Do not use any electrical device in defrosting your freezer.

## For Complete Defrosting

1. Turn the temperature control to the *OFF* position and unplug the freezer.

2. Remove all food and place it in corrugated boxes, insulated bags, picnic coolers, etc. Use towels and newspapers for insulation as needed.

3. With the door/lid open, use pans of hot water to speed loosening of frost. Remove large pieces before they melt.

Chest models have a defrost water drain at the front.

4. Sponge excess water from the bottom of the freezer as it collects to prevent overflowing.

5. After defrosting, clean the inside of the freezer.

6. Replace the drain plug inside the cabinet and the cap on the defrost drain. Fold over and dry the gasket on the hinge side of the lid.

7. Plug in the freezer. Return the temperature control to its previous position and return food to the freezer.



Water may drip from the back flange of the lid cover during defrosting. This is normal. Ice builds up in the lid insulation when the lid is open for adding or removing food, and melts during the defrosting operation.

## 3-3 Cleaning the Freezer

**Outside.** Protect the paint finish. The finish on the outside of the freezer is a high quality baked-on paint finish. With proper care, it will stay new-looking and rust-free for years. Apply a coat of appliance polish wax when the freezer is new and then at least twice a year. Appliance polish wax also works well to remove tape residue from freezer surfaces.

**Keep the finish clean.** Wipe with a clean cloth lightly dampened with appliance polish wax or mild liquid dishwashing detergent. Dry and polish with a clean, soft cloth. Do not wipe the freezer with a soiled dishwashing cloth or wet towel. Do not use scouring pads, powdered cleaners, bleach, or cleaners containing bleach.

**Inside.** Clean the inside of your freezer at least once a year. We recommend that the freezer be unplugged before cleaning. If this is not practical, wring excess moisture out of sponge or cloth when

cleaning in the vicinity of switches, lights or controls.

Use warm water and baking soda solution-about a tablespoon of baking soda to a quart of water. Rinse thoroughly with water and wipe dry. Do not use cleaning powders or other abrasive cleaners.

An open box of baking soda in the freezer will absorb stale freezer odors. Change the box every three months.



Care should be taken in moving the freezer away from the wall. All types of floor coverings can be damaged particularly cushioned coverings and those with embossed surfaces.

## Chapter 4 Disassembly

### 4-1. Door assembly (Door, hinge, hinge cover)

Disassemble the hinge assembly and the hinge cover: the hinge cover, take away the cover, then screw off the eight screws on the bottom hinge, so the whole hinge could be moved.



### 4.2. Compartment Grill assembly

Unscrew the two screws of grill, you can take away the grill.

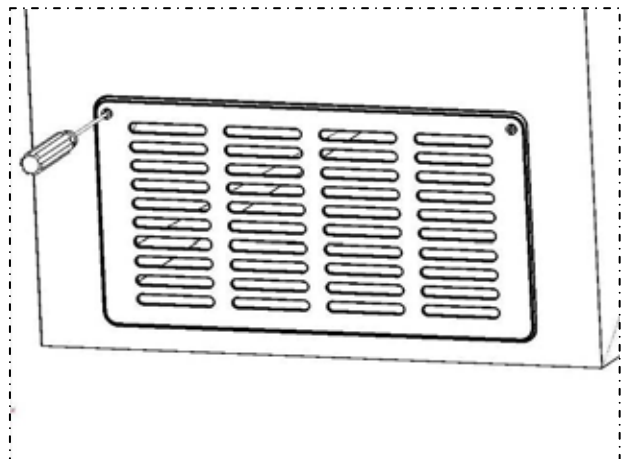

## 4-3. Control panel assembly (Panel, cover board, knob, indicator light)

Unscrew the compartment grill (refer 4-2), push the panel claw gently you're your finger or tools, at the same time pull panel outside then take away it.

Take away the knob with a sharp-edged tool.

Press the cover board and take away it.

Press two claws on indicator light side and push it from back to front.



## 4-4. Thermostat assembly

First take off the knob (refer 4-3), Use turnbuckle spanner or acutilingual plier, unscrew the turnbuckle, then thermostat can be moved from back of panel.

**Note:** When assembly thermostat you should placed thermostat in originally direction.

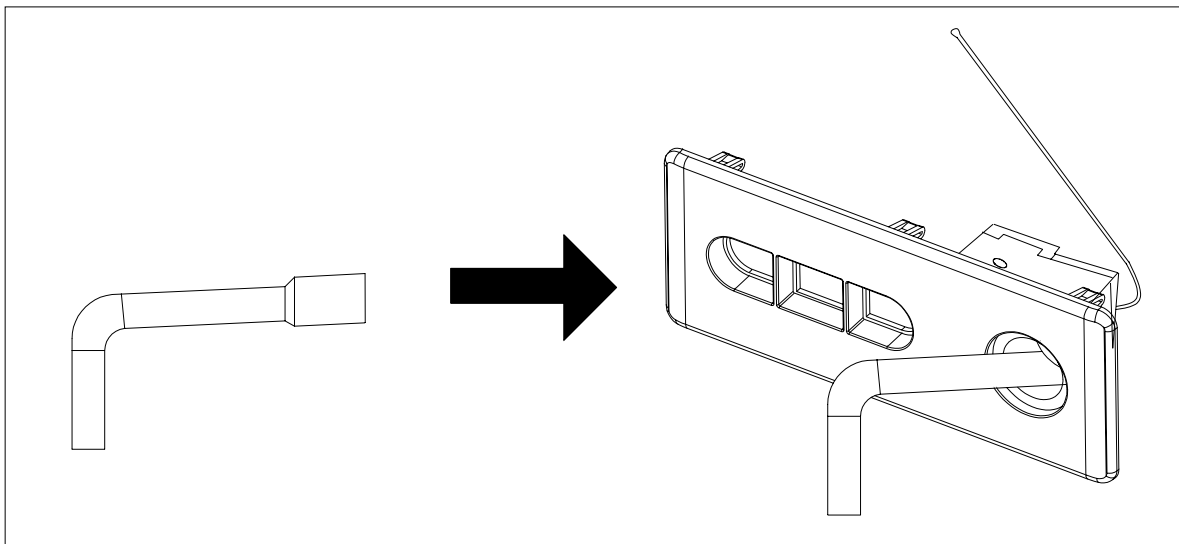

## Chapter 5 Control and display system

### 5-1. Control panel

Freezing temperature selection is made by setting the control from *min* to *max* (coldest).

If you want colder or warmer temperatures, adjust the control one step at a time.

Allow several hours after each one-step adjustment for the freezer temperature to stabilize.

### 5-2. Starting the Freezer

1. Clean the inside of the freezer with a mild solution of baking soda and water
2. Connect cord to power outlet.
3. Make sure the temperature control is set at 4.
4. Allow freezer to operate for at least four hours before placing food inside.

## Chapter 6 System flow principle

### 6-1. Refrigeration flow chart

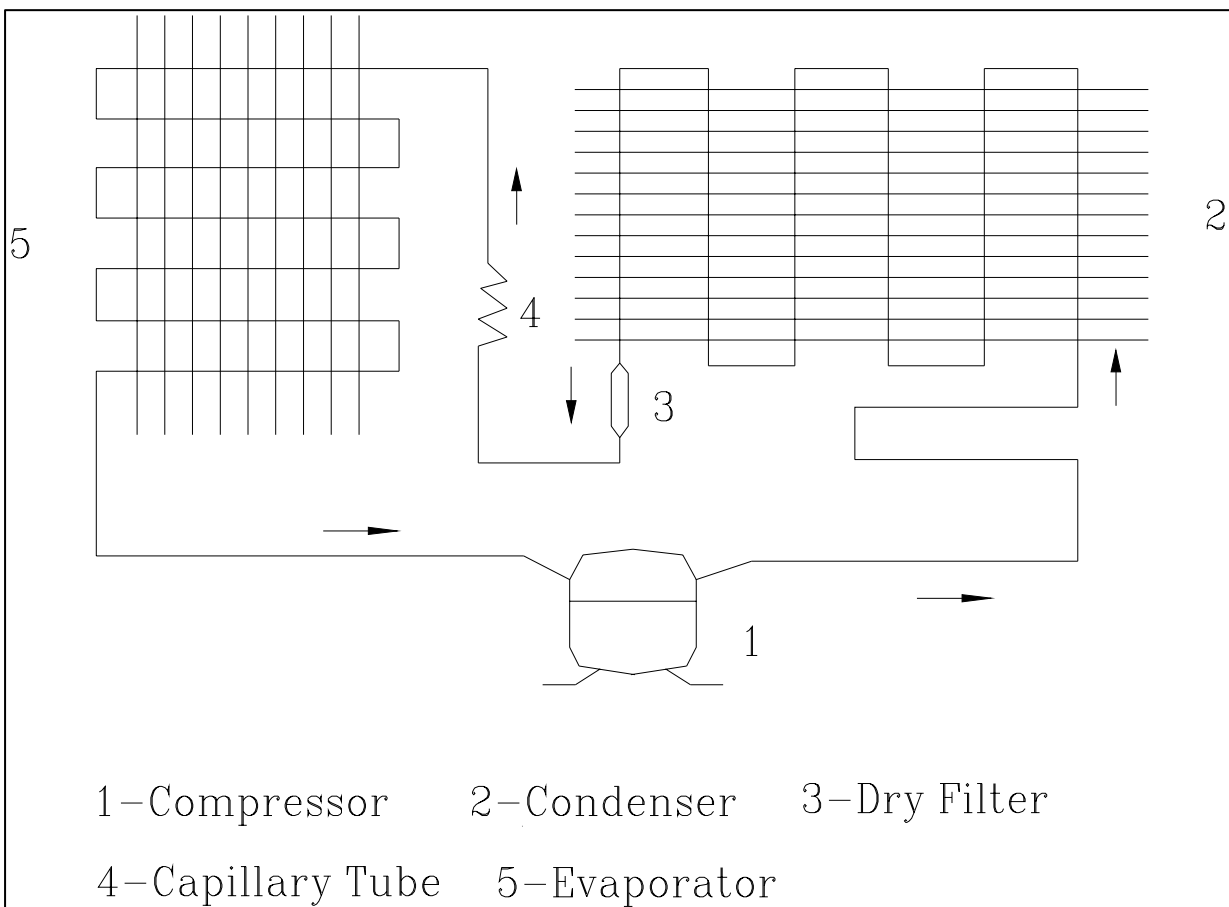

The refrigeration system of direct cooling single-system cooler belongs to the category of a single-temperature and single-control refrigerating system with one evaporators and is controlled by a single temperature control.

## 6-2. Refrigeration flow scenograph

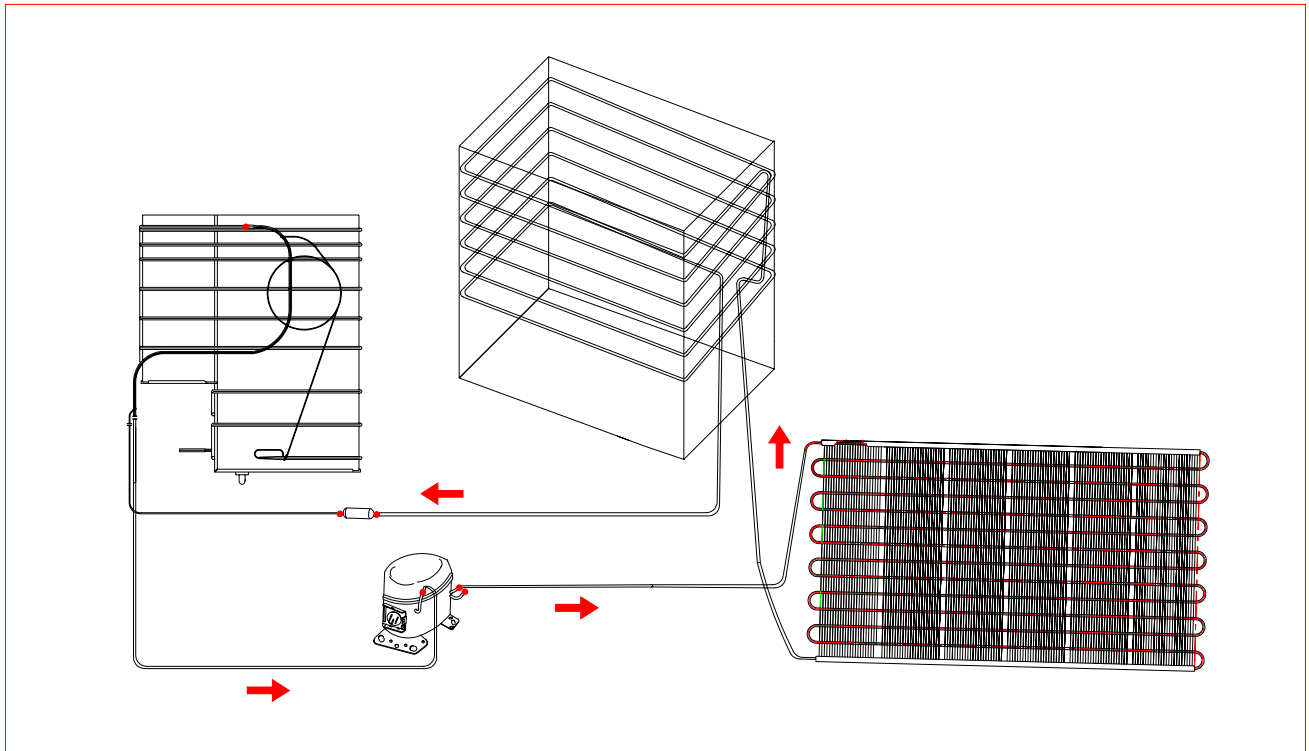

## Chapter 7 Circuit diagram

### 7-1. Brief principle diagram

<b>CONGELATEUR COFFRE</b>		<b>SCHEMA DE CIRCUIT</b> 
<b>MODELE</b> CC320A+	<b>POUVOIR DE CONGELATION</b> 20kg/24h	
<b>VOLUME NET</b> 319l	<b>CONSOMMATION D'ENERGIE</b> 283kW·h/an	XP-Fiche d'alimentation M-Compresseur SAT- Thermostat HGN- Voyant vert HYE-Voyant orange HRD-Voyant rouge F- Protecteur contre les surcharges de courant/chaueur RT- Démarreur C-Condensateur L-Lampadina  Fabriqu� en Chine SOURCECO FRANCE
<b>VOLTAGE</b> 220-240V~	<b>PUISSANCE ELECTRIQUE</b> 120W	
<b>FREQUENCE</b> 50Hz	<b>AMPERAGE</b> 1.2A	
<b>CLASSE DE PROTECTION</b> I	<b>REFRIGERANT</b> R600a 84g	
<b>POIDS NET</b> 51kg	<b>AGENT D'EXPANSION</b> CP/IP	
<b>CLASSE</b> SN,N,ST,T	<b>PUISSAVCE DE LA LAMPE</b> 15W	
Num�ro de s�rie		

## Chapter 8 Trouble shooting

### 8-1. Normal phenomena

<i>Problem</i>	<i>Possible Causes</i>	<i>What To Do</i>
<b>Freezer does not operate or Power-On Light is not on</b>	<b>Temperature control in OFF or Min or 0 position.</b>	Move the control to a temperature setting.
	<b>Freezer is unplugged.</b>	Push the plug completely into the outlet.
	<b>The fuse is blown/circuit breaker is tripped.</b>	Replace fuse or reset the breaker
<b>Freezer starts/stops too frequently</b>	<b>Door/lid left open.</b>	Check to see if package is holding door/lid open.
	<b>Too frequent or too long to door/lid openings.</b>	Closed the door or reduce the times of opening the door
	<b>Temperature control set too cold.</b>	See About the operation of your freezer
<b>Freezer operates too long</b>	<b>Door/lid left open.</b>	Check to see if package is holding door/lid open.
	<b>Too frequent or too long door/lid openings.</b>	Closed the door or reduce the times of opening the door
	<b>Temperature control set too cold.</b>	See About the operation of your freezer
	<b>Inadequate air circulation space around cabinet.</b>	See Preparing to install the freezer
	<b>Fast Freeze switch is in the ON position (on some models)</b>	See About the operation of your freezer
<b>Noisy operation or cabinet vibrates</b>	<b>Floor may be weak, causing freezer to vibrate when compressor is on.</b>	Placing 2 X 4s (51 mm X 102 mm) under the length of the freezer will help support it and may reduce vibration.
	<b>Cabinet is not positioned solidly on floor</b>	See Preparing to install the freezer Or use shims for uneven floor
<b>Freezer temperature too warm</b>	<b>Door/lid left open.</b>	Check to see if package is holding door/lid open.
	<b>Too frequent or too long door/lid openings.</b>	Closed the door or reduce the times of opening the door
<b>Foods</b>	<b>Temperature control OFF or Min or 0</b>	Move the control to a temperature setting.

# SERVICE MANUAL

Model: CC320A+

Issue	2010-4-12
Rev.	Ref1004S004V0

<b><i>defrosting</i></b>	<b>positions.</b>	
	<b>Freezer is unplugged.</b>	Push the plug completely into the outlet.
	<b>The fuse is blown/circuit breaker is tripped.</b>	Replace fuse or reset the breaker
	<b>Door/lid left open.</b>	Check to see if package is holding door/lid open.
	<b>Too frequent or too long door/lid openings.</b>	Closed the door or reduce the times of opening the door
<b><i>Freezer temperature too cold</i></b>	<b>Temperature control set too cold.</b>	See About the operation of your freezer
	<b>Fast Freeze switch is in the ON position or has run for too long (on some models)</b>	About the operation of your freezer
<b><i>Moisture forms on outside of cabinet</i></b>	<b>Not unusual during periods of high humidity</b>	Wipe surface
<b><i>Interior light does not work (on some models)</i></b>	<b>No power at outlet.</b>	Replace fuse or reset the breaker
	<b>Freezer is unplugged.</b>	Push the plug completely into the outlet.
	<b>Light bulb burned out.</b>	Replace bulb.
<b><i>Door/lid wont fully close by itself</i></b>	<b>Package holding door/lid open.</b>	Get rid of all the packages
<b><i>Slow starting time after being off</i></b>	<b>Built-in overload product.</b>	Refer to the manual
<b><i>Excessive frost build-up</i></b>	<b>Door/lid left open.</b>	Check to see if package is holding door/lid open.
	<b>Too frequent or too long door/lid openings.</b>	Closed the door or reduce the times of opening the door
	<b>Not unusual during periods of high humidity</b>	Defrost

## 8-2. Abnormal phenomena

### 8-2-1. Compressor doesn't start

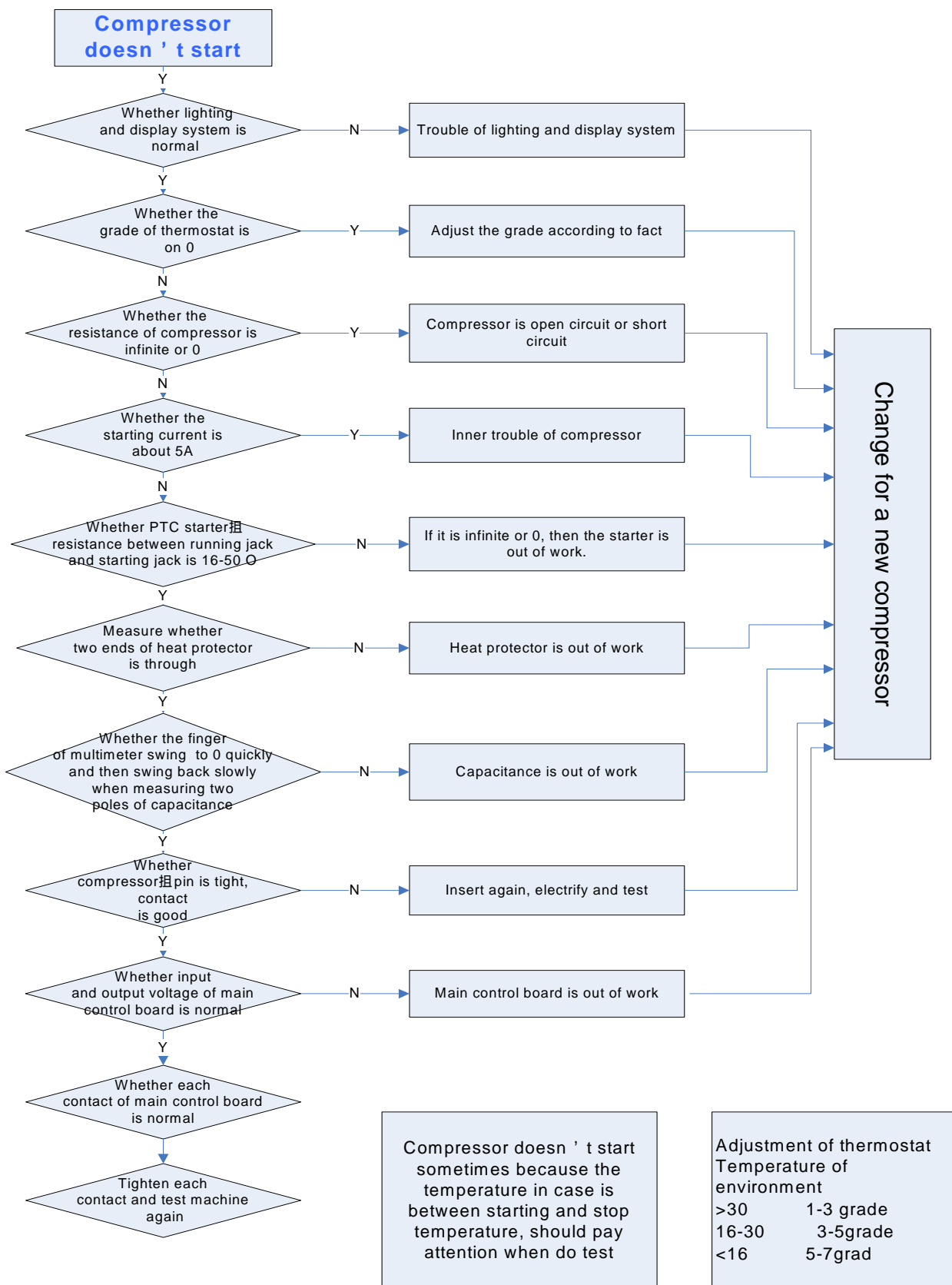



## 8-2-2.Poor cooling

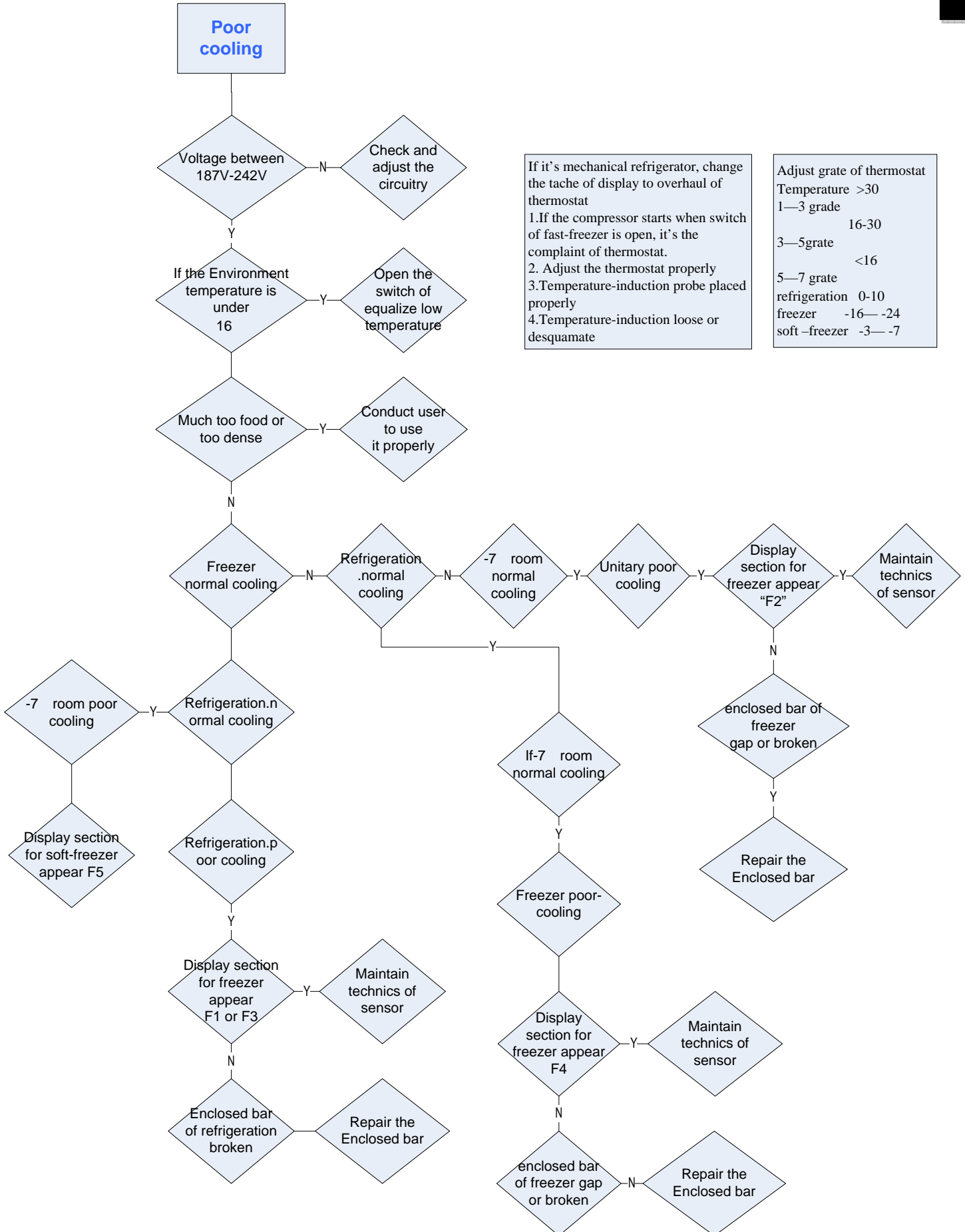

If it's mechanical refrigerator, change the tache of display to overhaul of thermostat  
 1.If the compressor starts when switch of fast-freezer is open, it's the complaint of thermostat.  
 2. Adjust the thermostat properly  
 3.Temperature-induction probe placed properly  
 4.Temperature-induction loose or desquamate

Adjust grate of thermostat	
Temperature >30	
1—3 grate	16-30
3—5grate	<16
5—7 grate	
refrigeration	0-10
freezer	-16— -24
soft -freezer	-3— -7

**Sincere forever**

**Haier Group**

**Haier Industrial Park, No.1, Haier Road**

**266101, Qingdao, China**

**<http://www.haier.com>**