

130±1

85±1

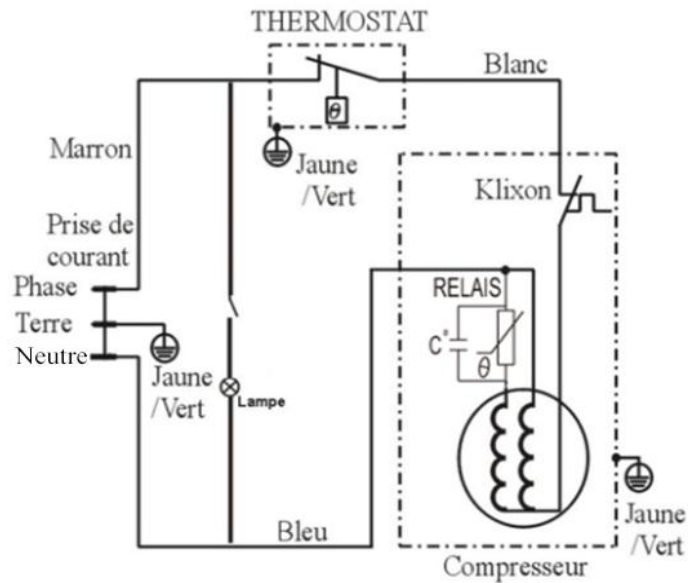

Diagramme des circuits



BUT INTERNATIONAL
1, AVENUE SPINOZA
77184 EMERAINVILLE, France
FABRIQUE EN RPC

REFRIGERATEUR

REFERENCE:	ARM2003A+
TENSION NOMINALE:	220-240V~
FREQUENCE NOMINALE:	50Hz
CONSOMMATION ENERGETIQUE	0.53kWh/24h
COURANT NOMINAL:	0.8A
PUISSANCE DE LA LAMPE:	10W
VOLUME UTILE:	181 L
CLASSE CLIMATIQUE	N/ST
GAZ REFRIGERANT	R600a(33g)
CLASSE DE PROTECTION CONTRE CHOC ELECTRIQUE	CLASSE I
POIDS NET:	34kg
MOUSSE D'ISOLATION:	CYCLOPENTANE
POUVOIR DE CONGELATION:	2.0Kg/24h
AUTONOMIE EN CAS DE COUPURE	18.4 h
NO.DE SERIE:	WWYY00001-1240

