

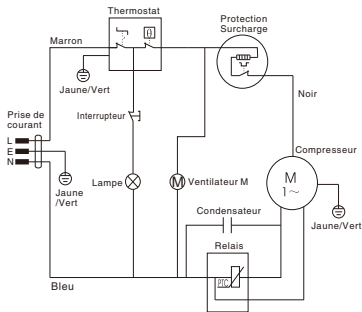

# REFRIGERATEUR 1 PORTE



REFERENCE:	AFM3502BK
TENSION NOMINALE:	220-240V~
COURANT NOMINAL:	0.55A
FREQUENCE NOMINALE:	50Hz
PUISSANCE DE LA LAMPE:	MAX 10W
VOLUME UTILE TOTAL:	335L
VOLUME UTILE DU REFRIGERATEUR:	335L
CLASSE CLIMATIQUE:	N/ST
GAZ REFRIGERANT:	R600a(45g)
CONSOMMATION D'ENERGIE DE E16:	0.162kWh/24h
CONSOMMATION D'ENERGIE DE E32:	0.626kWh/24h
CONSOMMATION D'ENERGIE ANNUELLE:	144kWh/a
CLASSE DE PROTECTION CONTRE CHOC ELECTRIQUE:	I
POIDS NET:	56.5kg
MOUSSE D'ISOLATION:	CYCLOPENTANE
CLASSE ENERGETIQUE:	F
NO. DE SERIE:	WWYY00001

BUT INTERNATIONAL  
1, AVENUE SPINOZA  
77184 EMERAINVILLE, FRANCE  
FABRIQUE EN RPC

