



USER GUIDE

AFM2204A+BK

EN



1 door
fridge

TABLE OF CONTENTS

Important safety instructions	- 30 -
Structure illustration	- 36 -
Transport and handing	- 37 -
Installation	- 37 -
First use	- 38 -
Test	- 39 -
Temperature control	- 39 -
Storage of food	- 40 -
Defrosting	- 42 -
Helpful hints and tips	- 43 -
Cleaning and care	- 44 -
Door reverse	- 47 -
Coldest zone in the refrigerator	- 49 -
Troubleshooting	- 51 -
Technical specifications	- 53 -



This product is for household use only!

Please read these instructions carefully before the first use of this product and save this manual for your future reference.

IMPORTANT SAFETY INSTRUCTIONS

This warning is only for EUROPEAN market only!

When using an electrical appliance, basic precautions should always be followed, including the following:

1. This appliance can be used by children aged from 8 years and above and persons with reduced physical, sensory or mental capabilities or lack of experience and knowledge if they have been given supervision or instruction concerning use of the appliance in a safe way and understand the hazards involved. Children shall not play with the appliance. Cleaning and user maintenance shall not be made by children without supervision.
2. Children aged from 3 to 8 years are allowed to load and unload refrigerating appliances.
3. If the supply cord is damaged, it must be replaced by the manufacturer, its service agent or similarly qualified persons in order to avoid a hazard.
4. **WARNING:** Keep ventilation openings, in the appliance enclosure or in the built-in structure, clear of obstruction.
5. **WARNING:** Do not use mechanical devices or other means to accelerate the defrosting process, other than those recommended by the manufacturer.

6. **WARNING:** Do not damage the refrigerant circuit.

7. **WARNING:** Do not use electrical appliances inside the food storage compartments of the appliance, unless they are of the type recommended by the manufacturer.

8. Do not store explosive substances such as aerosol cans with a flammable propellant in this appliance.

9. This appliance is intended to be used in household and similar applications such as

- staff kitchen areas in shops, offices and other working environments;
- farm houses and by clients in hotels, motels and other residential type environments;
- bed and breakfast type environments;
- catering and similar non-retail applications.

10. Placed the appliance against a wall with a free distance not exceeding 75 mm and more than 50mm

11. **WARNING:** When positioning the appliance, ensure the supply cord is not trapped or damaged.

12. **WARNING:** Do not locate multiple portable socket-outlets or portable power supplies at the rear of the appliance.

13. To avoid contamination of food, please respect the following instructions:

- Opening the door for long periods can cause a significant increase of the temperature in the compartments of the appliance.
- Clean regularly surfaces that can come in contact with food and accessible drainage systems.
- Clean water tanks if they have not been used for 48h; flush the water system connected to a water supply if water has not been drawn for 5 days.
- Store raw meat and fish in suitable containers in

the refrigerator, so that it is not in contact with or drip onto other food.

- Two-star frozen-food compartments are suitable for storing pre-frozen food, storing or making ice cream and making ice cubes.

- One-, two- and three-star compartments are not suitable for the freezing of fresh food.

- If the refrigerating appliance is left empty for long periods, switch off, defrost, clean, dry, and leave the door open to prevent mould developing within the appliance.

14. Unplug the appliance from outlet when not in use, before putting on or taking off parts, before cleaning.

15. Make sure to place the plug all the way into socket when connecting your appliance.

16. Insert the plug into a single grounded socket.

17. Never use the appliance in place where combustible and inflammable materials are kept.

18. For safety reason, be sure to repair or replace parts at an authorized service dealers.

19. The motor is permanently lubricated and will require no oil.

20. The appliance must be positioned so that the plug is accessible.

21. Please according to local regulations regarding disposal of the appliance for its flammable blowing gas. Before you scrap the appliance, please take off the doors to prevent children trapped.

22. Ensure the refrigerator is unplugged before cleaning or if the product is not in use.

23. To clean the appliance use only mild detergents or glass cleaning products. Never use harsh detergents or solvents.

24. It is not recommended to use this refrigerator with an extension cord or power board. Please ensure that the appliance is plugged directly into the electrical outlet.

25. Do not place hot food or drink into the refrigerator before it cools down to room temperature.

26. Close the door immediately after putting in any items so the inside temperature will not rise dramatically.

27. Keep appliance away from any heat source or direct sunlight.

28. To fix stably, the appliance must be placed on a flat and solid surface. It should not be laid on any soft material.

29. Do not place any other appliance on top of the refrigerator, and do not wet it.

30. To avoid injury or death from electrical shock do not operate the appliance with wet hands, while standing on a wet surface or while standing in water.

31. Do not use outdoors or in wet conditions.

32. Never pull the cord to disconnect it from the outlet. Grasp the plug and pull it from the outlet.

33. Keep the cord away from heated surfaces.

34. Check that the voltage of the power supply in your home is the same as the voltage shown on the rating label of this product.

35. Connect your refrigerator to an independent electrical socket and use a safe ground wire.

36. When the frost in freezer is removed, or when there is no electricity or when refrigerator ceases to be used, it should be cleaned in order to prevent it from smelling.

37. Defrost the freezer at least once a month

because too much frost may affect refrigeration.

38. Turn on electricity only 5 minutes later after electricity goes off. Otherwise, the compressor may be damaged.

39. Children should be supervised to ensure that they do not play with the appliance.

40. The appliance is not intended to be operated by means of an external timer or a separate remote-control system.

41. This appliance has been incorporated with a grounded plug. Please ensure the wall outlet in your house is well earthed.

42. It is recommended to check regularly the supply cord for any sign of possible deterioration, and the appliance should not be used if the cable is damaged.

43. Regarding the information for replacing of the lamps of the appliance, thanks to refer to the paragraph "CLEANING AND CARE" of the manual.

44. Regarding the information pertaining to the installation, handing, maintenance, servicing and disposal of the appliance, thanks to refer to the paragraph "TRANSPORT AND HANDING" "INSTALLATION" "CLEANING AND CARE" "TROUBLESHOOTING" of the manual.

45. Disposal of the appliance: To prevent possible harm to the environment or human health from uncontrolled waste disposal, recycle it responsibly to promote the sustainable reuse of material resources. And the disposal should only be done through public collection points. Old refrigerators can contain CFC that destroy the ozone; contact the waste treatment center nearest your home for more details on the correct procedures for disposal

此标志需彩印，高度
至少15mm，其余黑白



46. **WARNING!** Risk of fire – flammable material. Please keep the product far away fire source during using, service and disposal. There are flammable materials at the back of the appliance.

CORRECT DISPOSAL OF THIS PRODUCT



This marking indicates that this product should not be disposed with other household wastes throughout the EU. To prevent possible harm to the environment or human health from uncontrolled waste disposal, recycle it responsibly to promote the sustainable reuse of material resources. To return your used device, please use the return and collection systems or contact the retailer where the product was purchased. They can take this product for environmental safe recycling.

We decline liability for any damage or accident derived from any use of this product which is not in conformity with the instructions contained in this booklet.

STRUCTURE ILLUSTRATION

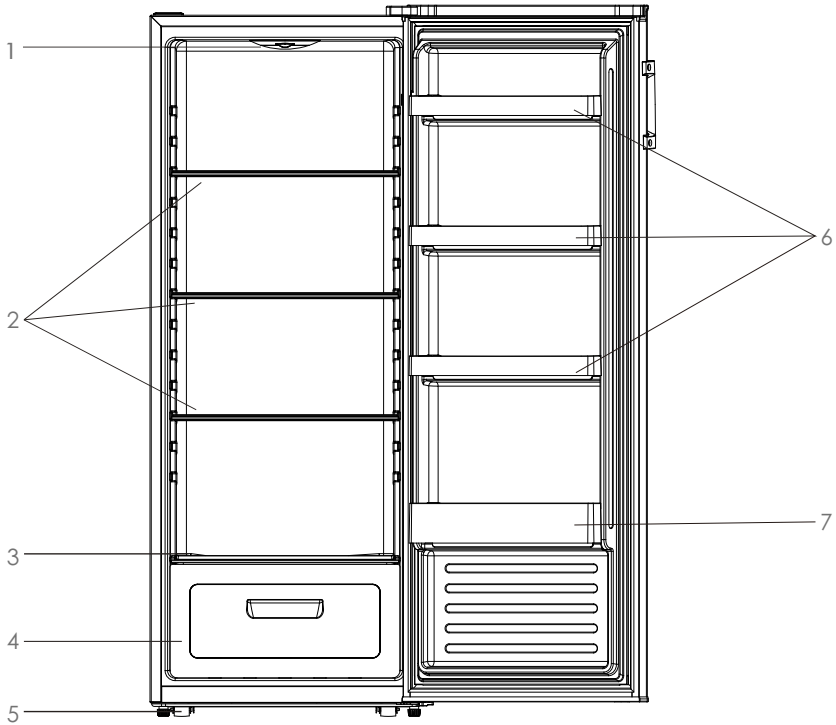

- 1. Thermostat Device
- 2. Glass Shelf
- 3. Salad Crisper Cover
- 4. Salad Crisper

- 5. Adjustable Foot
- 6. Full Balcony
- 7. Bottle balcony

Note: The glass shelves and the crisper can be removed and inserted for cleaning and storing of food according to the appliance.

TRANSPORT AND HANDING

When transportation, hold the base and lift the refrigerator carefully with an angle inferior at 45 degree. Never hold the door handle as support. Never place it upside down nor horizontally. Push refrigerator on its basis and place it thanks to its roller feet.

INSTALLATION

To fix stably, the appliance must be placed on a flat and solid surface. It should not be laid on any soft material.

Choose a location where there is no heat source. Keep the refrigerator away from direct sunlight or other appliance producing heat.

Choose a dry and well-ventilated place where there is no corrosive air.

In order to improve efficiency of the cooling system and save energy, it is necessary to maintain good ventilation around the appliance for the dissipation of heat. For this reason, sufficient clear space should be available around the refrigerator.

The appliance is supplied with two plastic spacers. After installation of these spacers, the appliance cannot be pushed against the wall to maintain proper ventilation. Insert the spacers into the relevant openings on the back of the appliance, then screw the spacers tightly. Place the appliance against a wall with a free distance that not exceeding 75 mm but more than 50mm.

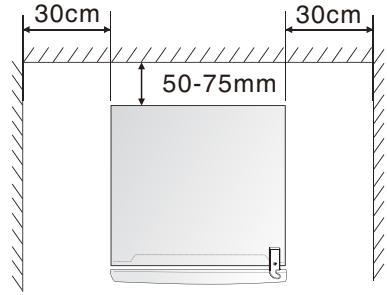
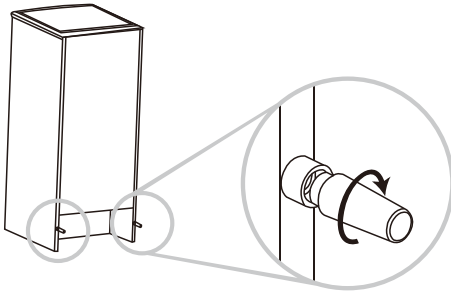

FIRST USE

Before the use of the refrigerator, remove all the packages, including bottom cushion and foam pads and rubber belts in the refrigerator.

Adjust the feet and clear the outside and inside of the refrigerator with warm cloth.

Do not start the refrigerator immediately after vertical placement. Only start it after 2-6 hours standing to ensure its proper operation.

To prevent damage to the power cord and any consequence incidents, the power cord should be not covered by the refrigerator or other objects. Before switching on the refrigerator, please check the voltage range of refrigerator carefully if the same as that of the power supply.

When the refrigerator is first installed, allow it stabilize at normal operating temperatures for 2-3 hours prior to filling it with fresh or frozen foods.

If operation is interrupted, wait for 5 minutes before restarting.

TEST

Clean the parts of the refrigerator with lukewarm water on a soft cloth or with a neutral detergent and with clear water, then wipe them dry.

Notes: Electric parts of the refrigerator can only be wiped by dry cloth.

Turn the thermostat knob on the "3" position and turn on electricity. The compressor and the light inside the refrigerator begin to work.

Close the door and wait 30 minutes. If the temperature in the freezer compartment decreased obviously, it shows that the refrigerator system works well. When the refrigerator operates for a period of time, the temperature controller will automatically set the temperature on conditions that the door is not too often opened.

If the above steps are successful, the trial operations are finished. The refrigerator works normally.

TEMPERATURE CONTROL

La température dans le réfrigérateur est contrôlée par le contrôleur de température installé sur la partie supérieure du compartiment du réfrigérateur.

Turn the thermostat knob to regulate the temperature inside the refrigerator.

The marks on the knob are not the exact number of the degrees of temperature but the temperature grades to "0" from "7". The first grade corresponds to a forced STOP of the refrigeration and the 7th grade corresponds to the lowest temperature the refrigerator can produce. Turn the knob from "1" position to "7" position, the temperature decreases continuously.

Set the thermostat knob to "3-4" position for a normal use.

STORAGE OF FOOD

Your appliance has the accessories as the “Structure illustration” showed in general, with this part instruction you can have the right way to storage your food. The glass shelves and crisper can be removed to store food if needed.

Note: Food is not allowed to touch directly all surfaces inside the appliance. It has to be wrapped separately in aluminum sheet or in cellophane sheet or in airtight plastic boxes.

Storing food in the refrigerator compartment

The fridge freezer compartment helps to extend the storage times of fresh perishable foods.

Fresh food care for best results:

- Store foods that are very fresh and of good quality.
- Ensure that food is well wrapped or covered before it is stored. This will prevent food from dehydrating, deteriorating in colour or losing taste and will help maintain freshness. It will also prevent odour transfer. Vegetables and fruit need not be wrapped if they are stored in the vegetable container of the fridge compartment.
- Make sure that strong smelling foods are wrapped or covered and stored away from foods such as butter, milk and cream which can be tainted by strong odours.
- Cool hot foods down before placing them in the fridge compartment.

Dairy foods and eggs

- Most pre-packed dairy foods have a recommended 'use by /best before/best by/ date stamped on them. Store them in the fridge compartment and use within the recommended time.
- Butter can become tainted by strong smelling foods so it is best stored in a sealed container.
- Eggs should be stored in the fridge compartment.

Red meat

- Place fresh red meat on a plate and loosely cover with waxed paper, plastic wrap or foil.
- Store cooked and raw meat on separate plates. This will prevent any juice lost from the raw meat from contaminating the cooked product.

Poultry

- Fresh whole birds should be rinsed inside and out with cold running water, dried and placed on a plate. Cover loosely with plastic wrap or foil.
- Poultry pieces should also be stored this way. Whole poultry should never be stuffed until just before cooking, otherwise food poisoning may result.

Fish and seafood

- Whole fish and fillets should be used on the day of purchase. Until required, refrigerate on a plate loosely covered with plastic wrap, waxed paper or foil.
- If storing overnight or longer, take particular care to select very fresh fish. Whole fish should be rinsed in cold water to remove loose scales and dirt and then patted dry with paper towels. Place whole fish or fillets in a sealed plastic bag.
- Keep shellfish chilled at all times. Use within 1-2 days.

Precooked foods and leftovers

- These should be stored in suitable covered containers so that the food will not dry out.
- Keep for only 1-2 days.
- Reheat leftovers only once and until steaming hot.

Vegetable container

- The vegetable container is the optimum storage location for fresh fruit and vegetables.
- Take care not to store the following at temperatures of less than 7°C for long periods: Citrus fruit, melons, aborigines, pineapple, papaya, cures, passion fruit, cucumber, peppers, tomatoes.
- Undesirable changes will occur at low temperatures such as softening of the flesh, browning and/or accelerated decaying.
- Do not refrigerate avocados (until they are ripe), bananas and mangoes.

DEFROSTING

Refrigerator compartment defrosts fully automatically

While the refrigerating unit is running, beads of condensation or hoarfrost form at the back of the refrigerator compartment. This is normal. It is not necessary to wipe off the condensation or frost. The rear panel defrosts automatically. The condensation runs into the condensation channel and is conveyed to the refrigerating unit where it evaporates.

Note: Keep the condensation channel and drainage hole clean, so that the condensation can run out.

HELPFUL HINTS AND TIPS

We recommend that you follow the tips below to save energy.

- Try to avoid keeping the door open for long periods in order to conserve energy.
- Ensure the appliance is away from any sources of heat(Direct sunlight, electric oven or cooker etc)
- Don't set the temperature colder than necessary.
- Don't store warm food or evaporating liquid in the appliance.
- Place the appliance in a well ventilated, humidity free room. Please refer to Installing your new appliance chapter.
- If the diagram shows the correct combination for the drawers, crisper and shelves, do not adjust the combination as this is designed to be the most energy efficient configuration.

Hints for fresh food refrigeration

- Do not place hot food directly into the refrigerator or freezer, the internal temperature will increase resulting in the compressor having to work harder and will consume more energy.
- Do cover or wrap the food, particularly if it has a strong flavor.
- Place food properly so that air can circulate freely around it.

Hints for refrigerator

- Meat (All Types) Wrap in polythene food: wrap and place on the glass shelf above the vegetable drawer. Always follow food storage times and use by dates suggested by manufacturers.

- Cooked food, cold dishes, etc.: They should be covered and may be placed on any shelf.
- Fruit and vegetables: They should be stored in the special drawer provided.
- Butter and cheese: Should be wrapped in airtight foil or plastic film wrap.
- Milk bottles: Should have a lid and be stored in the door racks.

Switching off your appliance

If the appliance needs to be switched off for an extended period, the following steps should be taken prevent mould on the appliance.

1. Remove all food;
2. Remove the power plug from the mains socket;
3. Clean and dry the interior thoroughly;
4. Ensure that all the doors are wedged open slightly to allow air to circulate.

CLEANING AND CARE

For hygienic reasons the appliance (including exterior and interior accessories) should be cleaned regularly at least every two months.

WARNING: The appliance must not be connected to the mains during cleaning. Danger of electrical shock! Before cleaning switch the appliance off and remove the plug from the mains socket.

Exterior cleaning

- To maintain good appearance of your appliance, you should clean it regularly.

- Wipe the digital panel and display panel with a clean, soft cloth.
- Spray water onto the cleaning cloth instead of spraying directly on the surface of the appliance. This helps ensure an even distribution of moisture to the surface.
- Clean the doors, handles and cabinet surfaces with a mild detergent and then wiped dry with a soft cloth.

Caution!

- Don't use sharp objects as they are likely to scratch the surface.
- Don't use Thinner, Car detergent, Clorox, ethereal oil, abrasive cleansers or organic solvent such as Benzene for cleaning. They may damage the surface of the appliance and may cause fire.

Interior cleaning

You should clean the appliance interior regularly. It will be easier to clean when food stocks are low. Wipe the inside of the fridge freezer with a weak solution of bicarbonate of soda, and then rinse with warm water using a wrung-out sponge or cloth. Wipe completely dry before replacing the shelves and baskets. Thoroughly dry all surfaces and removable parts.

Caution!

- Don't use sharp objects to remove frost from the freezer. Only after the interior completely dry should the appliance be switched back on and plugged back into the mains socket.

Door seals cleaning

Take care to keep door seals clean. Sticky food and drinks can cause seals to stick to the cabinet and tear when you open the door. Wash seal with a mild detergent and warm water. Rinse and dry it thoroughly after cleaning.

Caution!

- Only after the door seals are completely dry should the appliance be powered on.

Replacing the light bulb

If the internal light does not work anymore, please call the service after sale of the shop a retailer to replace the light bulb.

DOOR REVERSE

This fridge has been built with the door hinges on the right. If you want to change the opening direction, please follow the instruction below.

WARNING: When reversing the door, the appliance must not be connected to the mains. Remove the plug from the mains beforehand.

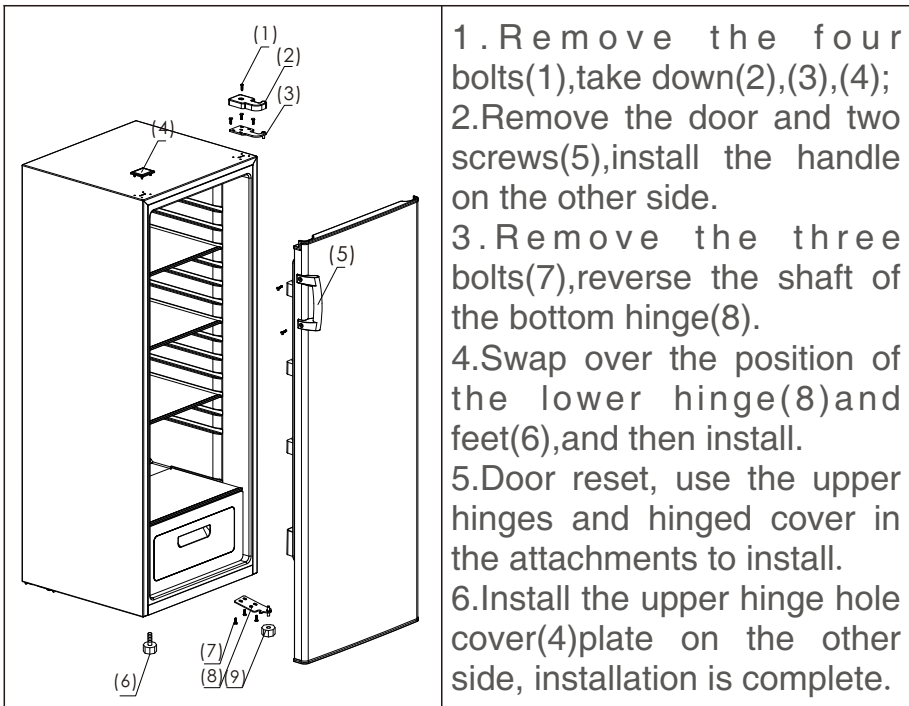

Installing the handles

This refrigerator has been built with external handles, which are in poly bag. Please follow instruction below to install them:

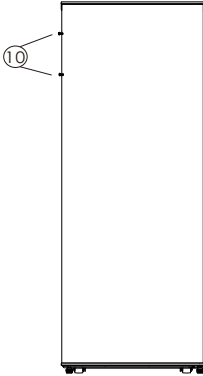

Figure 1

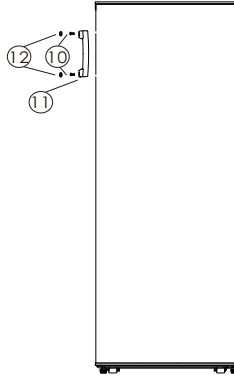

Figure 2

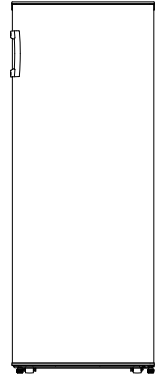

Figure 3

Figure 1: Front view without handles

Figure 2: Exploded view of installing the handles

Figure 3: Front view with handles

1. Remove two screws(10) by a cross screwdriver.
2. Take out the handles(11) and fix it with the two screws(10).
3. Cover the two screws(10) with two caps(12). The caps are in a small poly bag together with the handles.

COLDEST ZONE IN THE REFRIGERATOR

This symbol indicates the location of the coldest zone of the refrigerator, The area is bounded below by the glass crisper, and above by the symbol or the rack positioned at the same height.



To ensure the temperatures in this area, do not change the positioning of the shelf. In forced air refrigerators (equipped with a fan or No Frost models), the symbol of the coldest zone is not represented because the temperature inside is homogeneous.

Temperature indicator setting

To help you set your refrigerator well, it is equipped with a temperature indicator that will monitor the average temperature in the coldest zone.

WARNING: This indicator is intended to work only with your refrigerator, do not use it in another refrigerator (in fact, the coldest zone is not the same), or for any other use.

Checking the temperature in the coldest zone

With the temperature indicator, you can check regularly that the temperature of the coldest zone is correct. Indeed, the internal temperature of the refrigerator depends on several factors such as the ambient temperature of the room, the amount of food stored and the frequency of door opening. Take these factors into consideration when

setting the device.

When the indicator shows « OK », this means that your thermostat is well adjusted and the internal temperature correct.

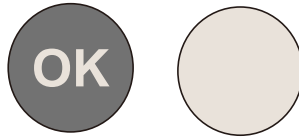

If the indicator of temperature turns WHITE, this means that the temperature is too high; in this case, increase the refrigerator temperature control setting and wait for 12 hours before performing a new visual inspection of the indicator.

When fresh food has been introduced or the door has been left open, it is possible for the indicator of temperature to turn WHITE after a while.

TROUBLESHOOTING

If your device shows the other symptoms that those described below, please call the service after sale of the shop a retailer.

Symptom	Cause	Solution
The appliance does not work	There is no power supply	Check the plug connecting it others appliance, or verify that the appliance is connected to the plug
	The fuse doesn't work	Replace the fuse
The appliance makes a lot of noise	The appliance is too close to the wall, or is not stable, or the accessories inside the refrigerator are placed in wrong position	Stabilize the base of the refrigerator by adjusting the position of feet, take away the device of the wall, place correctly the accessories inside the refrigerator
The appliance doesn't cool enough	The door is too often opened or was left opened for a long time	Close the door and do not open it too much frequently
	The refrigerator is too close to the wall	Take away the device of the wall to favor the ventilation
	The refrigerator is too full	Remove food of the device

Symptom	Cause	Solution
The appliance doesn't cool enough	The temperature is badly adjusted	Turn the knob of regulation of temperature on "3" or more
There are smells in the appliance	Food made obsolete inside the refrigerator	Throw away obsolete food and wrap the other
	The inside of the device at need to be cleaned	Clean the inside of the refrigerator

The following symptoms are not breakdowns:

- The noise of the cooling liquid which circulates in pipes can be heard, it is normal.
- The humidity on the surface outside of the device during the wet seasons is not a problem of the device; you just need to wipe it with a dry soft cloth.
- The compressor and the condenser can warm more during the periods of strong heat.
- The frame of the door is a bit hot; it means that the condenser works to evacuate the humidity of air.

TECHNICAL SPECIFICATIONS

Commercial reference :	REF1P AFM2204A+BK 4894223221030
Household refrigerating appliance model category	Refrigerator with one or more fresh-food storage compartments
Energy efficiency class	A+
<i>A+++ (the highest energy efficiency) to D (the lowest efficiency)</i>	
Annual energy consumption (AEc)	128 kWh/an
<i>Energy consumption of 128 kWh per year, calculated based on the result obtained for 24 hours under standardized test conditions. The actual energy consumption depends on the conditions of use and location of the device.</i>	
Total useful volume	238
- of which compartment for highly perishable goods (l)	
- of which storage compartment of fresh food (l)	238
- of which the wine storage compartment (l)	
- of which cellar compartment (l)	
- of which frozen food storage compartment (l)	
Number of stars:	NA
Lowest temperature of the wine storage compartment	NA
Frost-free	No
Autonomy	NA
Freezing capacity	NA
	N-ST
Climatic class	This appliance is designed to be used at an ambient temperature between +16°C and +38°C
Noise level	42 dB(A) re 1 Pw
Built-in appliance	No
Product dimensions (H x W x D)	1430 x 545 x 560 mm
Installation space (H X W x D)	1490 x 1158 x 935 mm
Rated voltage	220-240V~
Rated current	0.45A
Rated frequency	50Hz
Lamp power	MAX 10W
Protection against electrical shock	I

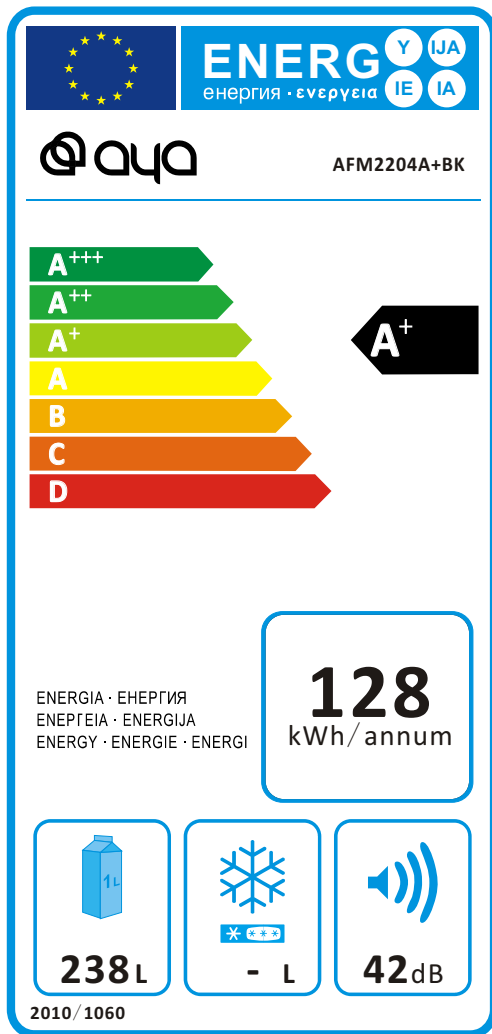

Notes: 128 kWh per year, based on the results of standard tests tested over a 24-hour period. The actual energy consumption will depend on the mode of use and location of the device.



Tous les papiers
se trient et se recyclent.

BUT INTERNATIONAL
1 Avenue Spinoza
77184 Emerainville, France