

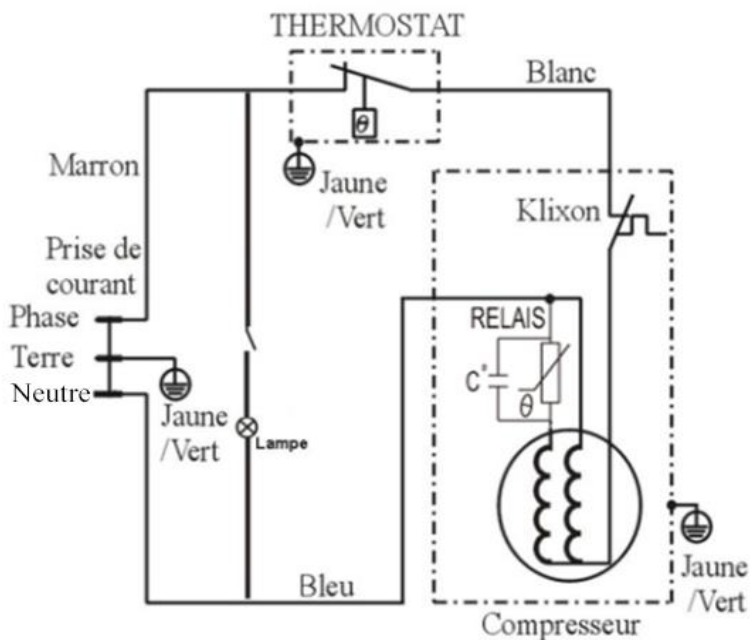

## Diagramme des circuits



## REFRIGERATEUR 2 PORTES

REFERENCE:	AFD210S
TENSION NOMINALE:	220-240V~
FREQUENCE NOMINALE:	50Hz
CONSOMMATION ENERGETIQUE E16:	0.360kWh/24h
CONSOMMATION ENERGETIQUE E32:	0.910kWh/24h
CONSOMMATION ENERGETIQUE ANNUELLE:	232kWh/an
COURANT NOMINAL:	1.0A
VOLUME UTILE:	208L
VOLUME REFRIGERATEUR:	160L
VOLUME CONGELATEUR:	48L
CLASSE CLIMATIQUE	N, ST
GAZ REFRIGERANT	R600a(51g)
CLASSE DE PROTECTION CONTRE CHOC ELECTRIQUE	CLASSE I
POIDS NET:	35kg
MOUSSE D'ISOLATION:	CYCLOPENTANE
POUVOIR DE CONGELATION:	2.5Kg/24h
AUTONOMIE EN CAS DE COUPURE	21h
NO.DE SERIE:	WWYY00001

BUT INTERNATIONAL

1, AVENUE SPINOZA

77184 EMERAINVILLE, France

FABRIQUE EN RPC

