

130±1

85±1

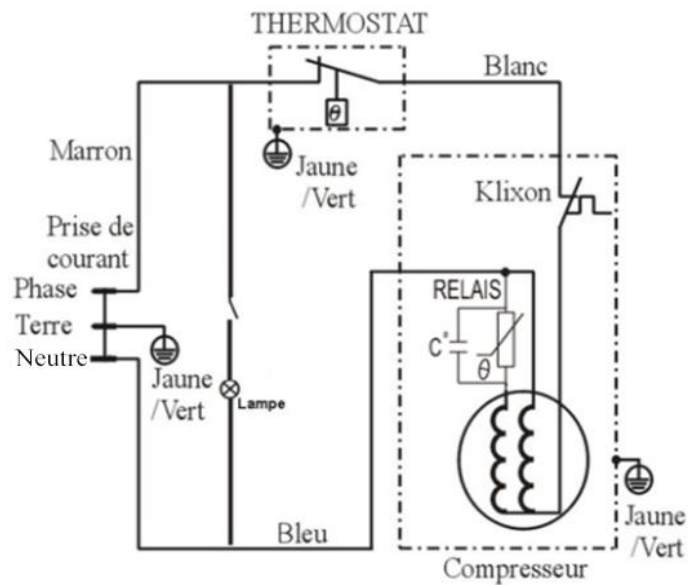

### Diagramme des circuits



### REFRIGERATEUR 2 PORTES

REFERENCE:	AFD1503A+X
TENSION NOMINALE:	220-240V~
FREQUENCE NOMINALE:	50Hz
CONSOMMATION ENERGETIQUE	0.483kWh/24h
COURANT NOMINAL:	1.0A
PUISSANCE DE LA LAMPE:	10W
VOLUME UTILE:	136L
CLASSE CLIMATIQUE	N, ST
GAZ REFRIGERANT	R600a(40g)
CLASSE DE PROTECTION CONTRE CHOC ELECTRIQUE	CLASSE I
POIDS NET:	27kg
MOUSSE D'ISOLATION:	CYCLOPENTANE
POUVOIR DE CONGELATION:	2.0Kg/24h
AUTONOMIE EN CAS DE COUPURE	21.4h
NO.DE SERIE:	WWYY00001

BUT INTERNATIONAL  
1, AVENUE SPINOZA  
77184 EMERAINVILLE, France  
FABRIQUE EN RPC



85±1

90±1