

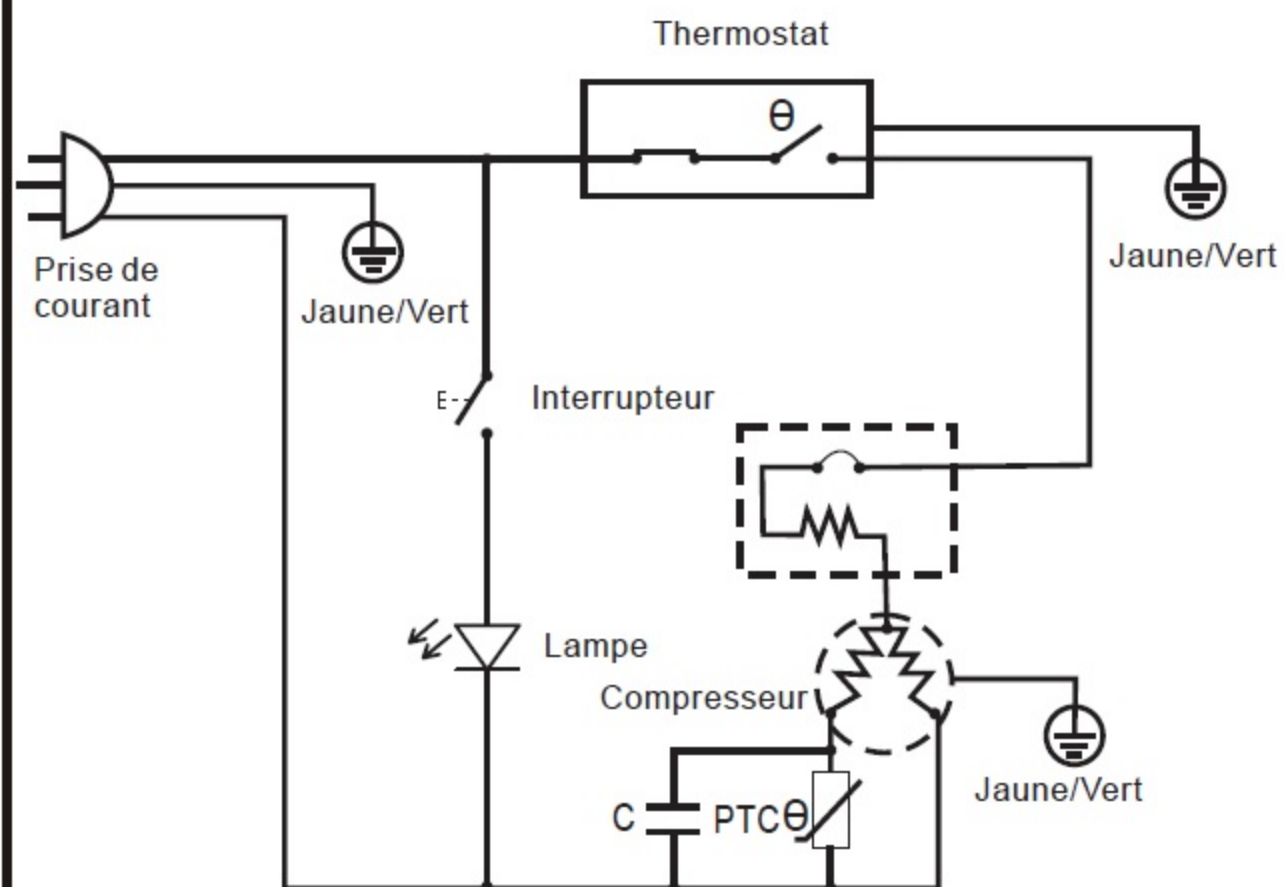

REFRIGERATEUR-CONGELATEUR



REFERENCE:	AFD132W
TENSION NOMINALE:	220-240V~
COURANT NOMINAL:	0.7A
FREQUENCE NOMINALE:	50Hz
PUISSANCE DE LA LAMPE:	1W
VOLUME UTILE TOTAL:	132L
VOLUME UTILE DU REFRIGERATEUR:	98L
VOLUME UTILE DU CONGELATEUR:	34L
CLASSE CLIMATIQUE:	N/ST
GAZ REFRIGERANT:	R600a(40g)
CONSOMMATION D'ENERGIE:	0.570kWh/24h
CONSOMMATION D'ENERGIE ANNUELLE:	208kWh/a
AUTONOMIE:	7.5h
POUVOIR DE CONGELATION:	2.0kg/24h
CLASSE DE PROTECTION CONTRE CHOC ELECTRIQUE:	I
POIDS NET:	28kg
MOUSSE D'ISOLATION:	CYCLOPENTANE
CLASSE ENERGETIQUE:	F
NO. DE SERIE:	012200001

BUT INTERNATIONAL
1, AVENUE SPINOZA
77184 EMERAINVILLE, FRANCE
FABRIQUE EN RPC

