

120

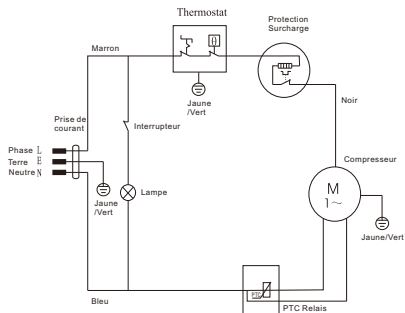

# REFRIGERATEUR



REFERENCE:	AFC2500A+
TENSION NOMINALE:	220-240V~
COURANT NOMINAL:	1.2A
FREQUENCE NOMINALE:	50Hz
PUISSANCE DE LA LAMPE:	MAX 10W
VOLUME TOTAL:	235L
CLASSE CLIMATIQUE:	N/ST
GAZ REFRIGERANT:	R600a(70g)
CONSUMMATION ENERGETIQUE:	0.61kWh/24h
CLASSE DE PROTECTION CONTRE CHOC ELECTRIQUE:	I
POIDS NET:	45.5kg
MOUSSE D'ISOLATION:	CYCLOPENTANE
CLASSE ENERGETIQUE:	A+
NO. DE SERIE:	WWYY00001

BUT INTERNATIONAL  
1, AVENUE SPINOZA  
77184 EMERAINVILLE, FRANCE  
FABRIQUE EN RPC



80