

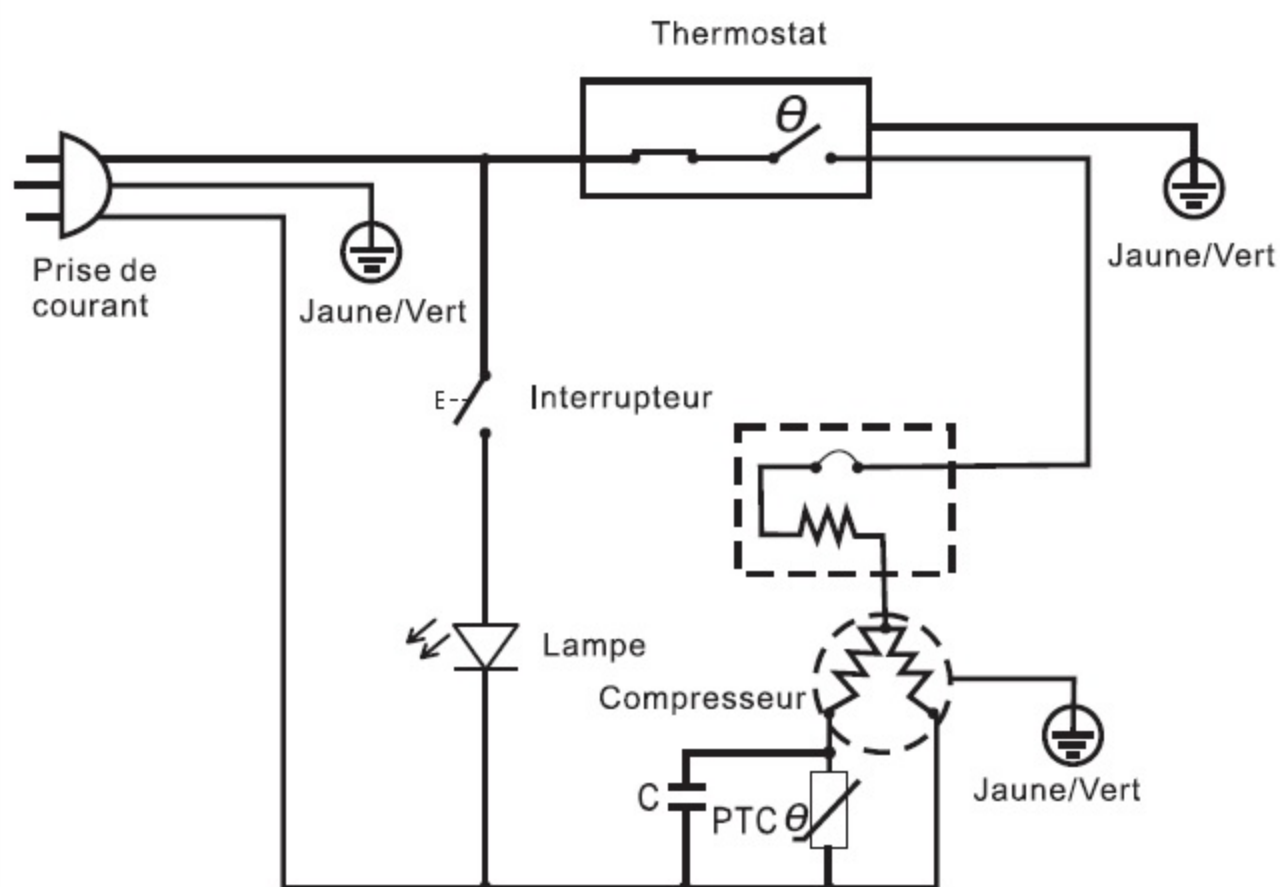

REFRIGERATEUR-CONGELATEUR



REFERENCE:	AFC1540W
TENSION NOMINALE:	220-240V~
COURANT NOMINAL:	0.7A
FREQUENCE NOMINALE:	50Hz
PUISSANCE DE LA LAMPE:	1W
VOLUME UTILE TOTAL:	154L
VOLUME UTILE DU REFRIGERATEUR:	120L
VOLUME UTILE DU CONGELATEUR:	34L
CLASSE CLIMATIQUE:	N/ST
GAZ REFRIGERANT:	R600a(51g)
CONSOMMATION D'ENERGIE DE E32:	0.644kWh/24h
CONSOMMATION D'ENERGIE ANNUELLE:	168kWh/a
AUTONOMIE:	8.0h
POUVOIR DE CONGELATION:	2.0kg/24h
CLASSE DE PROTECTION CONTRE CHOC ELECTRIQUE:	I
POIDS NET:	35kg
MOUSSE D'ISOLATION:	CYCLOPENTANE
CLASSE ENERGETIQUE:	E
NO. DE SERIE:	182300141

BUT INTERNATIONAL
1, AVENUE SPINOZA
77184 EMERAINVILLE, FRANCE
FABRIQUE EN RPC



182300141