

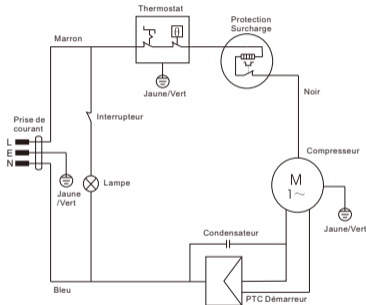

REFRIGERATEUR-CONGELATEUR



REFERENCE:	AFC2003W
TENSION NOMINALE:	220-240V~
COURANT NOMINAL:	0.6A
FREQUENCE NOMINALE:	50Hz
PUISSANCE DE LA LAMPE:	MAX 10W
VOLUME UTILE TOTAL:	146L
VOLUME UTILE DU REFRIGERATEUR:	91L
VOLUME UTILE DU CONGELATEUR:	55L
CLASSE CLIMATIQUE:	N/ST
GAZ REFRIGERANT:	R600a(46g)
CONSOMMATION D'ENERGIE DE E16:	0.349kWh/24h
CONSOMMATION D'ENERGIE DE E32:	0.937kWh/24h
CONSOMMATION D'ENERGIE ANNUELLE:	235kWh/a
AUTONOMIE:	12h
POUVOIR DE CONGELATION:	2.5kg/24h
CLASSE DE PROTECTION CONTRE CHOC ELECTRIQUE:	I
POIDS NET:	39kg
MOUSSE D'ISOLATION:	CYCLOPENTANE
CLASSE ENERGETIQUE:	F
NO. DE SERIE:	WWYY00001

BUT INTERNATIONAL
1, AVENUE SPINOZA
77184 EMERAINVILLE, FRANCE
FABRIQUE EN RPC

