

120

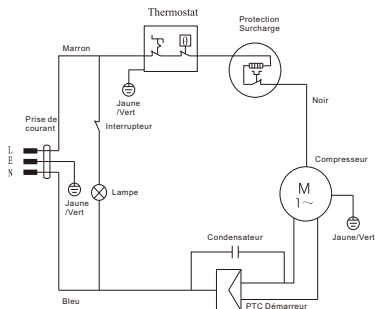

# REFRIGERATEUR



REFERENCE:	AFC2003A+
TENSION NOMINALE:	220-240V~
COURANT NOMINAL:	0.6A
FREQUENCE NOMINALE:	50Hz
PUISSANCE DE LA LAMPE:	MAX 10W
VOLUME TOTAL:	151L
CLASSE CLIMATIQUE:	N/ST
GAZ REFRIGERANT:	R600a(52g)
CONSOMMATION ENERGETIQUE:	0.56kWh/24h
CLASSE DE PROTECTION CONTRE CHOC ELECTRIQUE:	I
POIDS NET:	41kg
MOUSSE D'ISOLATION:	CYCLOPENTANE
CLASSE ENERGETIQUE:	A+
NO. DE SERIE:	WWYY00001

80

BUT INTERNATIONAL  
1, AVENUE SPINOZA  
77184 EMERAINVILLE, FRANCE  
FABRIQUE EN RPC