

120

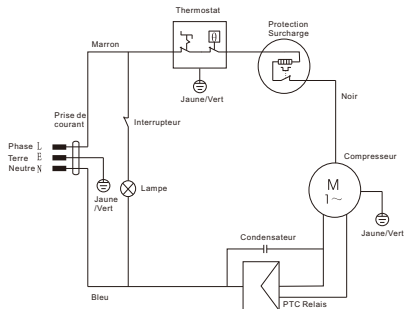

REFRIGERATEUR



REFERENCE: AFC2002A+
TENSION NOMINALE: 220-240V~
COURANT NOMINAL: 0.6A
FREQUENCE NOMINALE: 50Hz
PUISSANCE DE LA LAMPE: 10W
VOLUME TOTAL: 146L
CLASSE CLIMATIQUE: N/ST/T
GAZ REFRIGERANT: R600a(46g)
CONSOMMATION ENERGETIQUE: 0.52kWh/24h
CLASSE DE PROTECTION CONTRE CHOC ELECTRIQUE: I
MOUSSE D'ISOLATION: CYCLOPENTANE
CLASSE ENERGETIQUE: A+
NO. DE SERIE: WWYY00001

80

BUT INTERNATIONAL
1, AVENUE SPINOZA
77184 EMERAINVILLE, FRANCE
FABRIQUE EN CHINE

