



Better than you ever imagined

Installation Instructions for Rayburn Heatranger 355M Solid Fuel and Wood Burning Cooker

Consumer Protection Act 1987

As responsible manufacturers we take care to make sure that our products are designed and constructed to meet the required safety standards when properly installed and used.

IMPORTANT NOTICE: PLEASE READ THE ACCOMPANYING WARRANTY.

Any alteration that is not approved by Aga, could invalidate the approval of the appliance, operation of the warranty and could also affect your statutory rights.

Control of Substances - Health and Safety Important

This appliance may contain some of the materials that are indicated. It is the Users/Installers responsibility to ensure that the necessary personal protective clothing is worn when handling, where

IMPORTANT NOTICE: Any alteration that is not approved by Aga, could invalidate the approval of the appliance, operation of the warranty and could also affect your statutory rights.

Control of Substances - Health and Safety Important

This appliance may contain some of the materials that are indicated. It is the Users/Installers responsibility to ensure that the necessary personal protective clothing is worn when handling,

applicable, the pertinent parts that contain any of the listed materials that could be interpreted as being injurious to health and safety, see below for information.

Firebricks, Fuel beds, Artificial Fuels - when handling use disposable gloves.

Fire Cement - when handling use disposable gloves.

Glues and Sealants - exercise caution - if these are still in liquid form use face mask and disposable gloves.

Glass Yarn, Mineral Wool, Insulation Pads, Ceramic Fibre, Kerosene Oil - may be harmful if inhaled, may be irritating to skin, eyes, nose and throat. When handling avoid inhaling and contact with skin or eyes. Use disposable gloves, face-masks and eye protection. After handling wash hands and other exposed parts. When disposing of the product, reduce dust with water spray, ensure that parts are securely wrapped.

PERFORMANCE

The Rayburn 355M is intended to supply heating for:-

- (a) Cooking and domestic hot water.
- (b) Cooking, domestic hot water and central heating.

Air for combustion within the firebox is obtained from two sources viz:-

- a) When the appliance is being used for cooking and domestic hot water only, the rate of burning is determined by the manually operated spinwheel control on the ashpit door.
- b) When central heating is also required, close the spinwheel control and operate the burning rate by means of the boiler thermostat.

The cooker has both boiler and cooker flues which are opened/closed by internal dampers working in conjunction and operated manually by the cooker/boiler damper at the front of the cooker.

The setting should be relative to the services required, viz:- **H** for all services, **C** for cooking and domestic hot water only.

REMEMBER, when replacing a part on this appliance, use only spare parts that you can be assured conform to the safety and performance specification that we require. Do not use reconditioned or copy parts that have not been clearly authorised by AGA

WARNING

THE ASHPIT AND FIREBOX DOORS MUST BE LOCKED CLOSED AT ALL TIMES DURING NORMAL USE, EXCEPT WHEN LIGHTING OR RE-FUELLING.

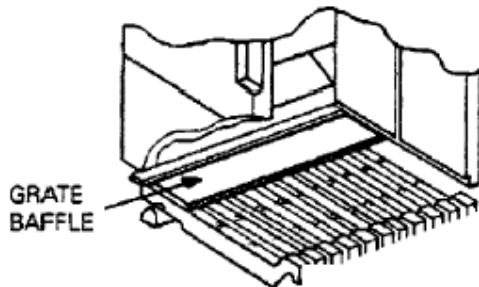

DESN510291

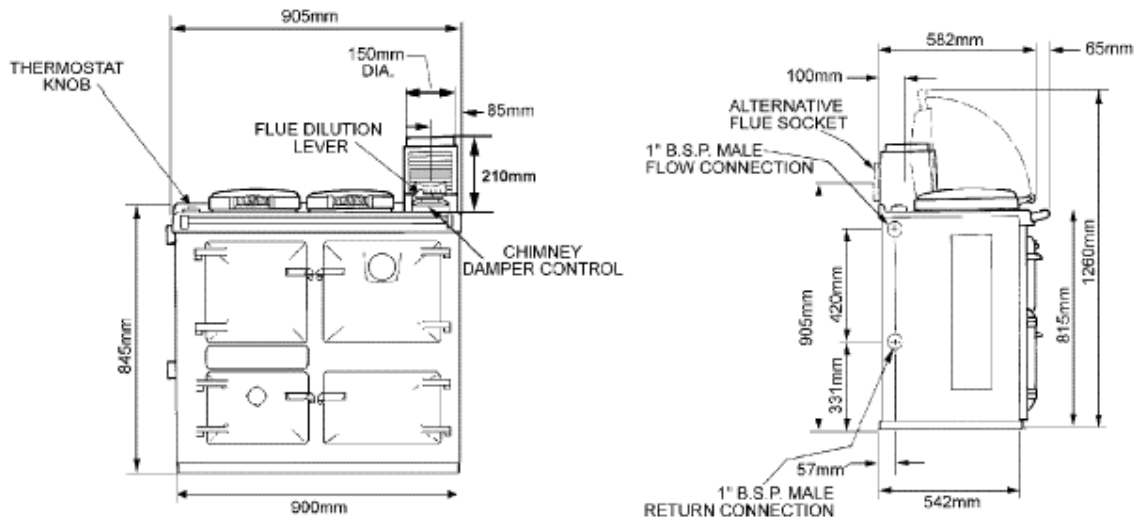

DESN510278B

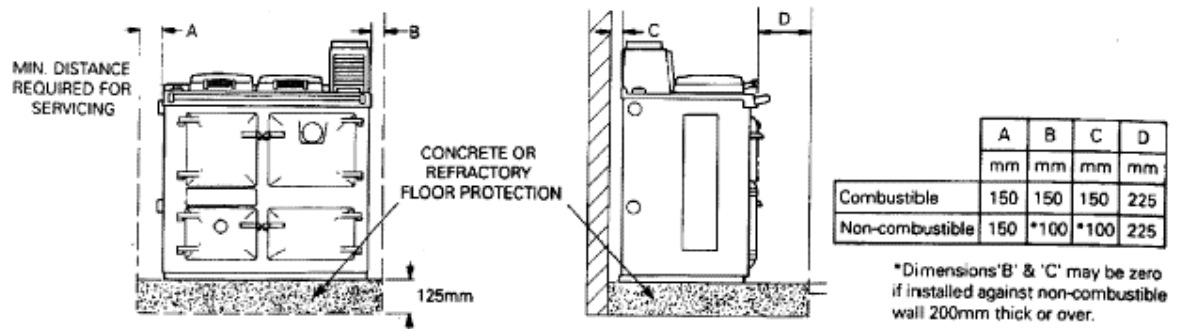

Fig.1 DESN 510279B

RATINGS - Burning Solid Fuel

Winter Use (See Para. re: [Firebrick Positions](#)) The maximum boiler output obtainable burning solid fuel at the optimum burning rate - with the cooker/boiler damper knob at **H** and the boiler thermostat at No.8 - is 16.12kW (55,000 Btu/h). This will provide for 29.89m of radiator surface and pipework plus domestic hot water or 32.24m of radiator surface and pipework only. The recommended heating surfaces indicated are based on an average heat emission of 0.5kW/m (160 Btu/h/ft). When cooking only, with the cooker/boiler damper knob at **C** and oven at a steady 230°C (450°F), the water output reduces to 5.6kW (19,000 Btu/h). Overnight banking with the cooker/boiler damper knob at **C** will produce 2.3kW (8,000 Btu/h) of hot water from the boiler.

Summer Use See para re: [Firebrick Positions](#)

With the cooker/boiler damper knob at **C** and the oven temperature maintained at a steady 200°C (390°F) the hot water output from the boiler will be 3.1kW (10,500 Btu/h). Overnight banking with the cooker/boiler damper knob at **C** will produce 1.9kW (6,900 Btu/h) of hot water from the boiler.

RATINGS - Burning Wood

Winter Use: To obtain the optimum burning rate with the wood burning fuels only, a grate baffle should be located on the top face of the reciprocating bars, at the rear of the firebox. [See diagram.](#)

Grate riddling is not required when burning wood where poking will normally suffice.

Always remove this grate baffle when burning solid fuels.

See para. re: [Firebrick Positions](#)

The maximum boiler output obtainable burning wood logs at the optimum burning rate - with the cooker/boiler damper knob at **H** and the boiler thermostat at No.8 - is 10.26kW (35,000 Btu/h). This will provide for 18.17m²(194ft²) of radiator surface and pipework plus domestic hot water 20.52m²(219ft²) of radiator surface and pipework only. Overnight banking with the cooker/boiler damper knob at **C** will produce 1.46kW (5,000 Btu/h) of hot water from the boiler.

Summer Use See para. re: [Firebrick Positions](#)

With the cooker/boiler damper knob at **C** and the oven maintained at roasting temperature the hot water output from the boiler will be 2.6kW (9,000 Btu/h) of hot water from the boiler.

Overnight banking with the cooker/boiler damper knob at **C** will produce 1.46kW (5,000 Btu/h) of hot water from the boiler.

PREPARATION OF SITE

The non-combustible hearth must be solid and level and together with the walls adjacent to the cooker and chimney, conform to current Building Regulations.

The cooker and chimney flue installation should be in accordance with the relevant recommendations of the British Codes of Practice BS 8303, BS 6461 Part 1 and BS 7566 Parts 1 to 4 respectively and the central heating system to BS 5449 Part 1. The boiler installation section must also be in accordance with the byelaws of the local Water Undertaking, Regulations for the Electrical Equipment of Buildings -published by the Institute of Electrical Engineers and any relevant requirements of the Local Authority.

Ensure that any electrical wiring is correctly earthed.

COOKER POSITION

When the cooker is installed in a recess it must be 'freestanding' and not built-in solid at the sides. Ensure that any combustible material e.g. kitchen furniture is spaced away from the cooker to the recommended distances. See [Fig. 1.](#)

Tiling

Where the cooker is to stand in a recess or against a wall which is to be tiled, **in no circumstances should the tiles overlap the cooker top plate.**

BUILDERS OPENING

From 200mm thick non-combustible or new recesses, an opening of 1,080mm wide minimum, by 343mm deep minimum and 1,680mm high minimum from floor is recommended.

NOTE (SEE FIG. 1): PLEASE NOTE IT IS ADVISABLE TO CHECK THE SIZE/WIDTH OF YOUR APPLIANCE BEFORE FINALLY FIXING ANY KITCHEN UNITS SINCE ENAMELLED CAST IRON CAN VARY IN SIZE.

THE CHIMNEY

Checking existing chimney

The internal and external condition of the chimney should be checked **before** the appliance is installed and rectification made where necessary to prevent leakage or porosity. The soundness of the chimney which should have a minimum flue dimension of 175mm square or 185mm diameter can be confirmed by smoke testing. Advice on the test method can be obtained from HETAS.

When repairing or re-using chimneys its recommended that the building control office be consulted before the commencement of work with particular attention to the chimney height and its termination.

The chimney must be swept before installation.

Erecting New Chimney

The flue through the chimney should be formed with pre-cast moisture and acid-resistant liners with a minimum internal dimension of 185mm square and all in accordance with the current Building Regulations (England and Wales) and in Scotland the Building Standards (Scotland) (Consolidation) Regulations and the Codes of Practice for chimneys and flues BS. 6461 Part 1 and BS 7566 Parts 1 to 4.

Ensure the chimney liners are free of projecting internal building jointing composition before the appliance is installed.

Factory made Insulated Chimneys

It is recommended the chimney be ceramic lined and comply with BS. 4543.

The minimum diameter for a straight chimney is 175mm and if offsets are fitted the recommended minimum diameter is 200mm.

IN ALL TYPES OF CHIMNEYS THE MINIMUM HEIGHT FOR CORRECT OPERATION OF THE COOKER IS 5.5m AND SHOULD TERMINATE ABOVE THE ROOF IN ACCORDANCE WITH REGIONAL STATUTORY REQUIREMENTS.

RECOMMENDED FLUE DRAUGHT - 2mm W.G. (0.08in) MINIMUM. THE APPLIANCE SHOULD BE INSTALLED AND CONFORM TO THE CURRENT CODES OF PRACTICE FOR INSTALLATION OF DOMESTIC HEATING AND COOKING APPLIANCES BURNING SOLID FUEL - BS 8303.

ALWAYS ADVISE THE USER TO CLEAN THE COOKER FLUES IN ACCORDANCE WITH THE OPERATING INSTRUCTIONS AND TO HAVE THE CHIMNEY SWEEPED AT A MINIMUM OF 12 MONTHLY INTERVALS AFTER THE COOKER IS COMMISSIONED.

WARNING: PROLONGED SOOT FORMATION MAY RESULT IN THE FLUEWAYS BECOMING BLOCKED AND COULD GIVE RISE TO THE RELEASE OF CARBON MONOXIDE, A POISONOUS GAS INTO THE ROOM.

COOKER FLUE CONNECTION

The position of available types of flue layouts are shown in [Figs. 2, 3](#) and [4](#), the cooker flue chamber is adaptable to provide either top or back flue outlets, by means of the reversible loose socket.

(a) Rear Flue Outlet

This must only be used where there is a brick flue immediately behind the cooker. Provision must be made for a condensate collecting vessel and cleaning door. See [Fig. 3](#).

NOTE: EXTENDED REAR FLUE PIPE AND BENDS ARE NOT RECOMMENDED.

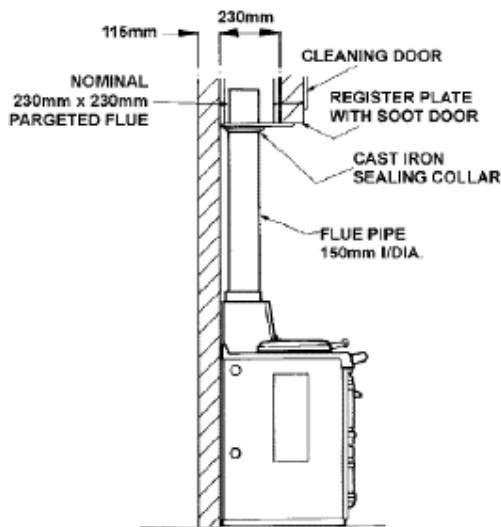

Fig. 2 DESN510281B

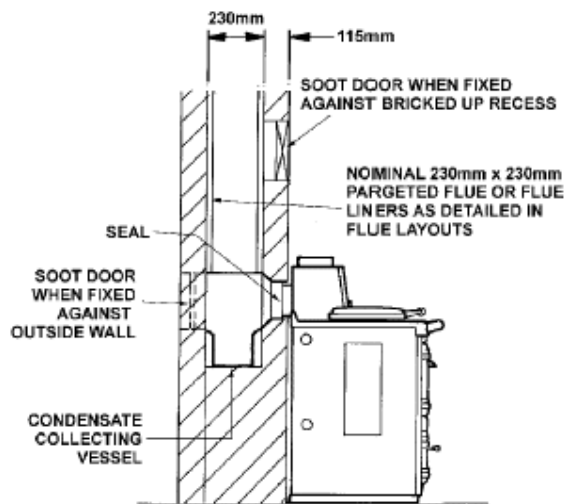

Fig. 3 DESN510282B

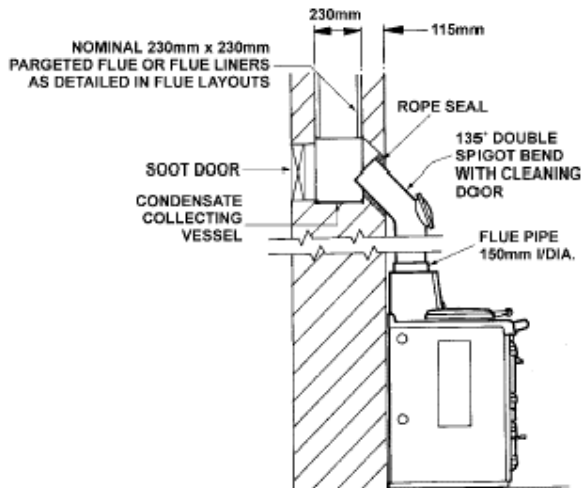

Fig. 4 DESN510283B

(b)Top Flue Outlet

The cooker should be connected to the main flue via a 150mm minimum diameter cast iron pipe or appropriately internally externally vitreous enamelled mild steel pipe and be sealed to the cooker flue chamber with soft rope and fire cement.

Any bends in the flue pipe must be not less than 135° (45° from horizontal) and be complete with a cleaning door.

FLUE LAYOUTS

In [Fig. 2](#), the cooker is installed in an existing recess. There must be a clearance of not less than 150mm between the top of the flue pipe and any overhanging brickwork.

Any cavities or pockets above the register plate should as far as possible be filled and if necessary the flue pipe should be extended into the throat of the chimney and soot door provided for chimney sweeping.

If a flue liner or insulated chimney is used, the size should not be less than 185mm square or 225mm diameter, and 175mm diameter respectively.

In [Fig. 3](#), the cooker is connected direct to a brick flue.

Horizontal pipe runs between cooker and brick flue **must not** be used.

In [Fig. 4](#), the cooker is connected to an existing brick flue with a length of flue pipe. Square bends and horizontal runs **must not** be used. There must be a cleaning door at every bend.

NOTE: WHATEVER METHOD OF INSTALLATION IS EMPLOYED, AIR MUST NOT BE ALLOWED TO ENTER THE CHIMNEY EXCEPT THROUGH THE COOKER. ALL JOINTS MUST BE AIR-TIGHT.

If the chimney is unlined, and there is any doubt about its condition, it should be lined in accordance with current Building Regulations.

PROVISION MUST ALWAYS BE MADE FOR SWEEPING THE CHIMNEY.

IMPORTANT: CEMENT TYPE PIPES AND FITTINGS MUST NOT BE USED WITHIN 2m. OF COOKER. CHIMNEYS OF PLAIN PIPE ARE NOT RECOMMENDED BUT CERTAIN PROPRIETARY MAKES OF INSULATED CHIMNEY ARE SUITABLE.

AIR SUPPLY

Provision must be made for a permanent unobstructed air vent having a minimum effective area of 182.5cm² (28.25sq in) communicated directly to outside air or an adjacent room which itself has a permanent air vent of at least the flue size direct to outside air.

Effect of Extractor Fan

Avoid if possible the installation of extractor fan in the same room as the cooker. Compensating extra air inlets must be introduced equivalent to the capacity of the fan when fitted.

CENTRAL HEATING AND HOT WATER SYSTEM

It is recommended that a 190 litre (40 galls) indirect hot water storage cylinder of the double feed type e.g. (Manufactured by Albion Cylinders, complying with BS. 1566 Part 1:DF Type 10) should be lagged and fixed vertically as near as possible to the cooker.

The 28mm minimum diameter primary flow and return pipes must not exceed 10m in length and pipes longer than 5m must be lagged.

Ensure that the flow pipe has an open vent and rises continuously from the boiler to the cylinder to ensure good gravity circulation.

In combined systems, the water draw-off pipes to the taps must be dead-leg connection from the vent/expansion pipe.

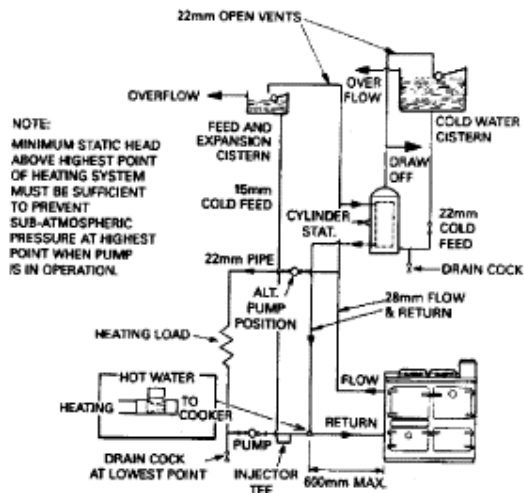

Fig. 5 DESN 510284'A' Typical Central Heating/Hot Water System

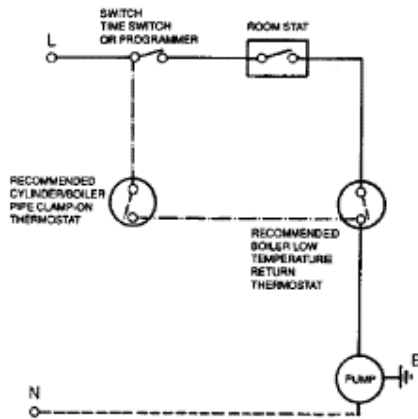

Fig.6 DESN 510285 Typical Wiring Diagram

There are only two boiler tappings on this cooker and a typical design layout is shown in [Fig. 5](#).

An injector tee is provided which must be fitted to ensure adequate primary flow circulation when the water circulator is operating, otherwise there may be a lack of domestic hot water. The heating flow and return pipes may be 22mm, the return pipe being connected to the 28mm primary return by the injector tee, and the tee outlet connected to the boiler return pipe.

All installations must be fitted with a drain tap at the lowest point of the system.

BOILER - Control

In order to maximise the life of your boiler body, an electrical thermal re-set low temperature boiler thermostat has been fitted within the appliance, behind the LH side removable cover, whose purpose is to isolate the electrical power from the water circulator when the boiler thermostat falls below 60°C (140°F) and thus minimise harmful condensation on the boiler surfaces. The 3 core 0.75mm² cable lead from the appliance must be connected to/from the water circulator as indicated on the 'Typical Wiring Diagram' in [Fig. 6](#).

NOTE: IF THERE IS A POSSIBILITY OF BOILING TAKING PLACE A REVERSE ACTING THERMOSTAT SHOULD BE FITTED TO THE DOMESTIC HOT WATER CYLINDER OR BOILER PRIMARY FLOW PIPES, AND ELECTRICALLY CONNECTED TO THE CENTRAL HEATING PUMP, THIS WILL SWITCH THE PUMP 'ON' TO PREVENT BOILING.

HIGH UPDRAUGHTS

Tall chimneys may develop excessively high updraughts which prevent the appliance operating correctly.

It is recommended that a proprietary brand adjustable flue draught stabiliser having an openable cross sectional area of 182.5sq cm (28.25 sq in) be fitted above the flue pipe

connection, either in the brickwork or into a right angle 'T' fitting in the flue pipe position that will not inconvenience appliance operation or maintenance.

GENERAL - Firebrick Positions and Replacement

The Rayburn 355M is delivered complete including a set of boiler removable firebricks where positional location determines the amount of hot water supplied in winter and summer seasons.

The oven side and firebox front firebricks are permanently fixed with fire cement, whilst the two boiler face side bricks and boiler back brick are located for the summer season thereby providing domestic hot water only. For winter use or central heating facilities, the boiler face rear brick is removed and the boiler face side bricks are transferred to locate on/over the oven side firebricks. See [diagram 7](#).

The firebricks fitted to the Rayburn Cookers are of first quality manufacture, and providing the cooker has been installed and used correctly will have a reasonable life. There are, however, expendable items and in time will require renewal. The renewal of firebricks is not a major operation and can be carried out by the average handyman. Replacement bricks either in sets or singly can be obtained from your Rayburn Distributor. Quote the serial number which will be found on the fire door dataplate

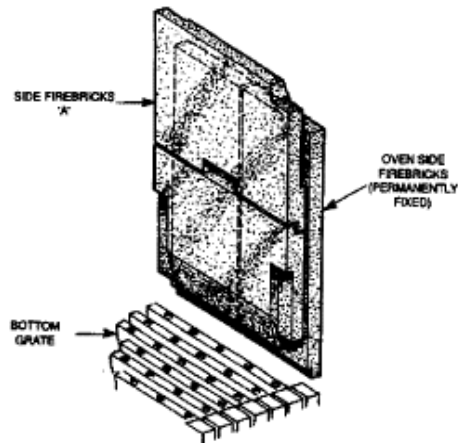

Fig. 7 DESN 510286

WINTER USE (DOMESTIC HOT WATER & CENTRAL HEATING) SIDE FIREBRICKS 'A' MOUNTED IN RIGHT HAND SIDE OF FIREBOX OVER PERMANENTLY FIXED OVEN SIDE FIREBRICKS & REAR FIREBRICK 'B' REMOVED.

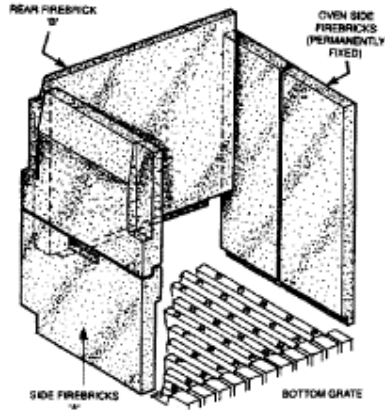

Fig. 7 DESN 510287

SUMMER USE (DOMESTIC HOT WATER ONLY) SIDE FIREBRICKS 'A' MOUNTED IN LEFT HAND SIDE OF FIREBOX & REAR FIREBRICK 'B' IN POSITION.

INSTALLATION

Place the cooker in the intended position and lift out of the surface ground hotplate, checking that the joint between the underside of the hob and the top of the cooker are intact.

Any joints which have opened should be made good with fire cement provided.

Check that the boiler/cooker flueway dampers operate correctly by turning the knob on the front plate adjacent to the top left hand corner of the roasting oven door.

NOTE: IT IS NOT VISUALLY POSSIBLE TO SEE THE BOILER DAMPER AND THIS SHOULD BE CHECKED BY FEELING THROUGH THE HOTPLATE APERTURE TO THE BACK OF THE COOKER. THE COOKER DAMPER SPINDLE OPERATES THE BOILER DAMPER WHICH CAN BE FELT BY INSERTING HAND INTO FLUEWAY.

Replace the hotplate making sure that it is seating evenly on the soft rope and that it is approximately 1.5mm proud of the enamelled top plate, with an equal space all round.

1. Connect pipework to boiler flow and return tappings.
2. Fit the Flue Chamber which should be given a 1mm smear of fire cement on the underside then screwed to the cooker. Make sure there is a good seal between the flue chamber and the cooker top (if there is an ingress of air it can affect the flue draught and proper working of the cooker). Before the fire cement hardens remove any surplus with a damp cloth then polish with a dry cloth. Failure to do so can result in the enamel surface being permanently marked.
3. Open the firebox and ashpit doors and check that the reciprocating bottomgrate bars are in position. Operate the riddling lever to ensure bottomgrate operation.
4. Turn the boiler thermostat knob at the rear left hand corner of the top plate from No.1 (low) to No.8 (high).

NOTE: THE HIGHER THE NUMBER, THE HIGHER THE WATER TEMPERATURE.

The handrail brackets are held on the front ends of the cooker top-plate casting. Remove the travel nuts and replace with the handrail brackets ensuring the fibre protecting washers are in position. Insert the handrails with fitted endcaps into the brackets, positioning them correctly, and tighten the locating bolts (Fig. 8).

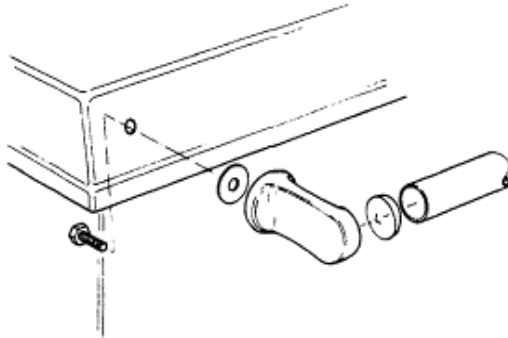

Fig.8 DESN 510454 A

TESTING AND COMMISSIONING

After completing the installation, the Heating Contractor should demonstrate to the user, the operation of the appliance and the routine cleaning method.

Check that the system is full of water and free from air locks.

When lighting pull the flue chamber damper open to maximum, add paper and sticks with a small quantity of fuel through fuelling aperture onto bottomgrate and close the firebox door.

Open ashpit door, ignite fuel and close ashpit door when fuel is well alight with boiler thermostat knob or spinwheel on ashpit door at required setting.

Allow the cooker to heat up gradually at first time lighting.

NOTE: SMOKE/SMELL EMITTED DURING INITIAL USAGE

Some parts of the cooker have been coated with a light covering of protective oil. During initial operation of the cooker, this may cause smoke/smell to be emitted and is normal and not a fault with the appliance, it is therefore advisable to open doors and or windows to allow for ventilation. Lift the lids to prevent staining the linings.

**For further advice or information please contact
your local distributor/stockist**

With Aga's policy of continuous product improvement, the Company reserves the right to change specifications and make modifications to the appliance described at any time.



Made by  AGA

Manufactured by
Aga