

## Built-in Refrigerator

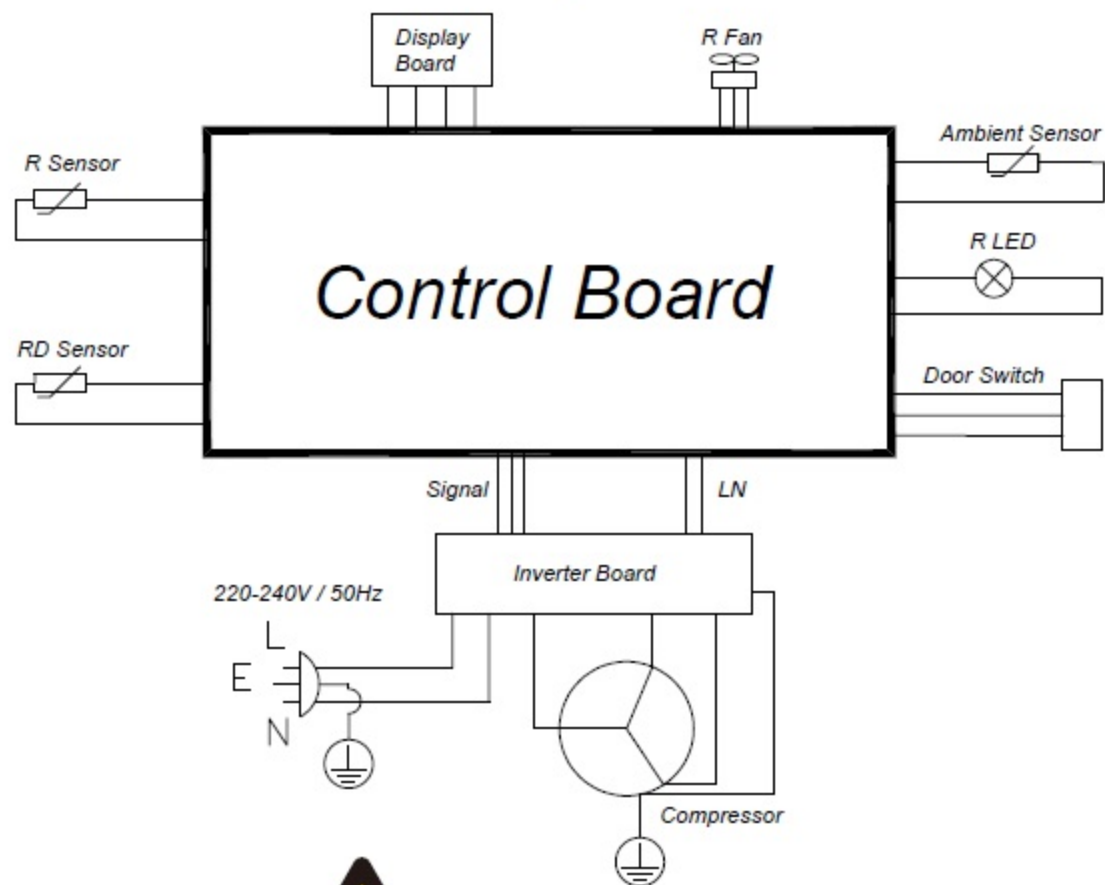

ELECTRO DEPOT  
1, route de Vendeville  
59155 FACHES THUMESNIL  
FRANCE  
Made in P.R.C

S/N: YY-WW-990399-XXXX

# VALBERG

990399 - BI 1D NF 304 D W625C (V1)

Lamp power	2W
Climate class	SN,N,ST,T
Protection against electric shock class	I
Voltage	AC220-240V
Frequency	50Hz
Current	0.79A
Total volume	304L
Fresh food compartment storage volume	304L
Energy class	D
Annual energy consumption	90 kWh/a
Refrigerant/ Amount	R600a(38g)
Foaming agent	CYCLOPENTANE
Noise	35dB(A)