

## Frost free Refrigerator-freezer

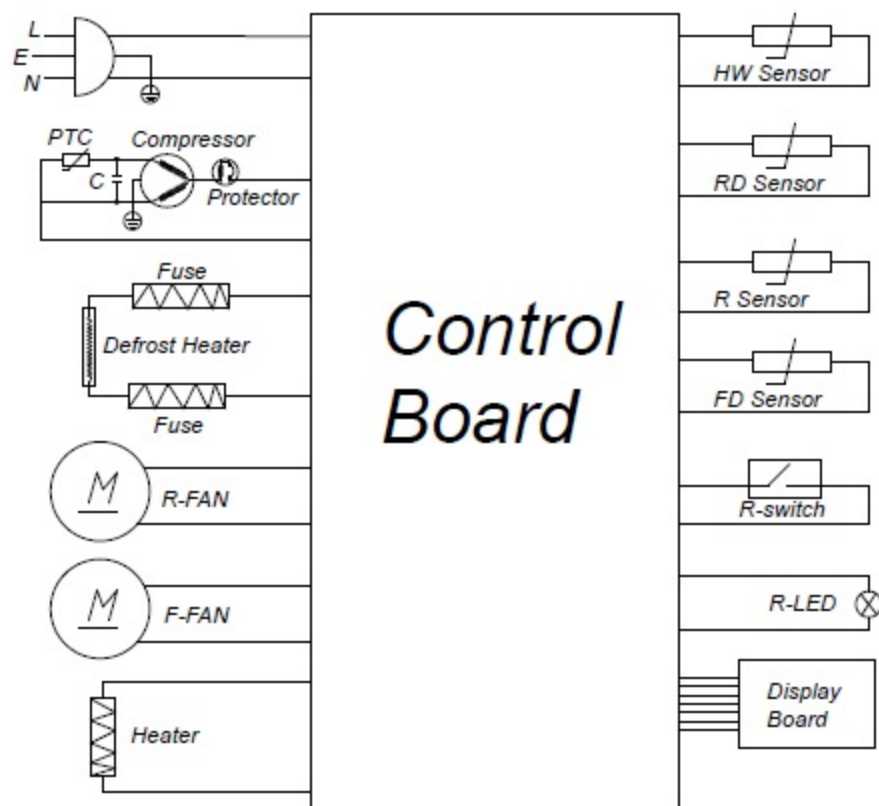

ELECTRO DEPOT  
1, route de Vendeville  
59155 FACHES THUMESNIL  
FRANCE  
Made in P.R.C

S/N: YY-WW-990408-XXXX

# VALBERG

990408 - BI CNF 248 E W625C (V1)

Lamp power	2W
Climate class	N,ST
Protection against electric shock class	I
Voltage	AC220-240V
Frequency	50Hz
Defrost power	180W
Current	0.8A
Total volume	248L
Fresh food compartment storage volume	180L
Four star compartment storage volume	* *** 68L
Energy class	E
Annual energy consumption	223 kWh/a
Freezing capacity	3.5kg/24h
Temperature rise time	6h
Refrigerant/ Amount	R600a(47g)
Foaming agent	CYCLOPENTANE
Noise	41dB(A)