

120

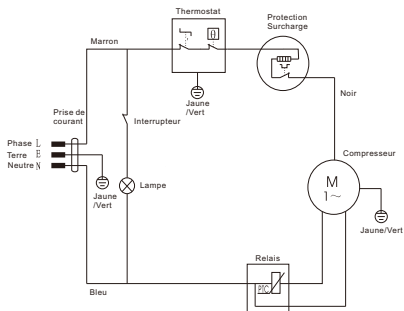

REFRIGERATEUR



| | |
|--|--------------|
| REFERENCE: | AFD1502A+X |
| TENSION NOMINALE: | 220-240V~ |
| COURANT NOMINAL: | 0.6A |
| FREQUENCE NOMINALE: | 50Hz |
| PUISSANCE DE LA LAMPE: | MAX 10W |
| VOLUME TOTAL: | 130L |
| CLASSE CLIMATIQUE: | N/ST |
| GAZ REFRIGERANT: | R600a(40g) |
| CONSOMMATION ENERGETIQUE: | 0.48kWh/24h |
| CLASSE DE PROTECTION CONTRE CHOC ELECTRIQUE: | I |
| POIDS NET: | 33kg |
| MOUSSE D'ISOLATION: | CYCLOPENTANE |
| CLASSE ENERGETIQUE: | A+ |
| NO. DE SERIE: | WWYY00001 |

BUT INTERNATIONAL
1, AVENUE SPINOZA
77184 EMERAINVILLE, FRANCE
FABRIQUE EN RPC



80