

Qilive

600168929
600129816

HQ-611RWEN(CE-BCD470WE-KT)

Rated voltage 220 - 240 V~

Rated frequency 50 Hz

Rated current 1.8 A

Lamp rated power 6 W

Rated defrost power 250 W

Annual energy consumption AE 237 kWh/a

Energy consumption E16 0.375 kWh/24h

Energy consumption E32 0.885 kWh/24h

Total volume 474 L

Fresh food compartment volume 305 L

Freezer compartment volume 169 L

Four-star compartment volume 169 L

Climate classification SN/N/ST/T

Classification of protection against electric shock class I

Refrigerant and inject amount R600a/63g

Net weight 93 kg

Freezing capacity 13 kg/24h

Temperature rise value 12 h

Insulation blowing agent Cyclopentane

Compressor DZ90A1M

CE



Refrigerator-Freezer Diagram of Circuit Principles

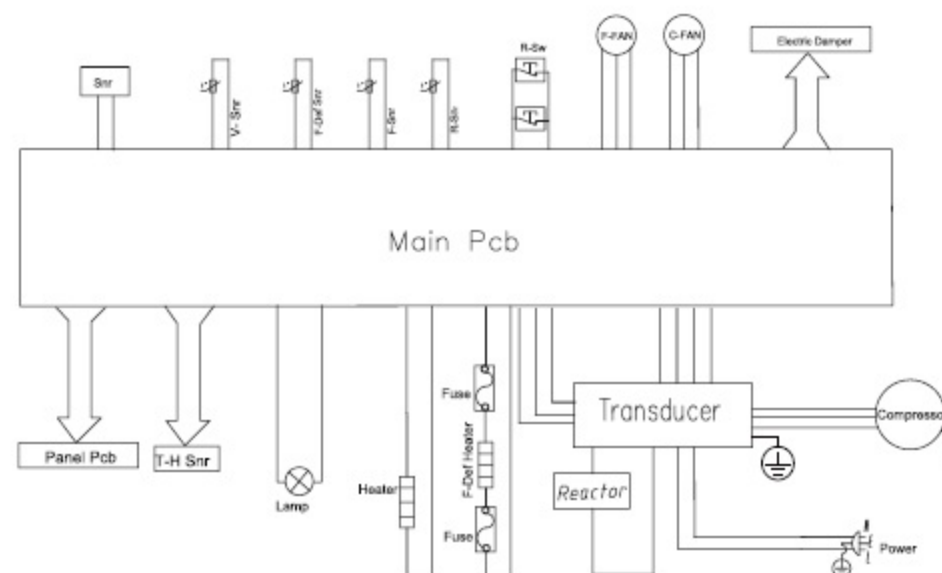

SAS OIA, 200, rue de la Recherche, Le Colibri BP 169,
59650 Villeneuve d'Ascq, France

www.auchan-retail.com/contact

Made in China/Сделано в Китае

SN:170868375000001