

Qilive

CE



154617 / HD-359RWENJ

Rated voltage

220 - 240 V~

Rated frequency

50 Hz

Rated current

0.6A

Lamp Rated Power

MAX 2W

Rated Defrost Power

160W

Energy consumption

219 kWh/a

Energy consumption E16

0.360 kWh/24h

Energy consumption E32

0.840 kWh/24h

Total volume

270 L

Fresh food compartment Volume

199 L

Four-star compartment Volume

71 L

Climate classification

N/ST

Classification of protection
against electric shock Class

I

Refrigerant and inject amount

R600a/38g

Net weight

54 kg

Freezing Capacity

3.5 kg/24h

Temperature rise value

7h

Insulation Blowing Agent

Cyclopentane

Diagram of Circuit Principles

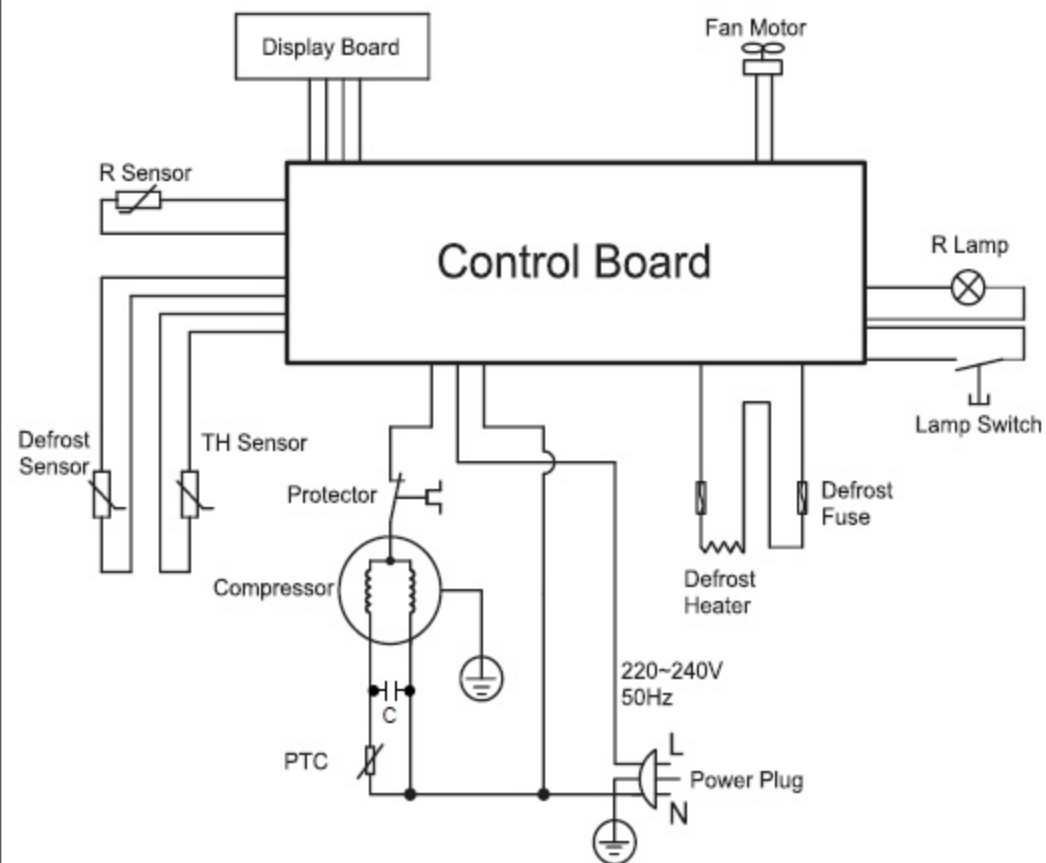

SAS OIA, 200, rue de la Recherche, Le Colibri BP 169,

59650 Villeneuve d'Ascq, France

www.auchan-retail.com/contact

Made in China/Сделано в Китае

SN : 220369384000001