

Frost free Refrigerator-freezer Type II

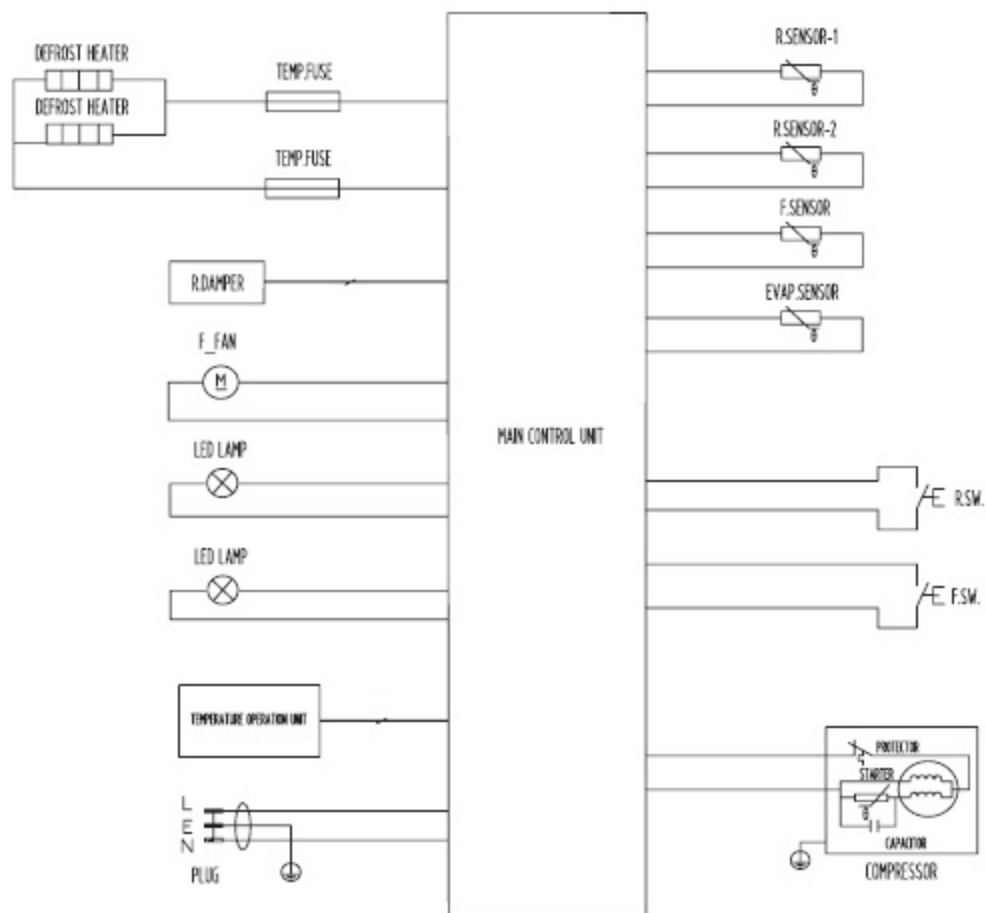

ELECTRO DEPOT
1,route de Vendeville
59155 FACHES THUMESNIL
FRANCE
Made in P.R.C

VALBERG

Model	958121	SBS 516 A+ X180C
Climate class		SN, N, ST
Protection against electric shock class		I
Voltage		220-240 V ~
Frequency		50 Hz
Defrost power		240 W
Current		1,6 A
MAX wattage of LED		2 W+2 W
Total gross volume		566 L
Total storage volume		516 L
Frozen food volume	* ** *	177 L
Fresh food volume		339 L
Energy class		A+
Annual energy consumption		411 kWh/year
Refrigerant/Amount		R600a / 68g
Foaming agent		Cyclopentane
Noise		43 dB(A)
Freezing capacity		11 kg/24h
Temperature rise time		10 h

S/N :YY-WW-958121-XXXXX

