

## Frost free Refrigerator-freezer

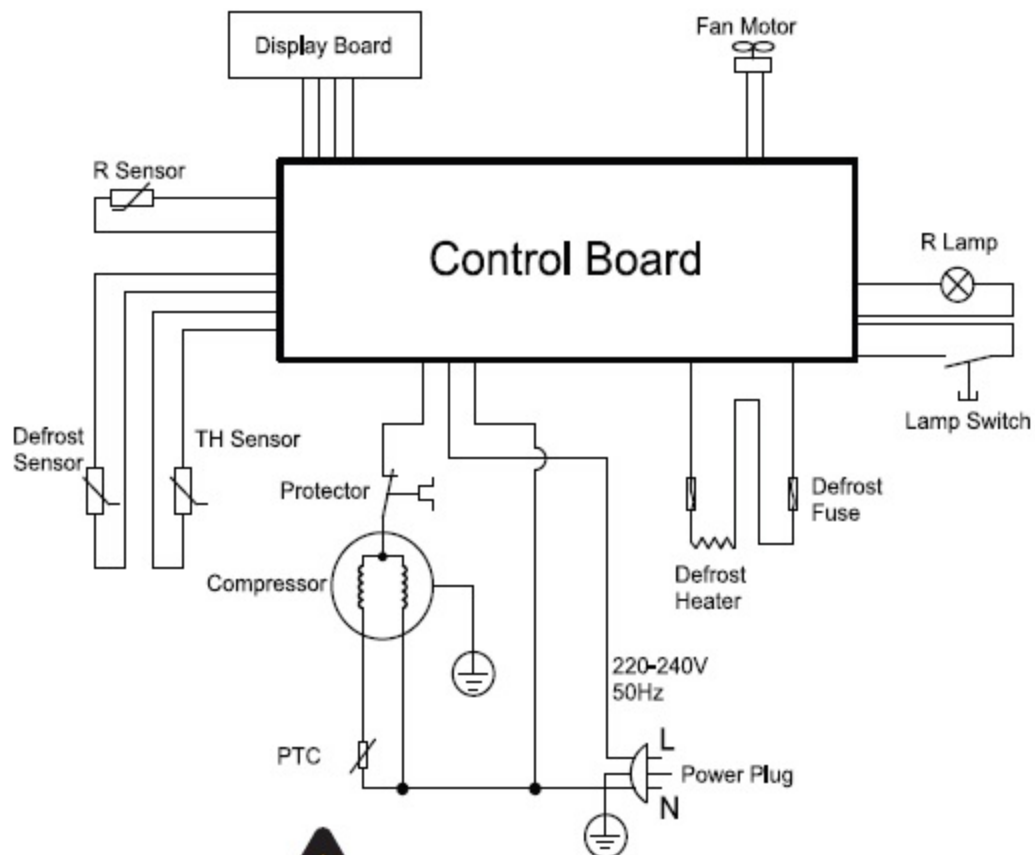

ELECTRO DEPOT  
1, route de Vendeville  
59155 FACHES THUMESNIL  
FRANCE  
Made in P.R.C

S/N: YY-WW-975169-XXXX

# VALBERG

975169 - CNF 270 F W625C2 (V1)

|   |                     |
|---|---------------------|
| Lamp power                              | 2W                  |
| Climate class                           | N,ST                |
| Protection against electric shock class | I                   |
| Voltage                                 | AC220-240V          |
| Frequency                               | 50Hz                |
| Defrost power                           | 160W                |
| Current                                 | 0.8A                |
| Total volume                            | 270L                |
| Fresh food compartment storage volume   | 199.0L              |
| Four star compartment storage volume    | <b>* ** *</b> 71.0L |
| Energy class                            | F                   |
| Annual energy consumption               | 274 kWh/a           |
| Freezing capacity                       | 3.5kg/24h           |
| Temperature rise time                   | 7h                  |
| Refrigerant/ Amount                     | R600a(34g)          |
| Foaming agent                           | CYCLOPENTANE        |
| Noise                                   | 41dB(A)             |