

# Frost free Refrigerator-freezer Type II

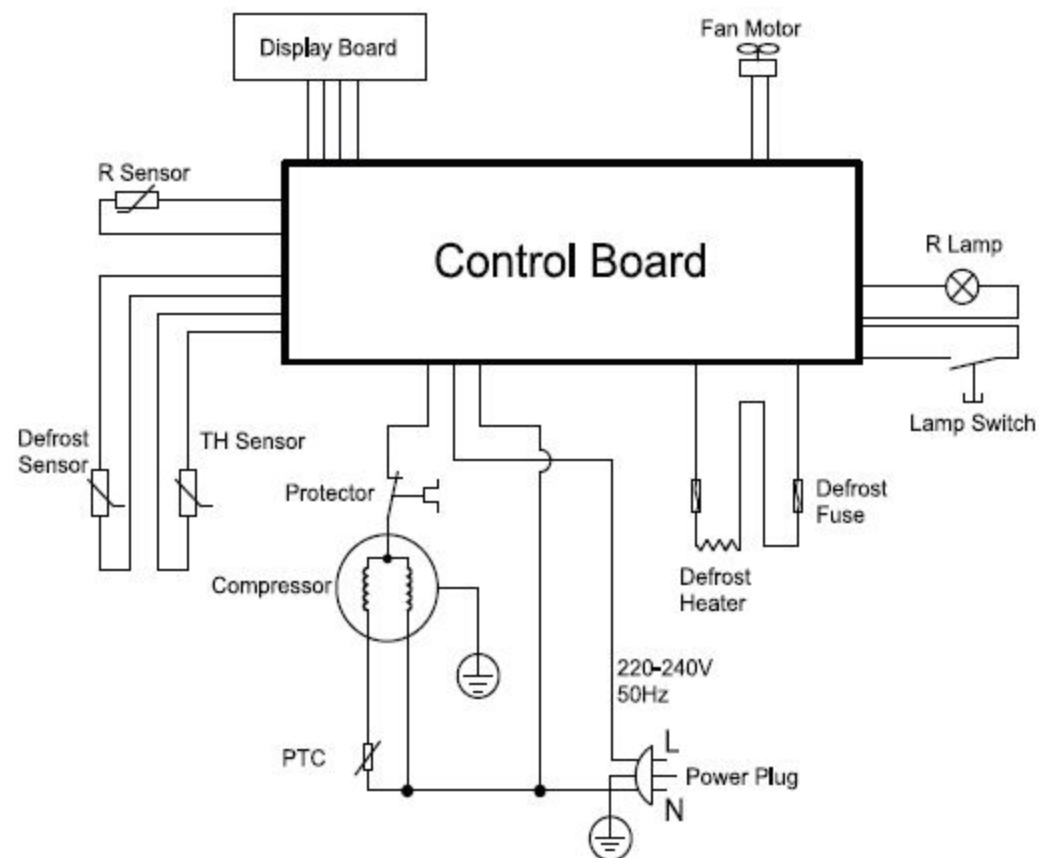

S/N: YY-WW-975263-XXXX  
Made in P.R.C

ELECTRO DEPOT  
1, route de Vendeville  
59155 FACHES THUMESNIL FRANCE

# VALBERG

975263 - CNF 268 F WD S625C2 (V1)

|   |              |
|---|--------------|
| Lamp power                              | 2W           |
| Climate class                           | N,ST         |
| Protection against electric shock class | I            |
| Voltage                                 | AC220-240V   |
| Frequency                               | 50Hz         |
| Defrost power                           | 160W         |
| Current                                 | 0.8A         |
| Total volume                            | 268L         |
| Fresh food compartment storage volume   | 197.0L       |
| Four star compartment storage volume    | * ** *       |
| Energy class                            | F            |
| Annual energy consumption               | 274 kWh/a    |
| Freezing capacity                       | 3.5kg/24h    |
| Temperature rise time                   | 7h           |
| Refrigerant/ Amount                     | R600a(34g)   |
| Foaming agent                           | CYCLOPENTANE |
| Noise                                   | 41dB(A)      |