

Frost free Refrigerator-freezer Type II

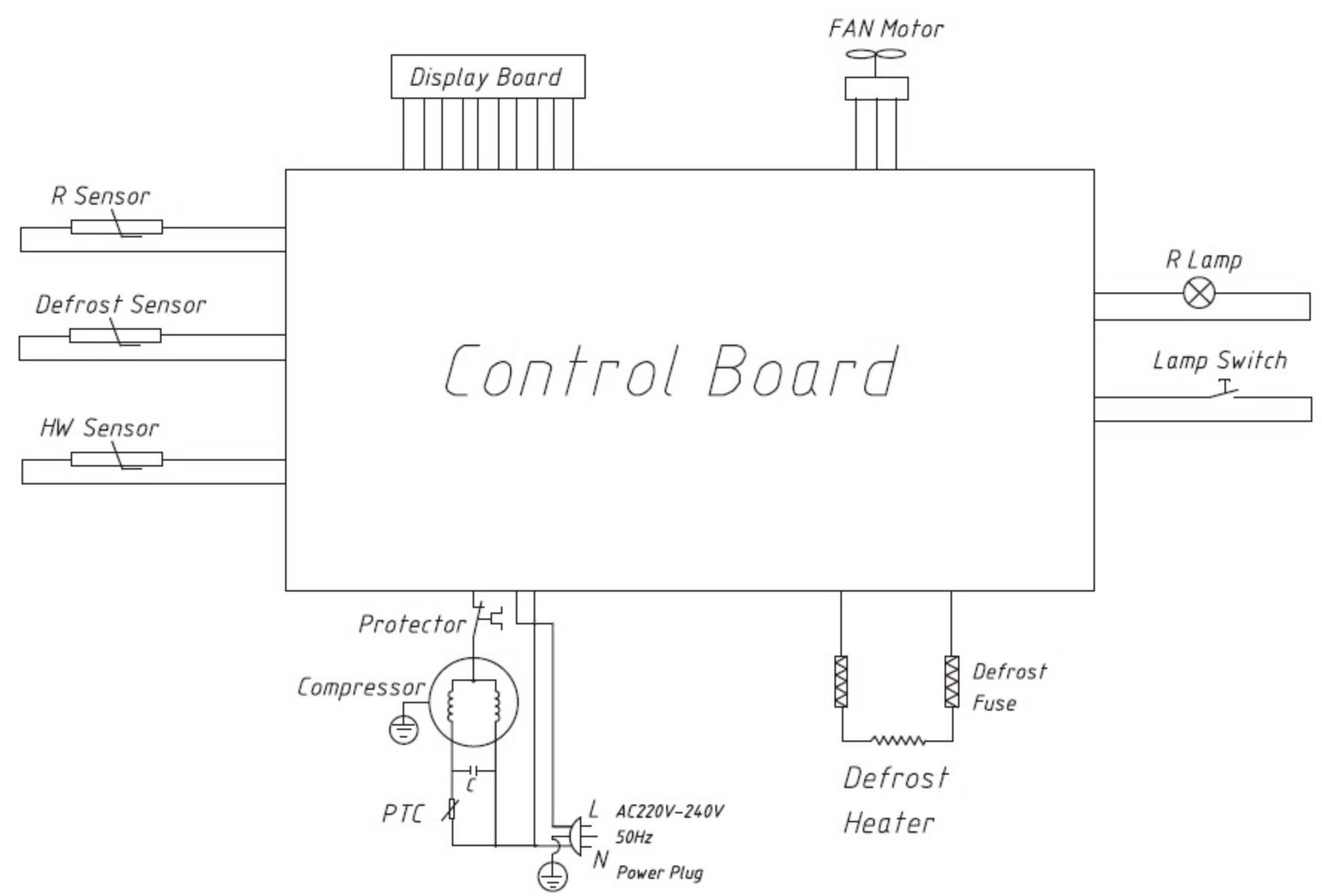

VALBERG

978944 - CNF 268 E WD X625C (V1)

| | |
|---------------------------------------|--------------|
| Lamp power | 2W |
| Climate Class | N/ST |
| Protection Against Electric Shock | I |
| Voltage | AC220-240V |
| Frequency | 50Hz |
| Defrost power | 160W |
| Current | 0.6A |
| Total volume | 268L |
| Fresh food compartment storage volume | 197.0L |
| Four star compartment storage volume | 71.0L |
| Energy class | E |
| Annual energy consumption | 219 kWh/a |
| Freezing capacity | 3.5kg/24h |
| Temperature rise time | 7h |
| Refrigerant/ Amount | R600a(38g) |
| Foaming agent | CYCLOPENTANE |
| Noise | 41dB(A) |



S/N: YY-WW-978944-XXXX
 Made in P.R.C



ELECTRO DEPOT
 1,route de Vendeville
 59155 FACHES THUMESNIL FRANCE