

Frost free Refrigerator-freezer

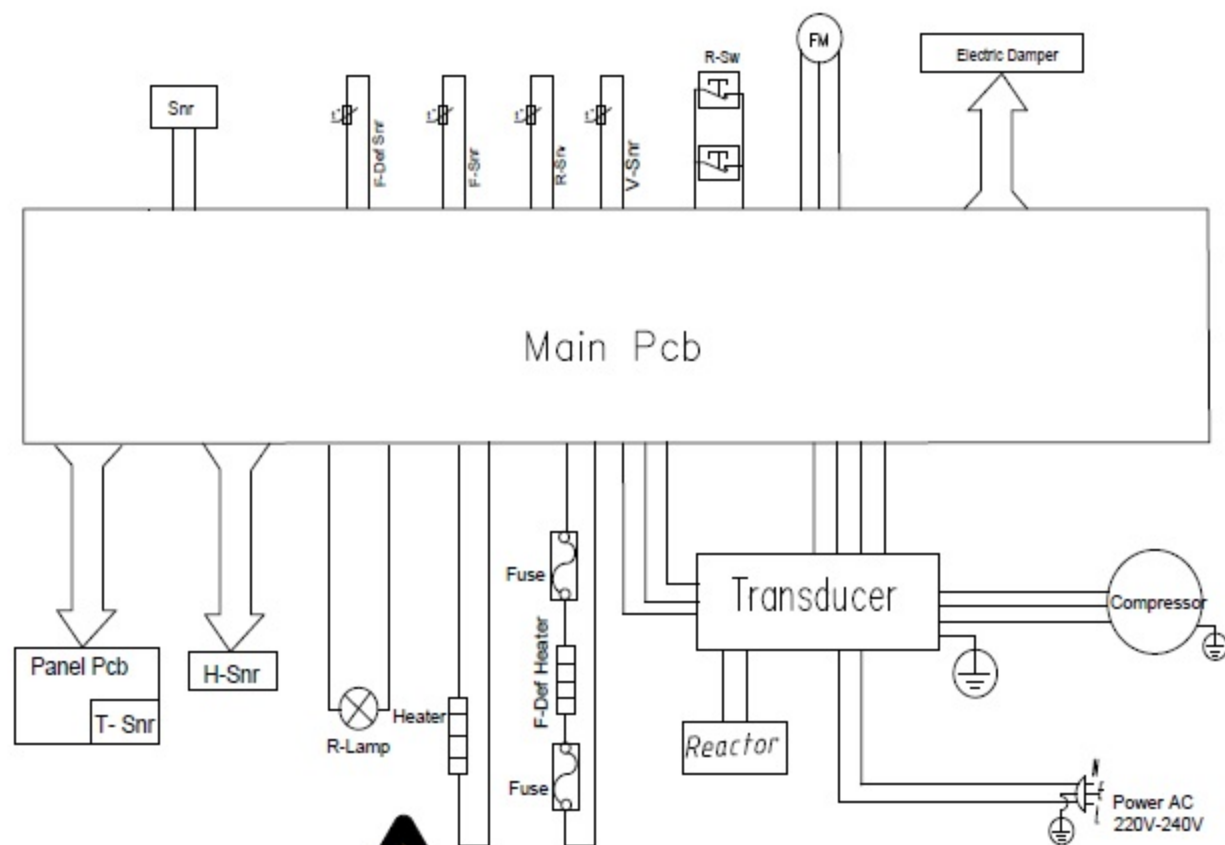

ELECTRO DEPOT
 1,route de Vendeville
 59155 FACHES THUMESNIL
 FRANCE
 Made in P.R.C

S/N: YY-WW-977494-XXXX

VALBERG

977494 - 4D 516 E X625C (V1)

Rated Voltage	220-240V~
Rated Frequency	50Hz
Climate Classification	SN/N/ST/T
Rated Current	1.9A
Lamp Rated Power	5W
Rated Defrost Power	250W
Refrigerant	R600a
Amount	63g
Total Volume	516L
Four-star Compartment Volume	*** 169L
Fresh Food Compartment Volume	347L
Annual Energy Consumption AE	306kWh/a
Energy Consumption E16	0.455kWh/24h
Energy Consumption E32	1.181kWh/24h
Auxiliary Energy Consumption	7.077kWh/a
Freezing Capacity	12kg/24h
Temperature Rise value	7h
Protection Against Electric Shock Class	I
Insulation Blowing Agent	Cyclopentane

