

# Frost free Refrigerator-freezer

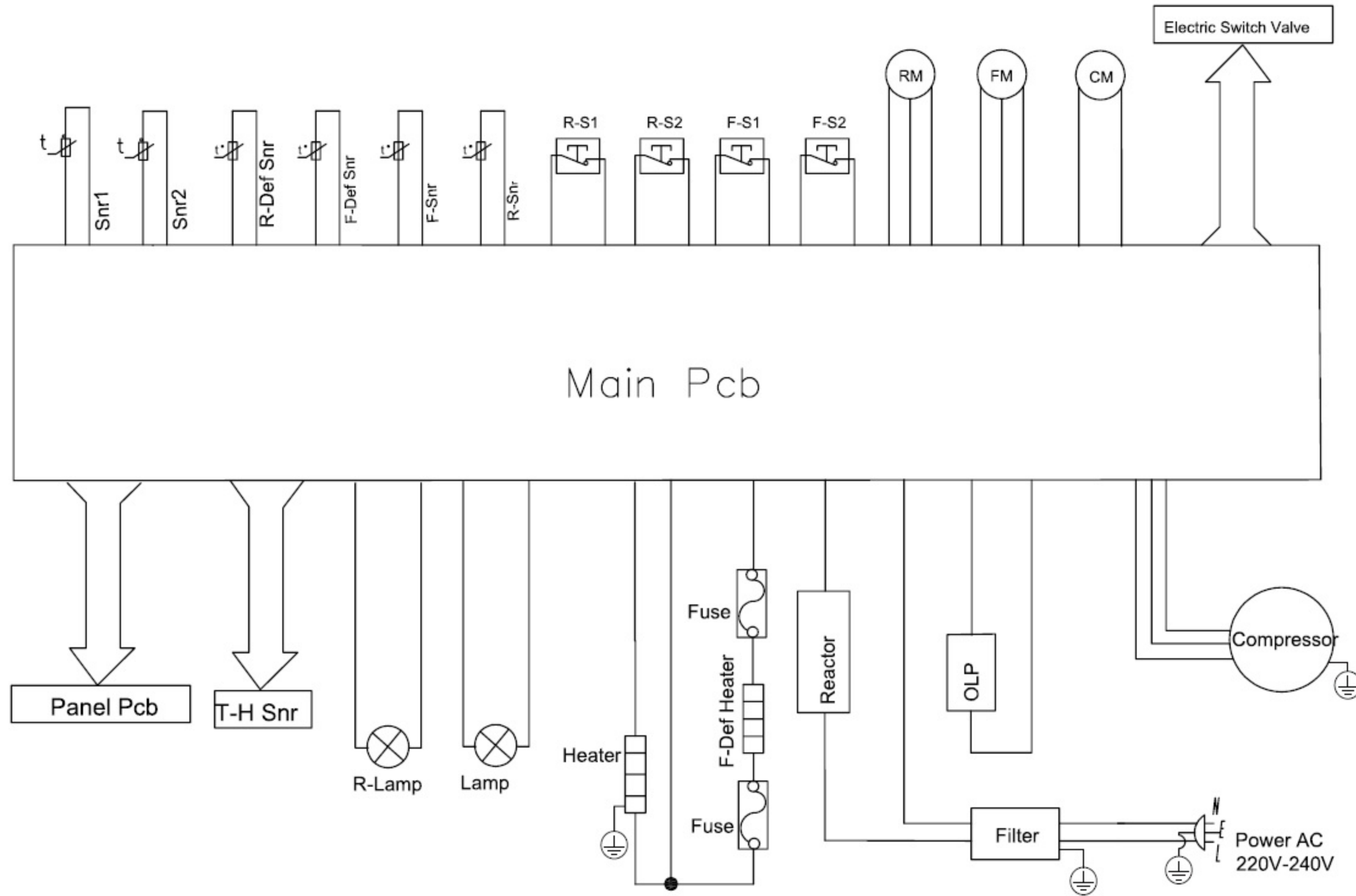

ELECTRO DEPOT  
1,route de Vendeville  
59155 FACHES THUMESNIL  
FRANCE  
Made in PRC

S/N: YY-VVV-984219-XXXX

# VALBERG

984219 - 4D 511 D DX625C (V1)

Rated Voltage	220-240V~
Rated Frequency	50Hz
Climate Classification	SN/N/ST/T
Rated Current	1.9A
Lamp Rated Power	6W
Rated Defrost Power	250W
Refrigerant	R600a
Amount	72g
Total Volume	511L
Fresh Food Compartment Volume	341L
Freezer Compartment Volume	170L
Annual Energy Consumption AE	244kWh/a
Energy Consumption E16	0.372kWh/24h
Energy Consumption E32	0.911kWh/24h
Auxiliary Energy Consumption	8.983kWh/a
Freezing Capacity	12kg/24h
Temperature Rise Value	15h
Protection Against Electric Shock Class	I
Insulation Blowing Agent	Cyclopentane