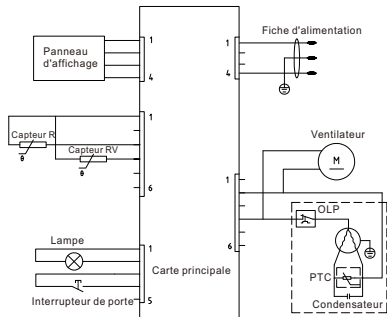

120

*Signature***REFRIGERATEUR**

REFERENCE:	SRB4003A+X AQUA
TENSION NOMINALE:	220-240V~
COURANT NOMINAL:	2.0A
FREQUENCE NOMINALE:	50Hz
PUISSANCE DE LA LAMPE:	2W
VOLUME TOTAL:	422L
CLASSE CLIMATIQUE:	N/ST
GAZ REFRIGERANT:	R600a(110g)
CONSOMMATION ENERGETIQUE:	0.9kWh/24h
CLASSE DE PROTECTION CONTRE CHOC ELECTRIQUE:	I
POIDS NET:	73kg
MOUSSE D'ISOLATION:	CYCLOPENTANE
CLASSE ENERGETIQUE:	A+
NO. DE SERIE:	WWYY00001

80

BUT INTERNATIONAL  
1, AVENUE SPINOZA  
77184 EMERAINVILLE, FRANCE  
FABRIQUE EN RPC

