

120

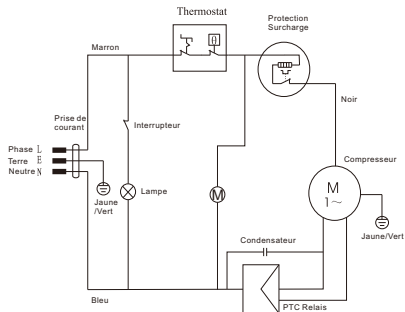

REFRIGERATEUR



REFERENCE:	SRB4001A+X
TENSION NOMINALE:	220-240V~
COURANT NOMINAL:	0.8A
FREQUENCE NOMINALE:	50Hz
PUISSANCE DE LA LAMPE:	2W
VOLUME TOTAL:	422L
CLASSE CLIMATIQUE:	N/ST
GAZ REFRIGERANT:	R600a(110g)
CONSOMMATION ENERGETIQUE:	0.88kWh/24h
CLASSE DE PROTECTION CONTRE CHOC ELECTRIQUE:	I
POIDS NET:	77kg
MOUSSE D'ISOLATION:	CYCLOPENTANE
CLASSE ENERGETIQUE:	A+
NO. DE SERIE:	WWYY00001

BUT INTERNATIONAL
1, AVENUE SPINOZA
77184 EMERAINVILLE, FRANCE
FABRIQUE EN CHINE



80