

# SIGNATURE® REFRIGERATEUR-CONGELATEUR

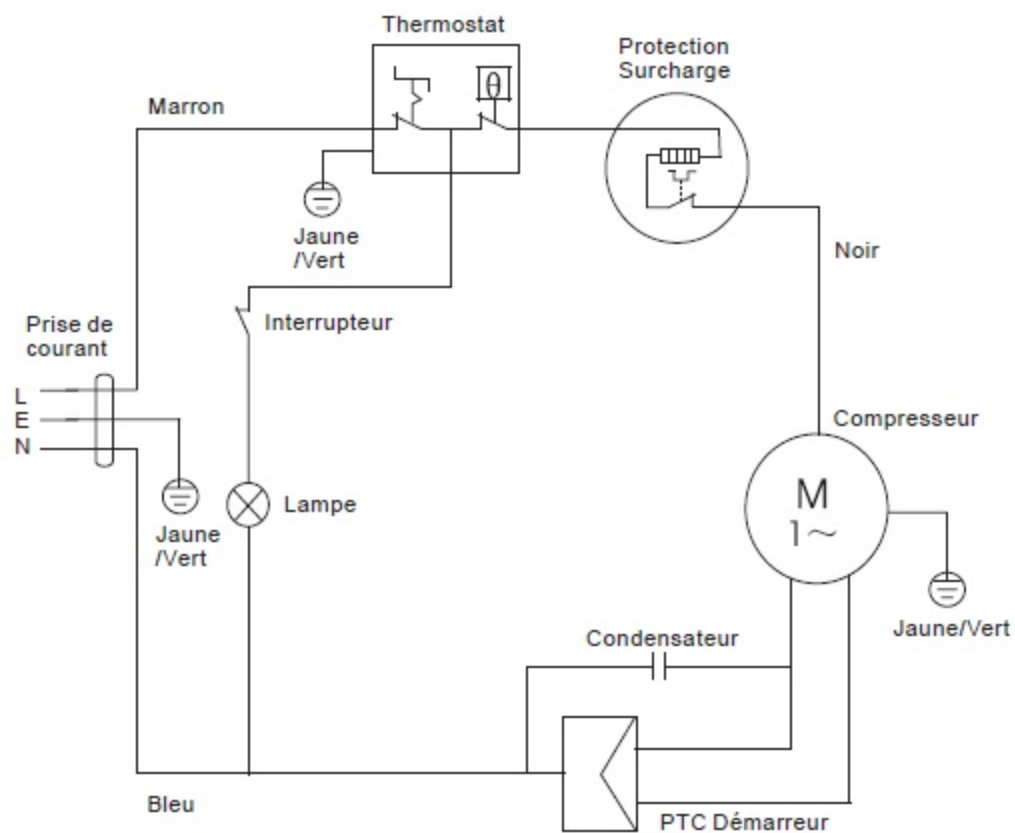

REFERENCE:	SDP211VRE
TENSION NOMINALE:	220-240V~
COURANT NOMINAL:	0.6A
FREQUENCE NOMINALE:	50Hz
PUISSANCE DE LA LAMPE:	LED 2W
VOLUME UTILE TOTAL:	211L
VOLUME UTILE DU REFRIGERATEUR:	172L
VOLUME UTILE DU CONGELATEUR:	39L
CLASSE CLIMATIQUE:	N/ST
GAZ REFRIGERANT:	R600a(52g)
CONSOMMATION D'ENERGIE DE E32:	0.702 kWh/24h
CONSOMMATION D'ENERGIE ANNUELLE:	174 kWh/a
AUTONOMIE:	10h
POUVOIR DE CONGELATION:	2.0kg/24h
CLASSE DE PROTECTION CONTRE CHOC ELECTRIQUE:	I
POIDS NET:	42.0 kg
MOUSSE D'ISOLATION:	CYCLOPENTANE
CLASSE ENERGETIQUE:	E
NO. DE SERIE:	WWYY00001

BUT INTERNATIONAL  
1, AVENUE SPINOZA  
77184 EMERAINVILLE, FRANCE  
FABRIQUE EN CHINE

