

SIGNATURE CONGELATEUR VERTICAL

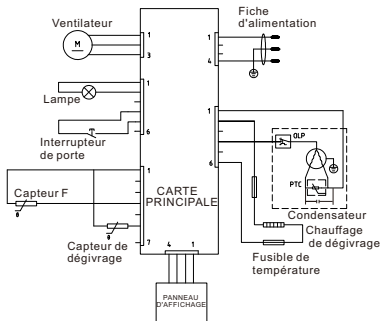

REFERENCE:	SCA2605XNF
TENSION NOMINALE:	220-240V~
COURANT NOMINAL:	2.0A
FREQUENCE NOMINALE:	50Hz
DEGIVRAGE D'ALIMENTATION:	150W
VOLUME UTILE TOTAL:	282L
VOLUME UTILE DU CONGELATEUR:	282L
CLASSE CLIMATIQUE:	N/ST
GAZ REFRIGERANT:	R600a(40g)
CONSOMMATION D'ÉNERGIE DE E16:	0.531kWh/24h
CONSOMMATION D'ÉNERGIE DE E32:	1.019kWh/24h
CONSOMMATION D'ÉNERGIE ANNUELLE:	283kWh/a
AUTONOMIE:	18h
POUVOIR DE CONGELATION:	13kg/24h
CLASSE DE PROTECTION CONTRE CHOC ELECTRIQUE:	I
POIDS NET:	64kg
MOUSSE D'ISOLATION:	CYCLOPENTANE
CLASSE ENERGETIQUE:	F
NO. DE SERIE:	

WWYY00001

BUT INTERNATIONAL
1, AVENUE SPINOZA
77184 EMERAINVILLE, FRANCE
FABRIQUE EN RPC

