

130±1

85±1

SIGNATURE

CAVE A VIN

Diagramme des circuits

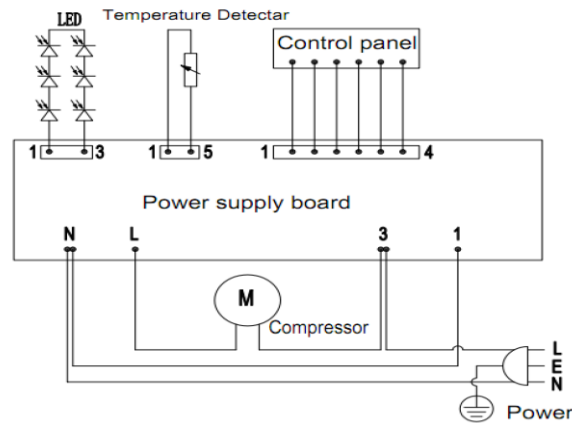

REFERENCE:	S24N
TENSION NOMINALE:	220-240V~
FREQUENCE NOMINALE:	50Hz
CONSOMMATION ENERGETIQUE E16	0.115kWh/24h
CONSOMMATION ENERGETIQUE E32	0.635kWh/24h
COURANT NOMINAL:	0.5A
PUISSANCE DE LA LAMPE:	1W
VOLUME UTILE:	65L
CLASSE CLIMATIQUE	SN, N
GAZ REFRIGERANT	R600a(16g)
CLASSE DE PROTECTION CONTRE CHOC ELECTRIQUE	CLASSE I
POIDS NET:	23kg
MOUSSE D'ISOLATION:	CYCLOPENTANE
N° DE SERIE:	WWYY00001-1240

BUT INTERNATIONAL
1, AVENUE SPINOZA
77184 EMERAINVILLE, France
FABRIQUE EN CHINE



85±1

90±1

