

RK3326 Part- N

M1528I Circuit diagram

U1000- N

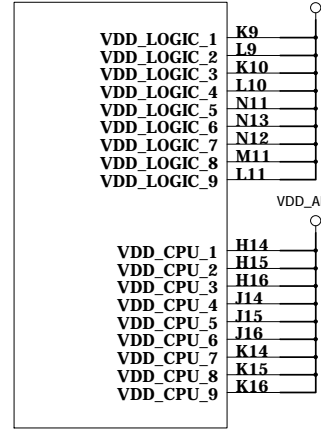

VDD_LOG Trace>60mil(1.5A)

VDD_ARM Trace>60mil(1.5A)

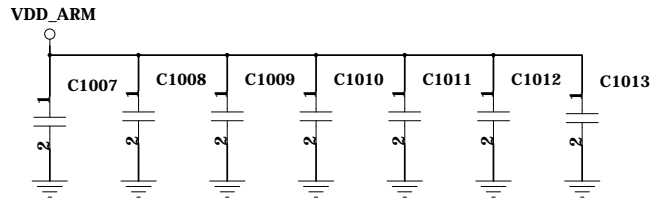
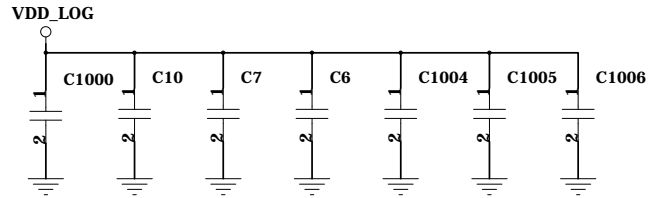

Note:All the Power filter capacitors should be placed close to the power pins of RK3326

RK3326 Part- C

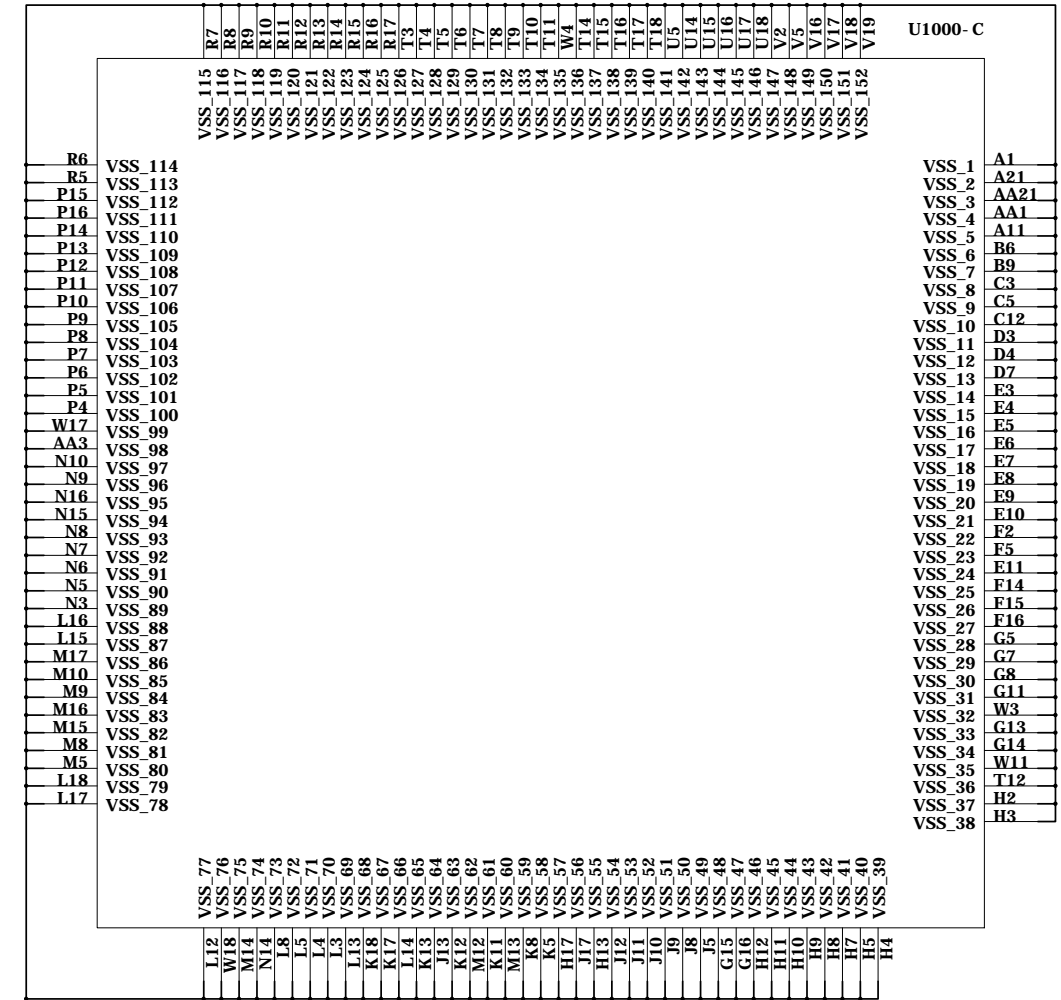

Project:			
File:			
Date:	Tuesday, January 02, 2018	Rev:	V0.1
Designed by:	Linus	Sheet:	11 of 99

RK3326 Part- N

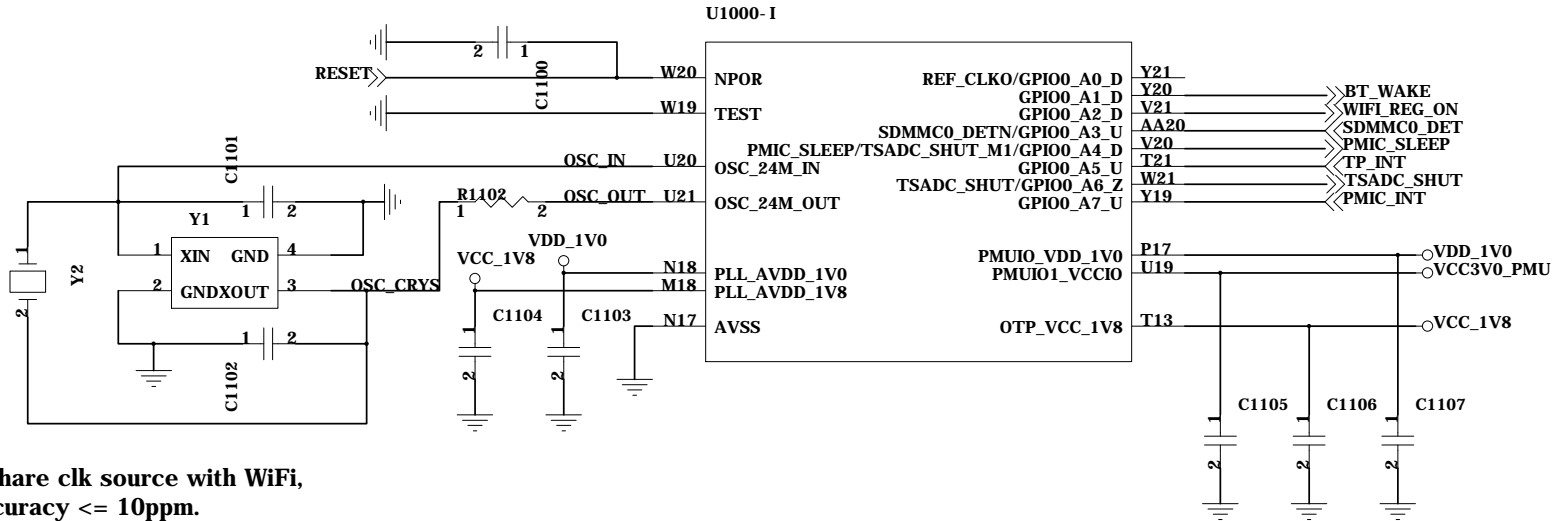

If share clk source with WiFi,
Accuracy <= 10ppm.
Otherwise <=20ppm for
Independent crystal design

RK3326 Part- J

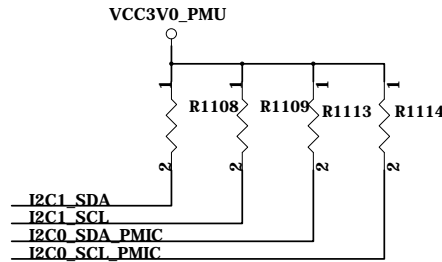
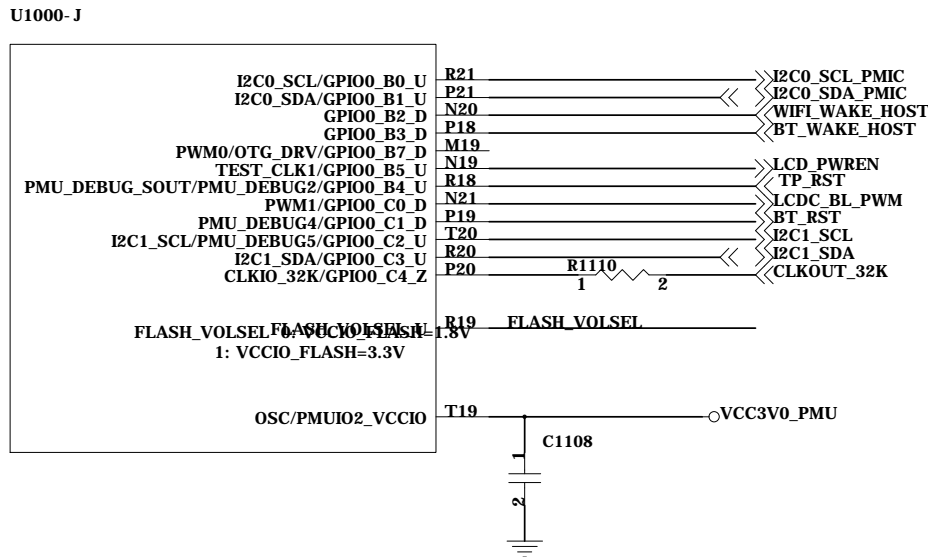

Note:

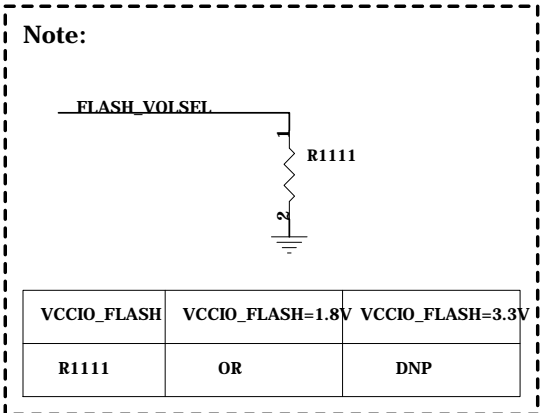

Project:			
File:			
Date:	Tuesday, January 02, 2018	Rev:	V0.1
Designed by:	Linus	Sheet:	11 of 99

RK3326 Part- A

U1000- A

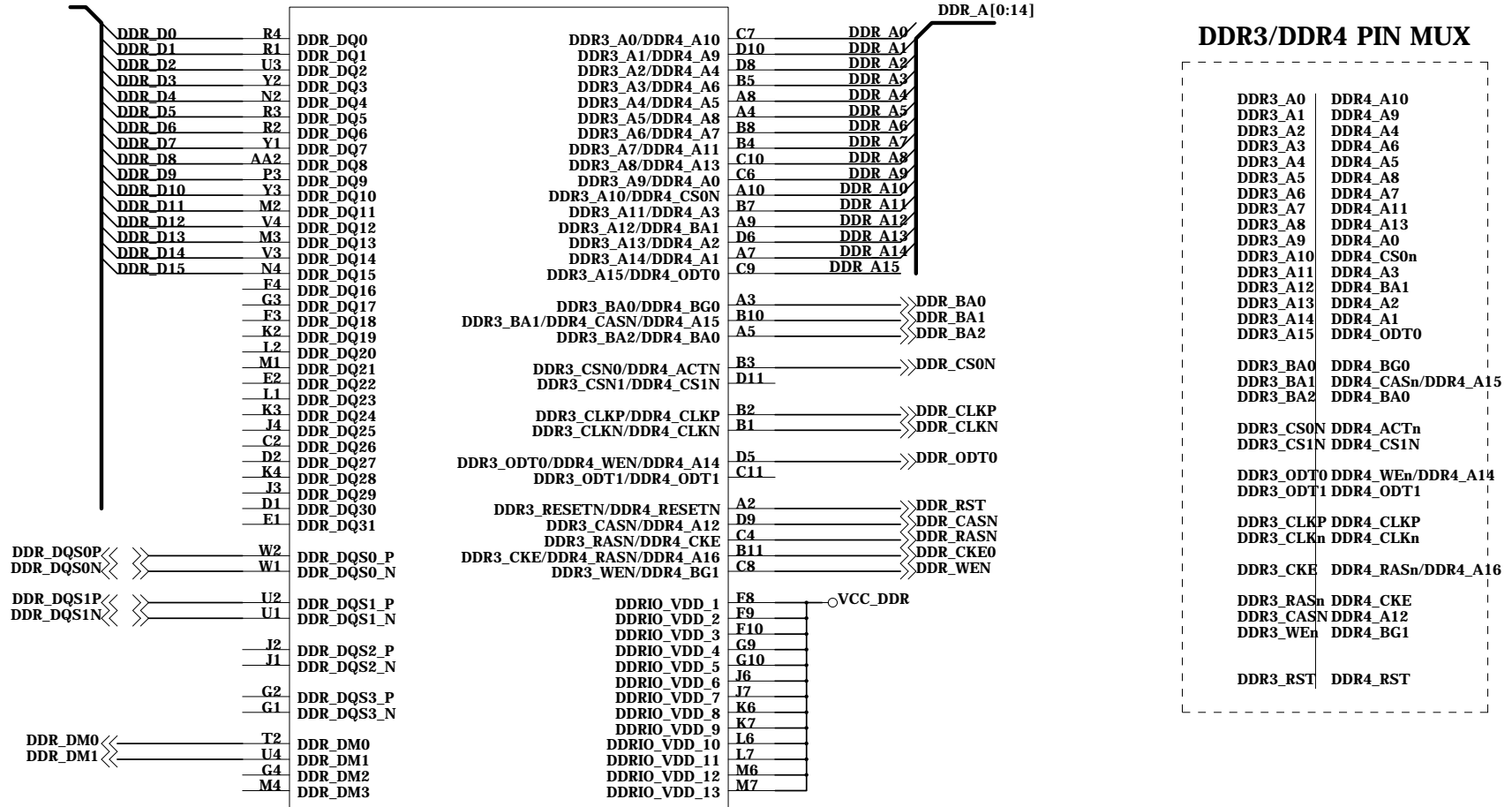

Power Filter

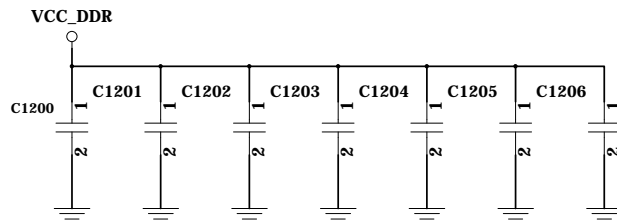

Note: All the Power filter capacitors should be placed close to the power pins of RK3326

Project:			
File:			
Date:	Tuesday, January 02, 2018	Rev:	V0.1
Designed by:	Linus	Sheet:	11 of 99

RK3326 Part- L

U1000-L

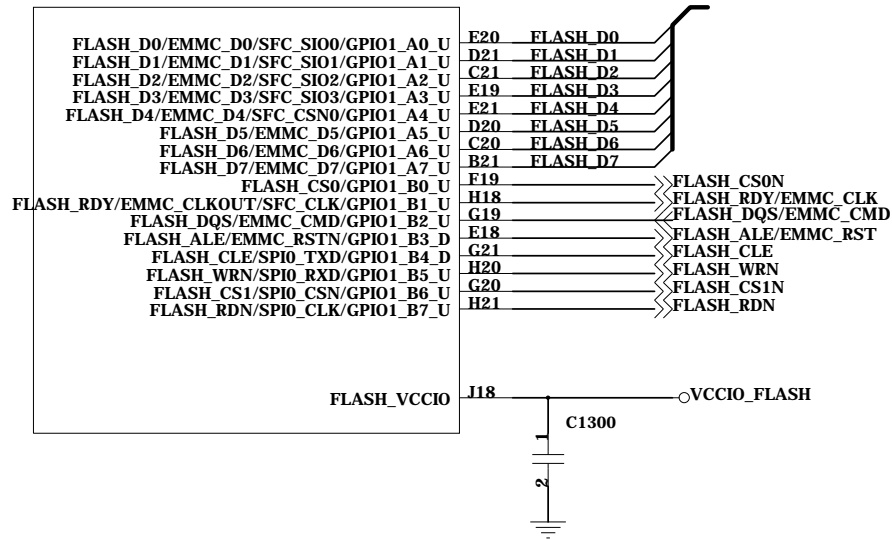

Project:			
File:			
Date:	Tuesday, January 02, 2018	Rev:	V0.1
Designed by:	Linus	Sheet:	11 of 99

RK3326 Part- E

U1000- E

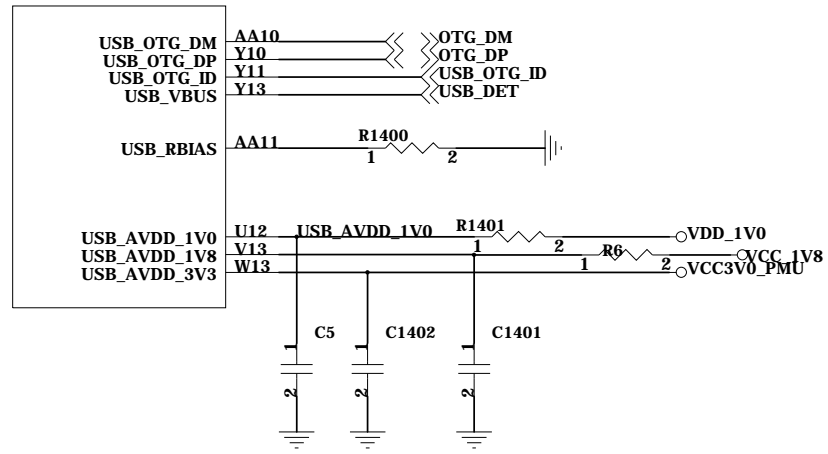

Project:			
File:			
Date:	Tuesday, January 02, 2018	Rev:	V0.1
Designed by:	Linus	Sheet:	11 of 99

RK3326 Part- F

U1000- F

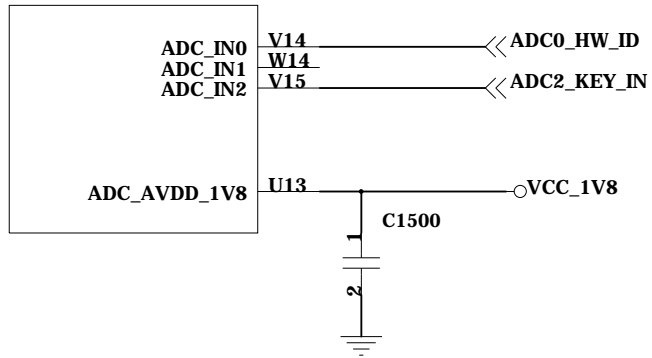

Key Name	SARADC
VOL+/RECOVERY	10
VOL-	170

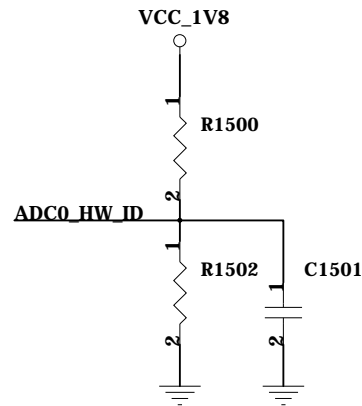

Project:			
File:			
Date:	Tuesday, January 02, 2018	Rev:	V0.1
Designed by:	Linus	Sheet:	11 of 99

RK3326 Part- D

RK3326 Part- B

U1000- D

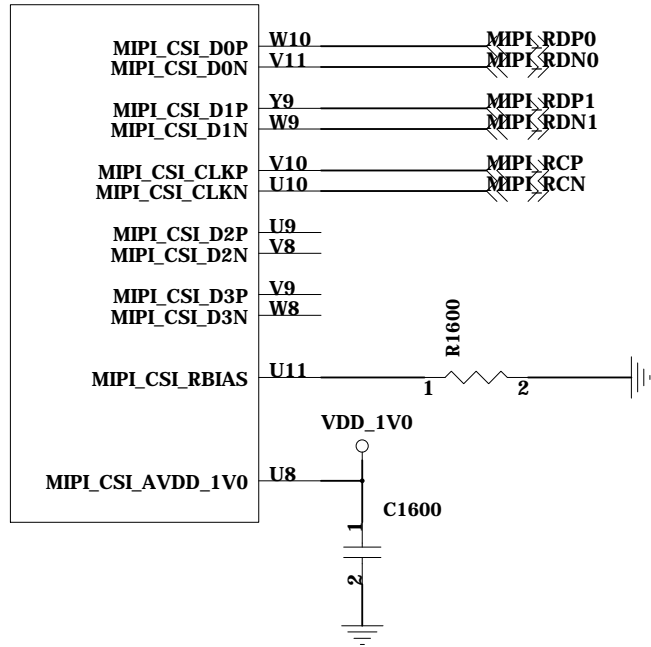

U1000- B

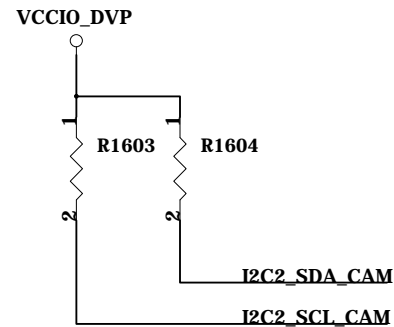
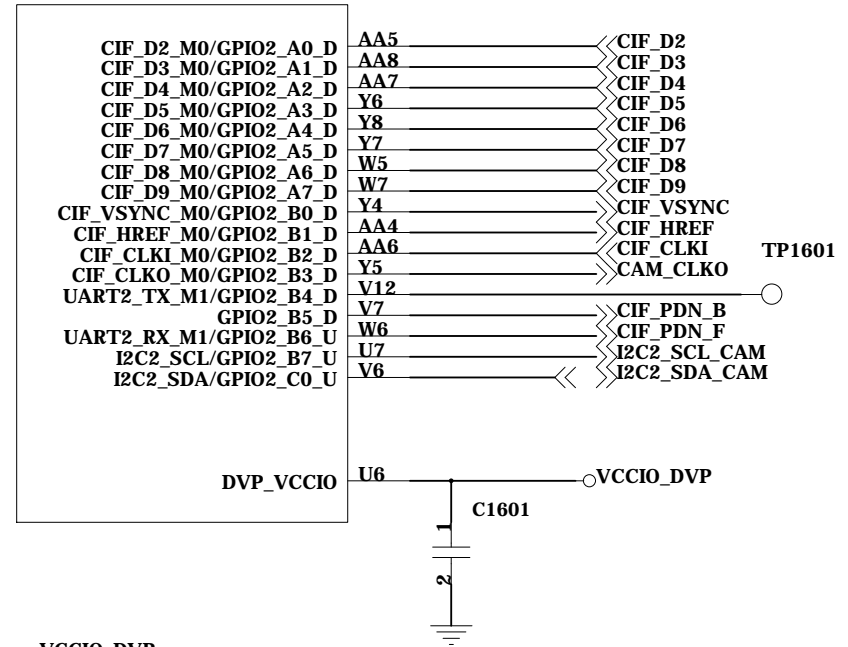

Project:			
File:			
Date:	Tuesday, January 02, 2018	Rev:	V0.1
Designed by:	Linus	Sheet:	11 of 99

RK3326 Part- F

U1000- M

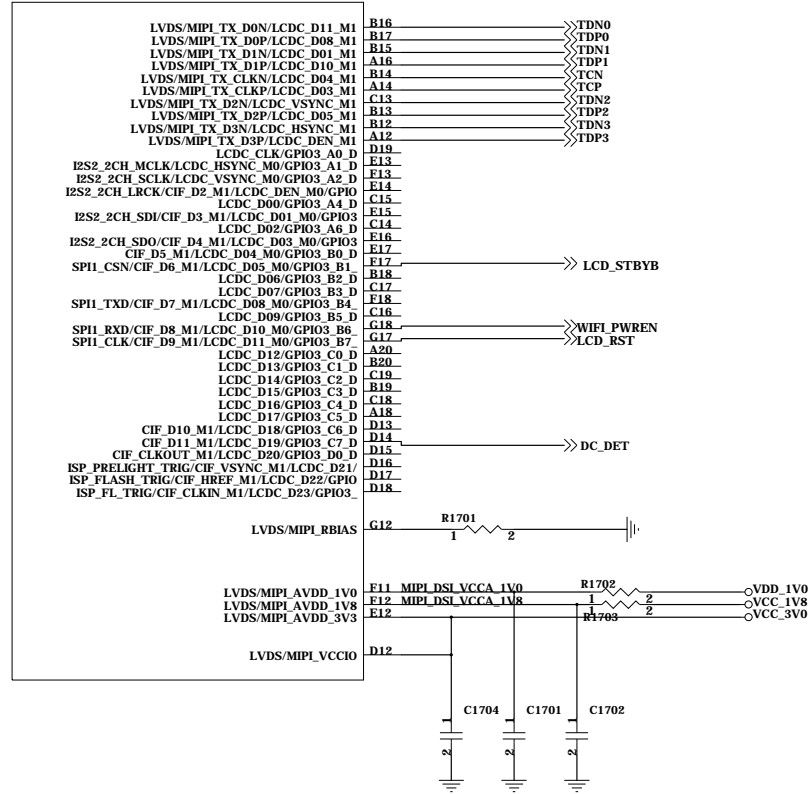

Project:			
File:			
Date:	Tuesday, January 02, 2018	Rev:	V0.1
Designed by:	Linus	Sheet:	11 of 99

RK3326 Part- K

U1000- K

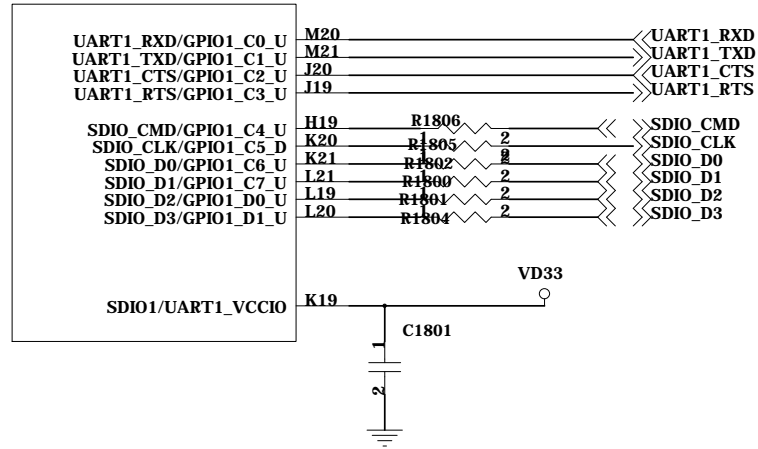

RK3326 Part- G

U1000- G

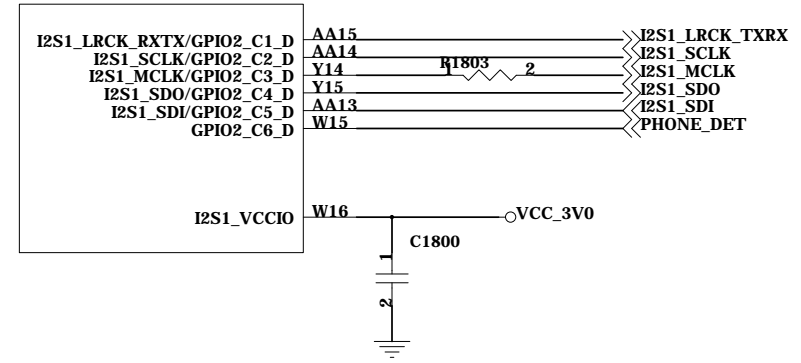

RK3326 Part- H

U1000- H

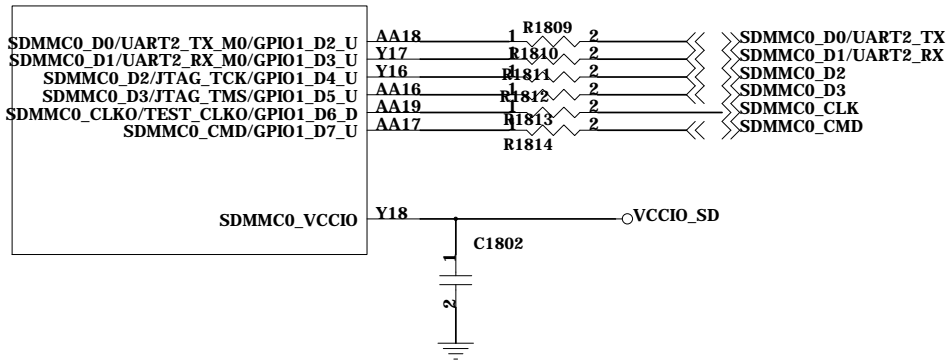

Project:			
File:			
Date:	Tuesday, January 02, 2018	Rev:	V0.1
Designed by:	Linus	Sheet:	11 of 99

PMIC RK817- 1 DCDC

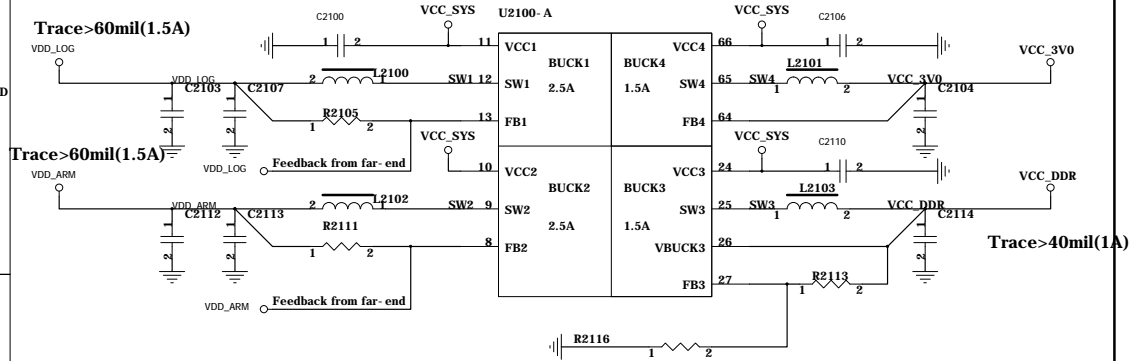

DDR Type	VCC_DDR Voltage	R2113	R2116
DDR4	1.25V	68K	120K
LPDDR3	1.25V	68K	120K
DDR3	1.55V	110K	120K
DDR3L	1.38V	82K	120K

PMIC RK817- 1 LDO

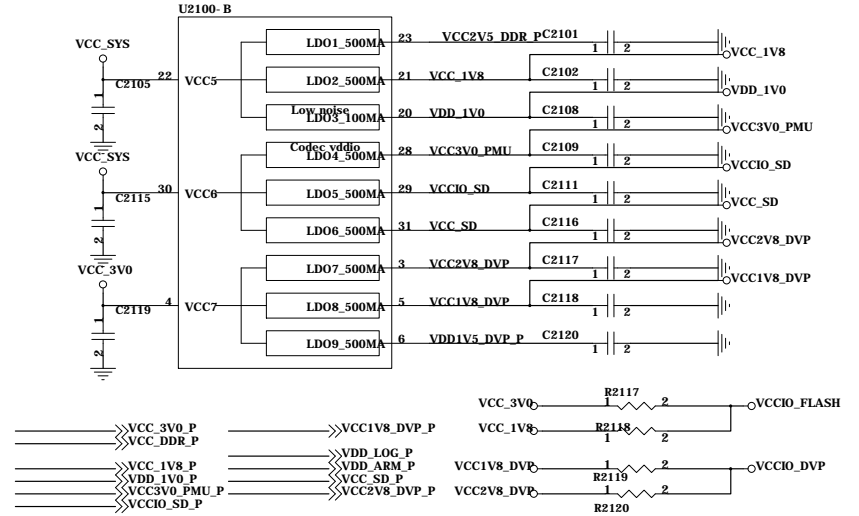

PMIC RK817- 1 Managerment

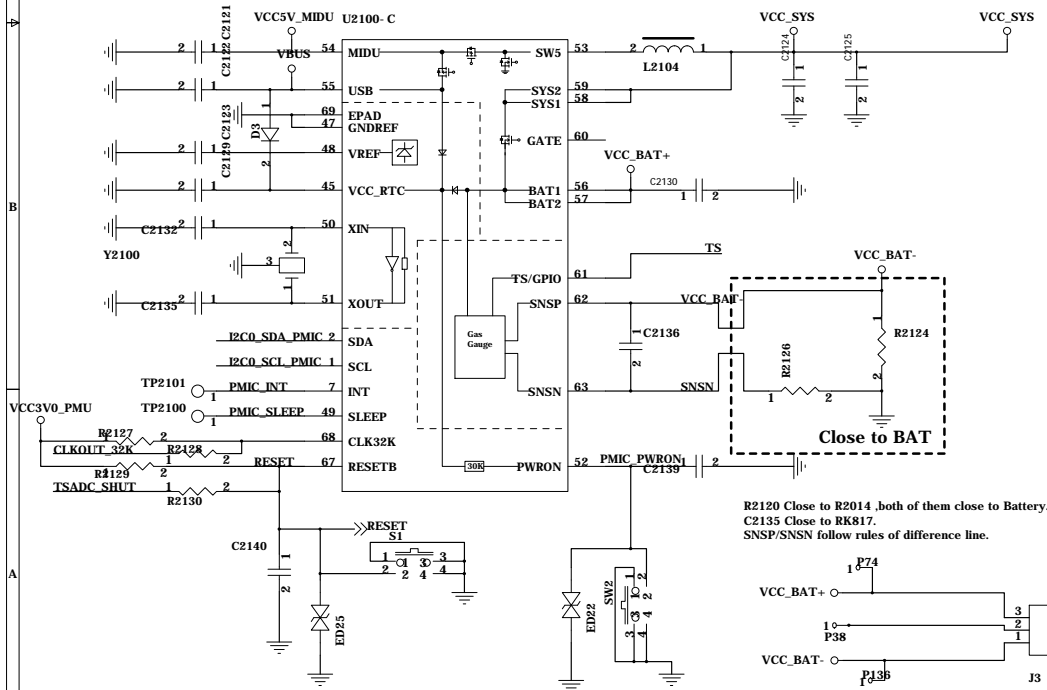

R2120 Close to R2014 ,both of them close to Battery.
 C2135 Close to RK817.
 SNSP/SNSN follow rules of difference line.

PMIC RK817- 1 CODEC

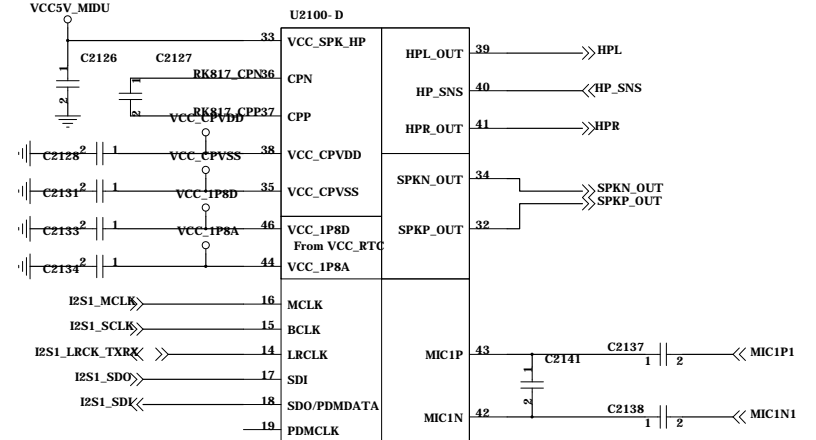

Project:			
File:			
Date:	Tuesday, January 02, 2018	Rev:	V0.1
Designed by:	Linus	Sheet:	11 of 99

USB Port

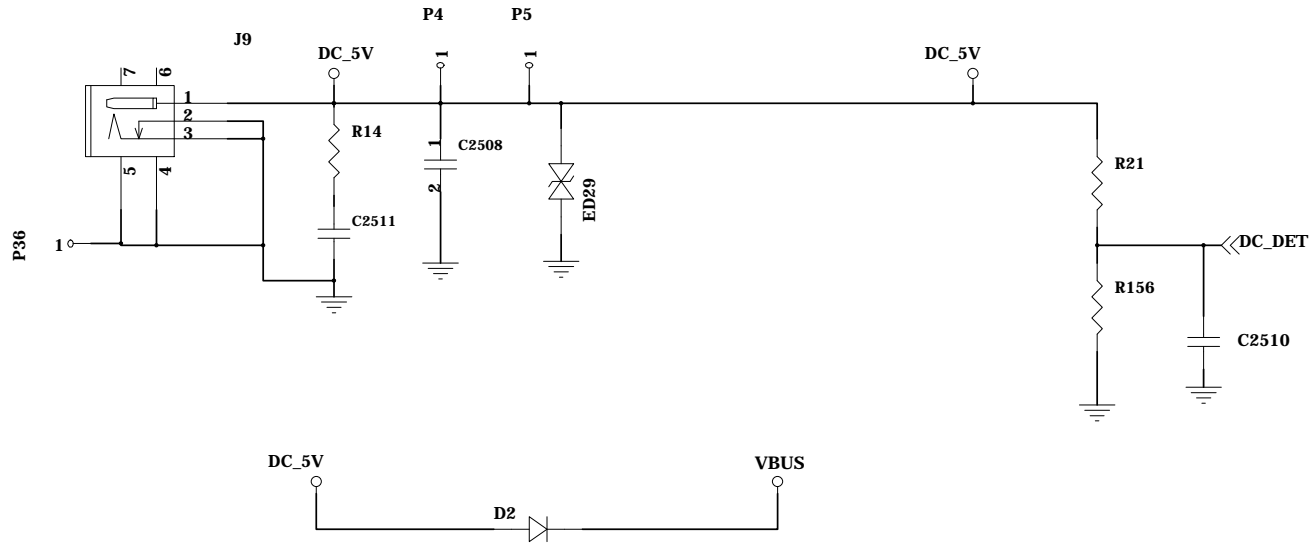
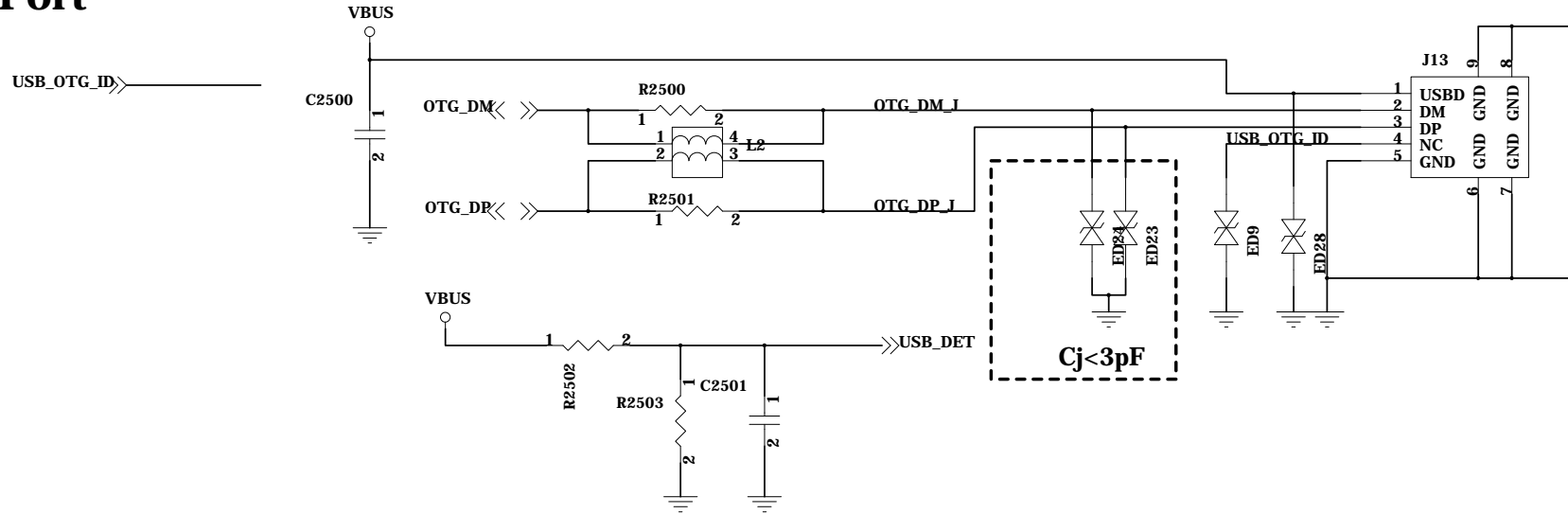

Project:			
File:			
Date:	Tuesday, January 02, 2018	Rev:	V0.1
Designed by:	Linus	Sheet:	11 of 99

DDR3 4x4bit

Note: The simulation frequency of the template is 456MHz.
Remind: Refer to the latest AVL for parts selection.

4X4bit DDR3

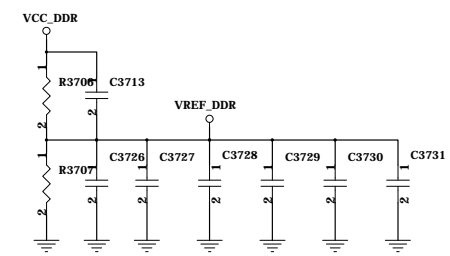
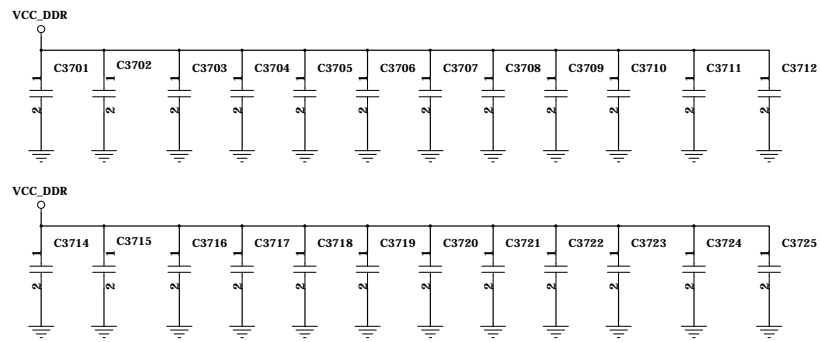
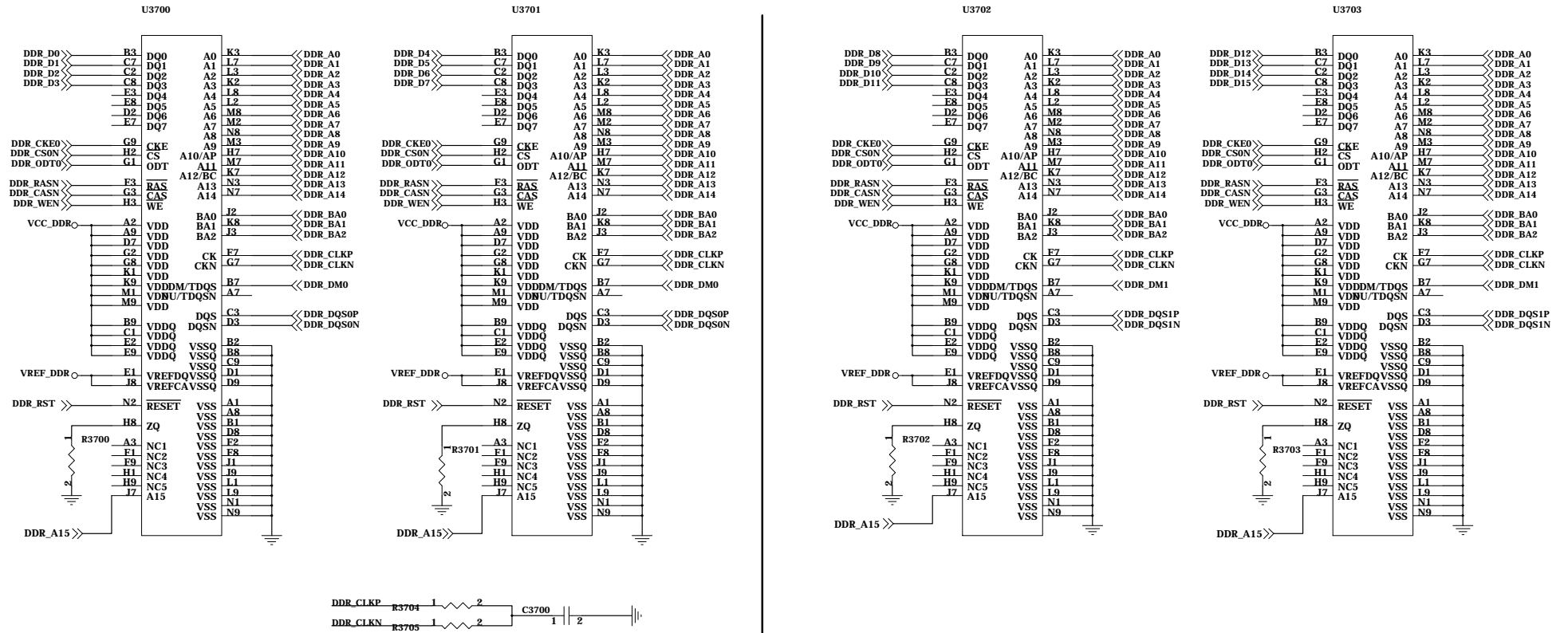

Project:			
File:	RAM DDR3 4x16bit		
Date:	Tuesday, March 13, 2018	Rev:	V1.0
Designed by:	Zhangdz	Sheet:	11 of 99

Nand Flash

Remind: Refer to the latest AVL for parts selection.

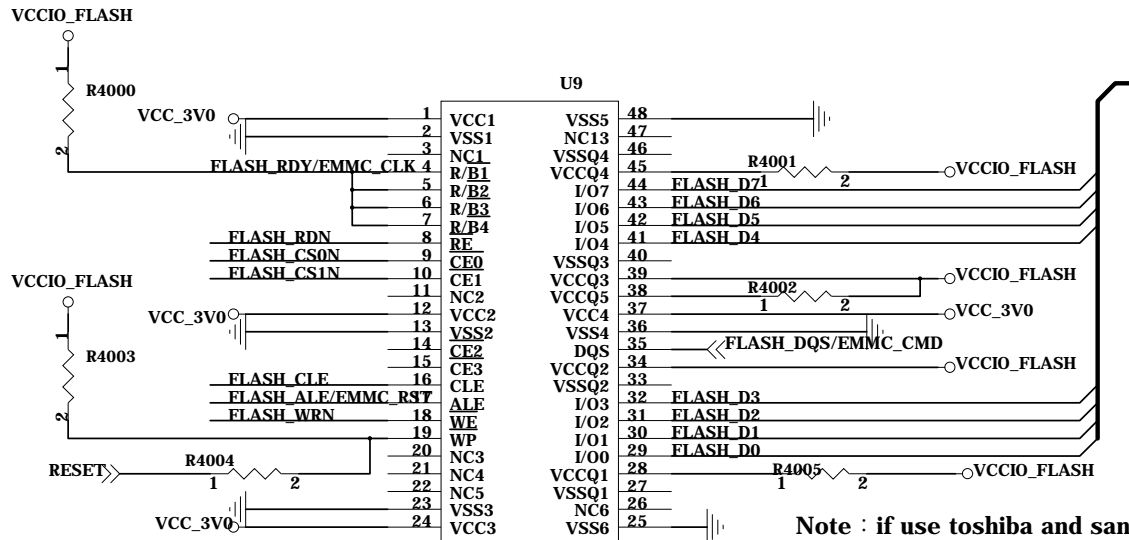
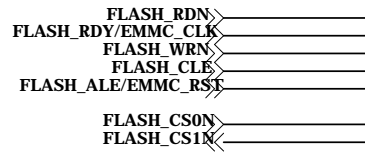

Note : if use toshiba and sandisk DDR mode, VCCQ1 and VCCQ4 must be connected to VCC_IO.

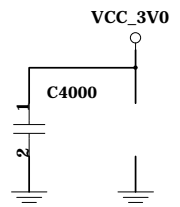

Project:			
File:			
Date:	Tuesday, January 02, 2018	Rev:	V0.1
Designed by:	Linus	Sheet:	11 of 99

eMMC Flash

Remind: Refer to the latest AVL for parts selection.

FLASH_RDY/EMMC_CLK
FLASH_ALE/EMMC_RST

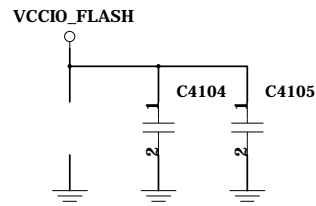
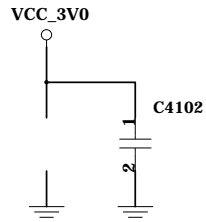
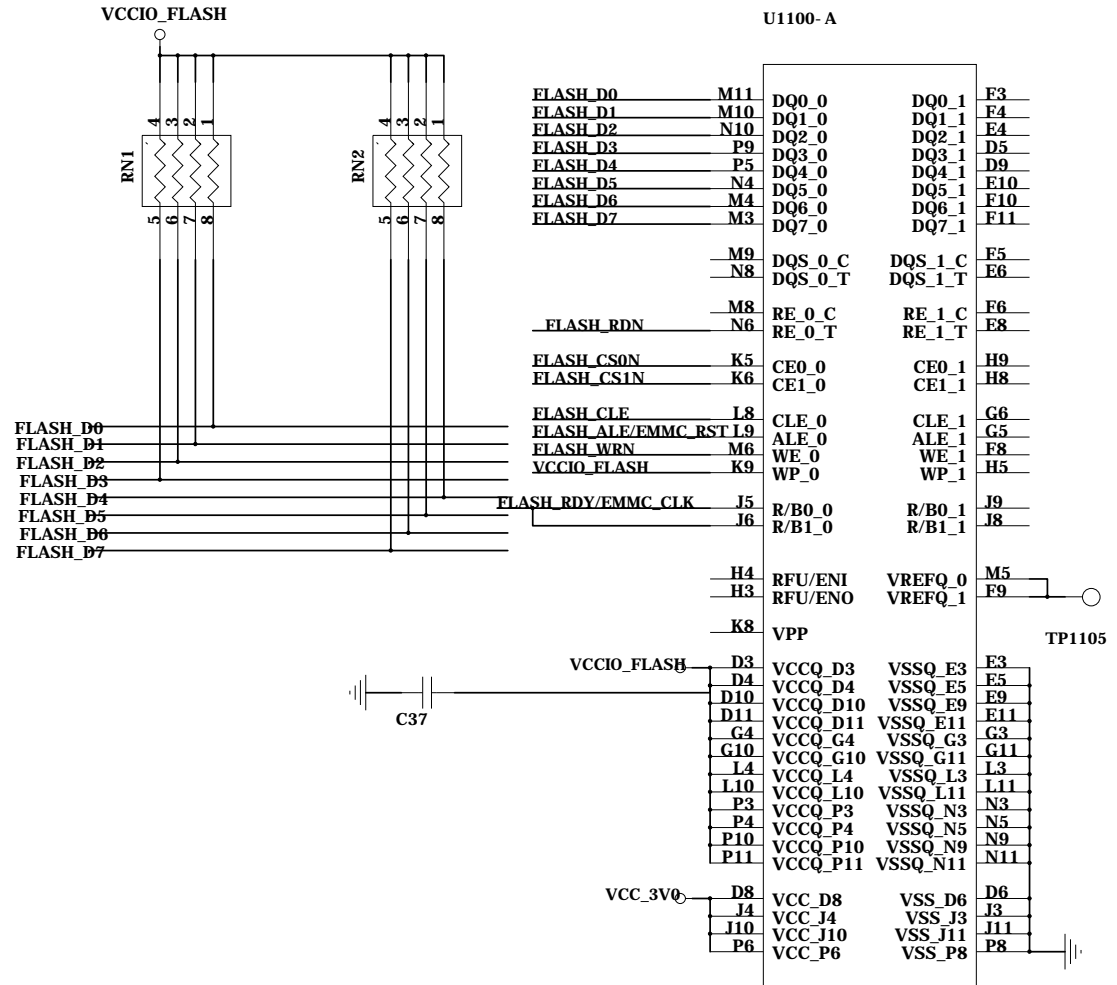
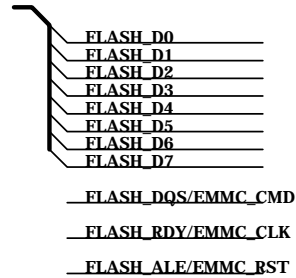
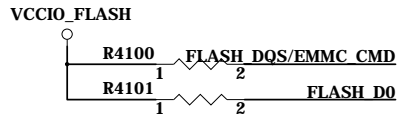

Project:			
File:			
Date:	Tuesday, January 02, 2018	Rev:	V0.1
Designed by:	Linus	Sheet:	11 of 99

MIPI Camera

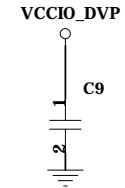
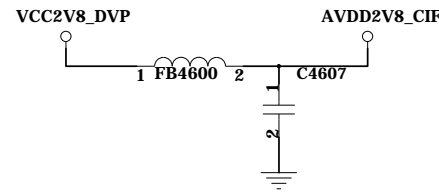
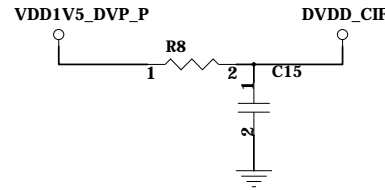
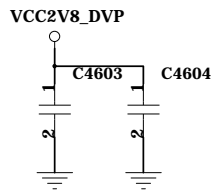
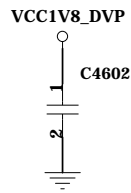
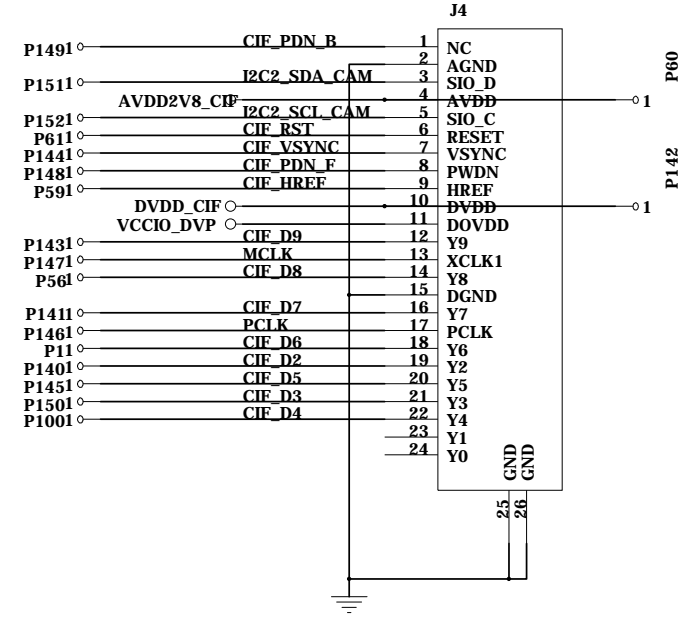
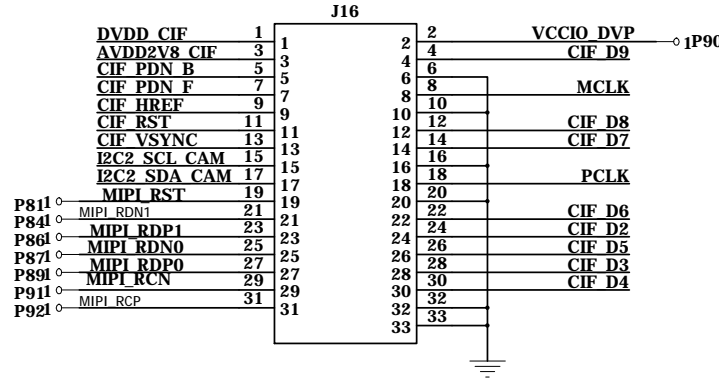
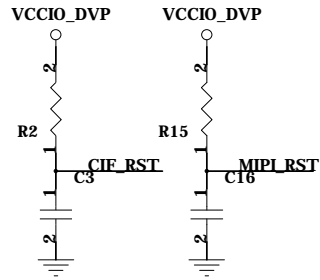
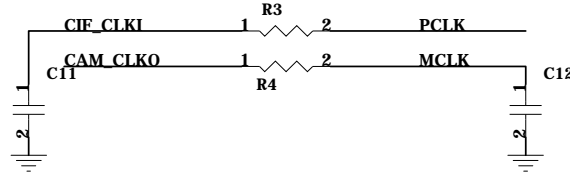
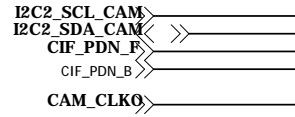

Project:			
File:			
Date:	Tuesday, January 02, 2018	Rev:	V0.1
Designed by:	Linus	Sheet:	11 of 99

E
D
C
B
A

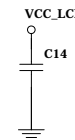
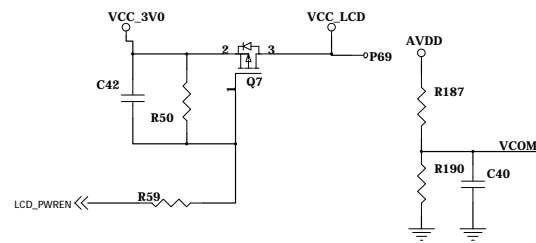
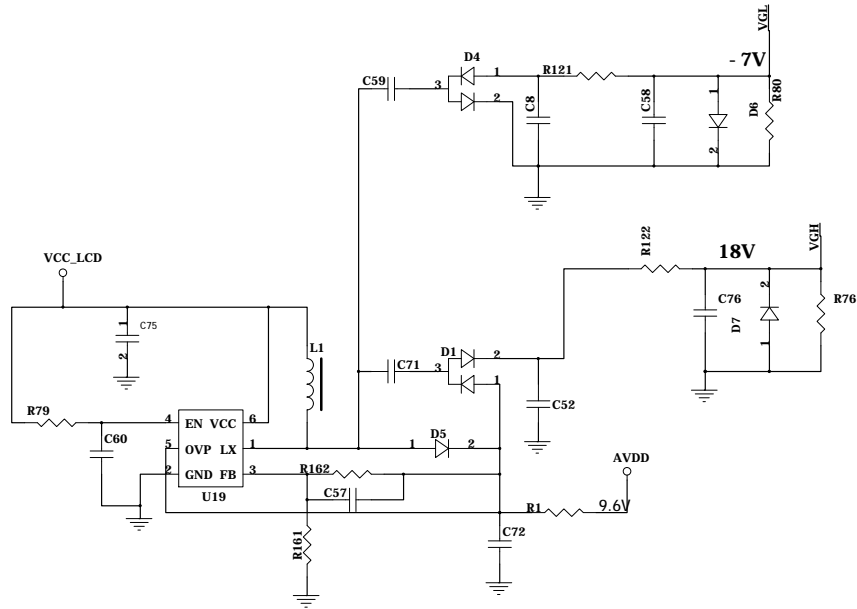
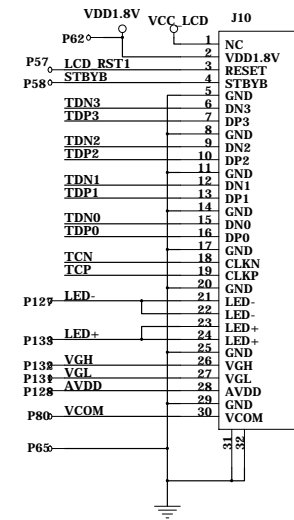
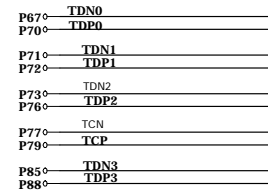
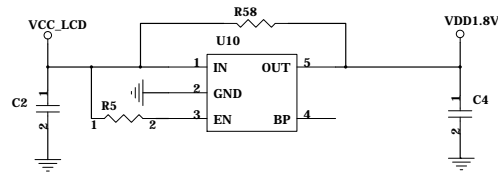
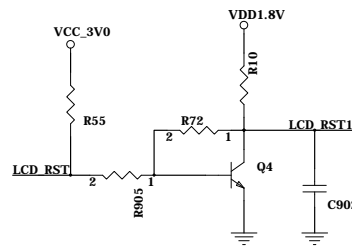
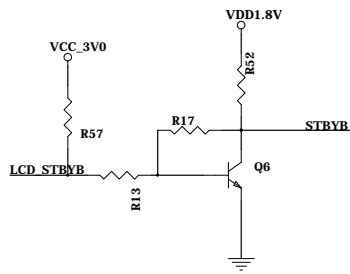
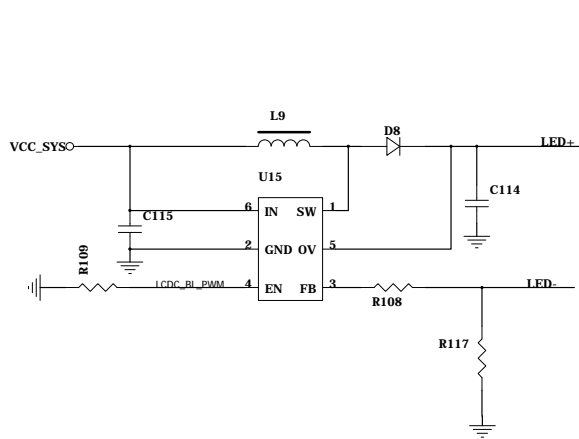

Project:			
File:			
Date:	Tuesday, January 02, 2018	Rev:	V0.1
Designed by:	Linus	Sheet:	11 of 99

WiFi/BT Module

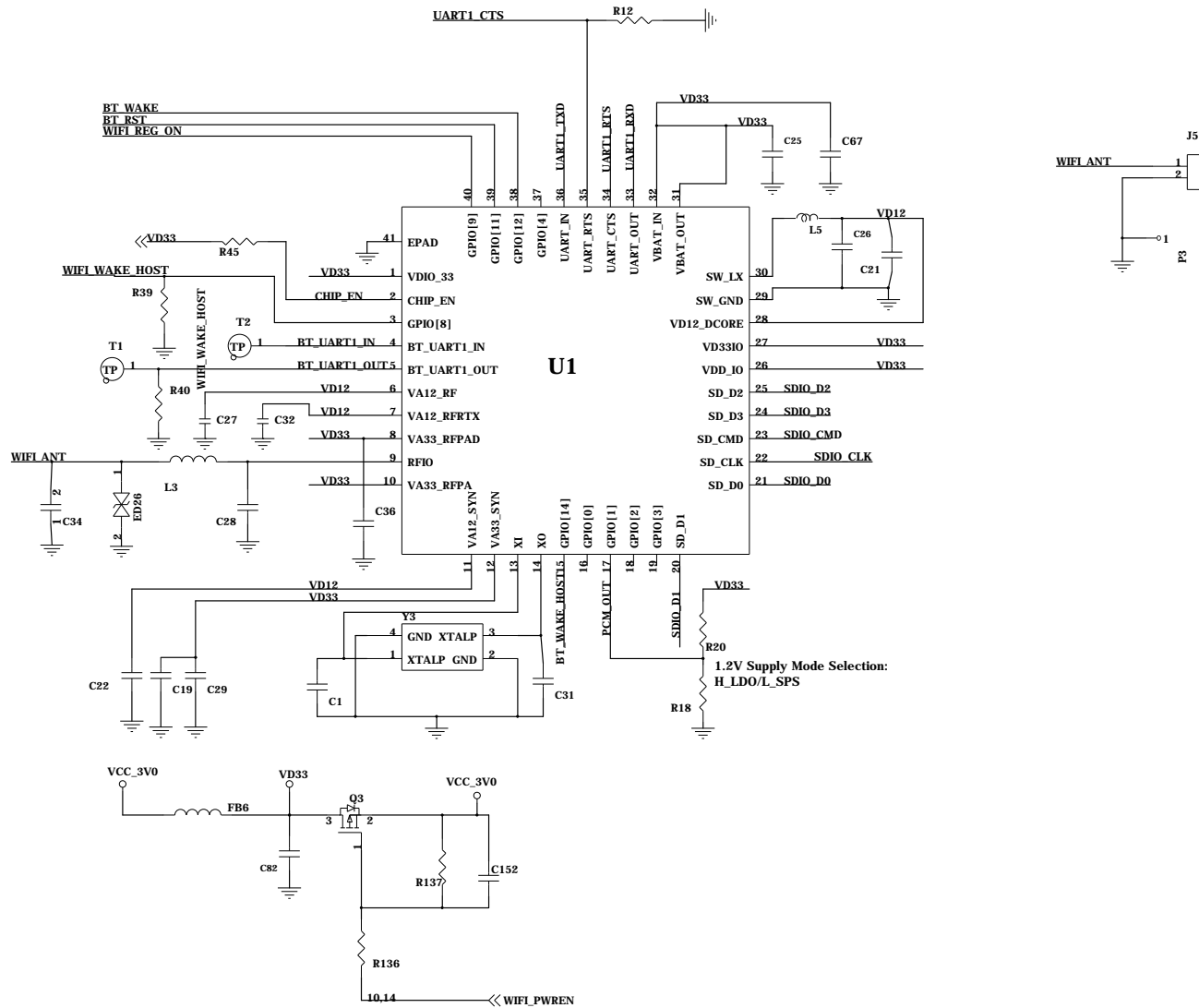

Fuzhou Rockchip Electronics			
Project:			
File:			
Date:	Tuesday, January 02, 2018	Rev:	V0.1
Designed by:	Linus	Sheet:	11 of 99

Headphone

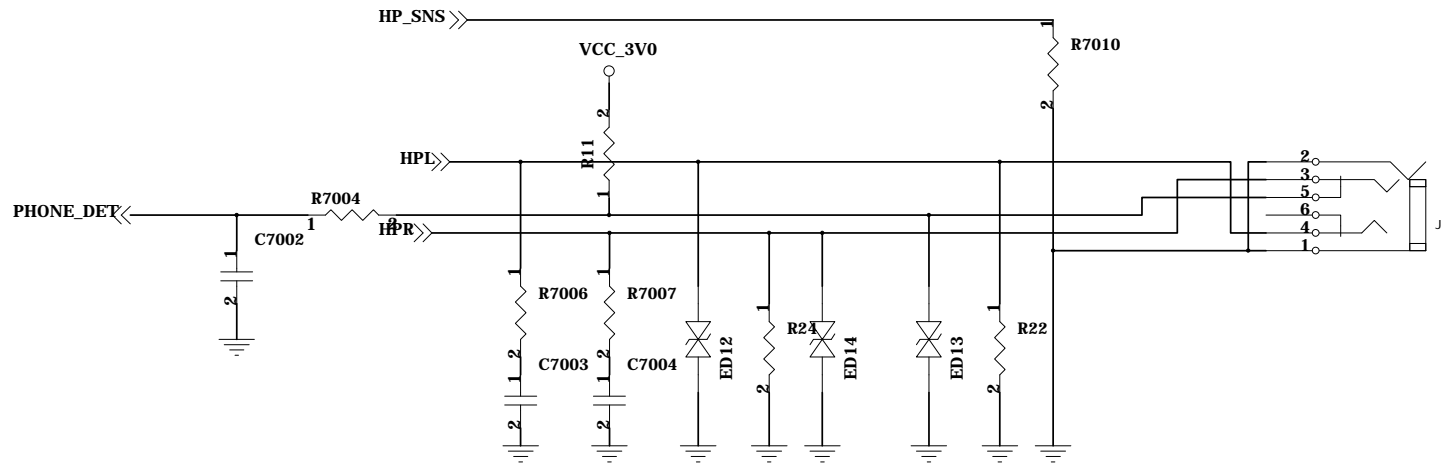

Microphone

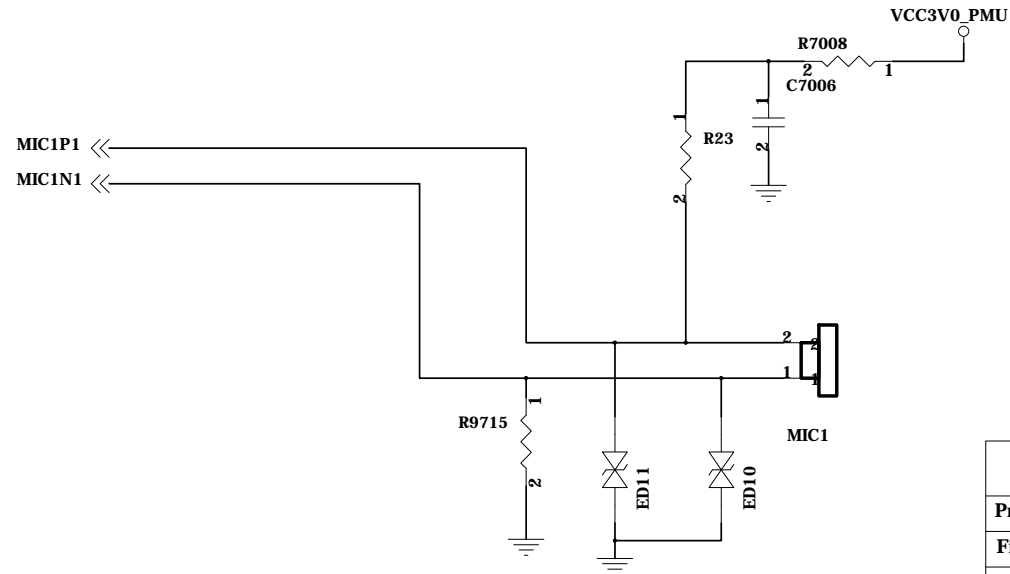

Project:			
File:			
Date:	Tuesday, January 02, 2018	Rev:	V0.1
Designed by:	Linus	Sheet:	11 of 99

TP_INT
I2C1_SDA
I2C1_SCL
TP_RST

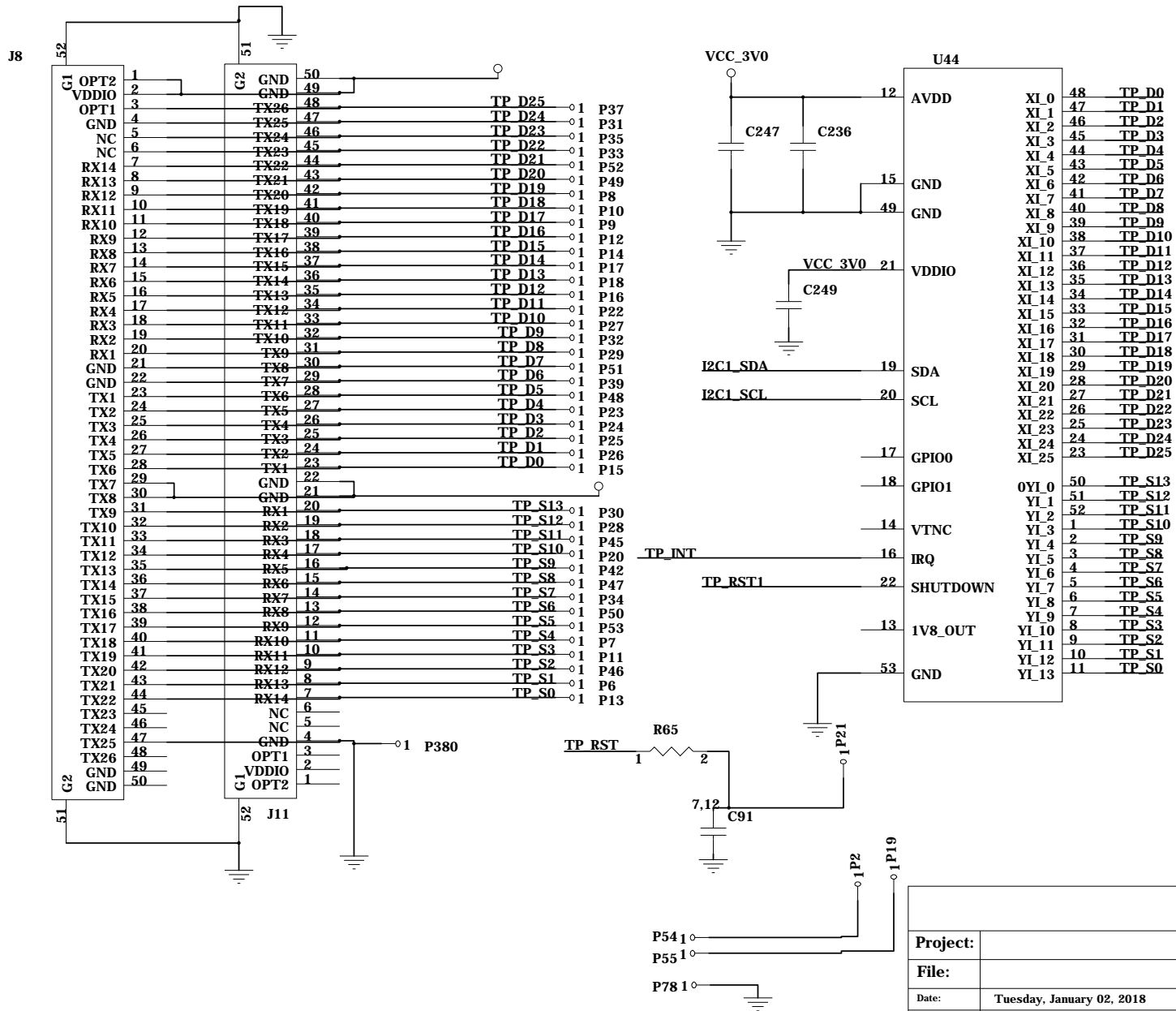

Project:			
File:			
Date:	Tuesday, January 02, 2018	Rev:	V0.1
Designed by:	Linus	Sheet:	11 of 99

G- sensor

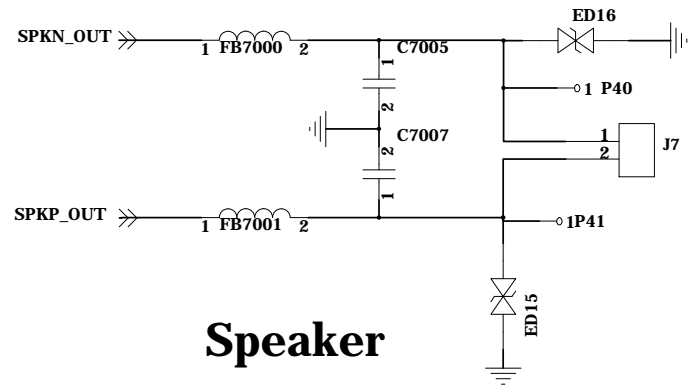
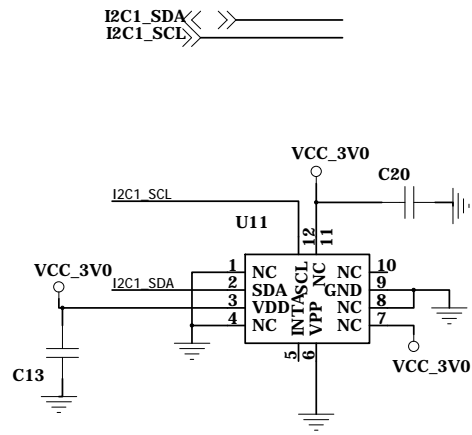

Speaker

Project:			
File:			
Date:	Tuesday, January 02, 2018	Rev:	V0.1
Designed by:	Linus	Sheet:	11 of 99

TF Card

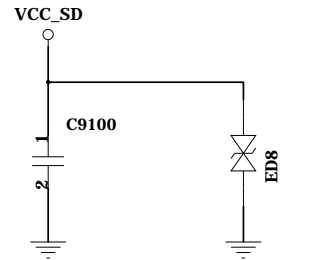
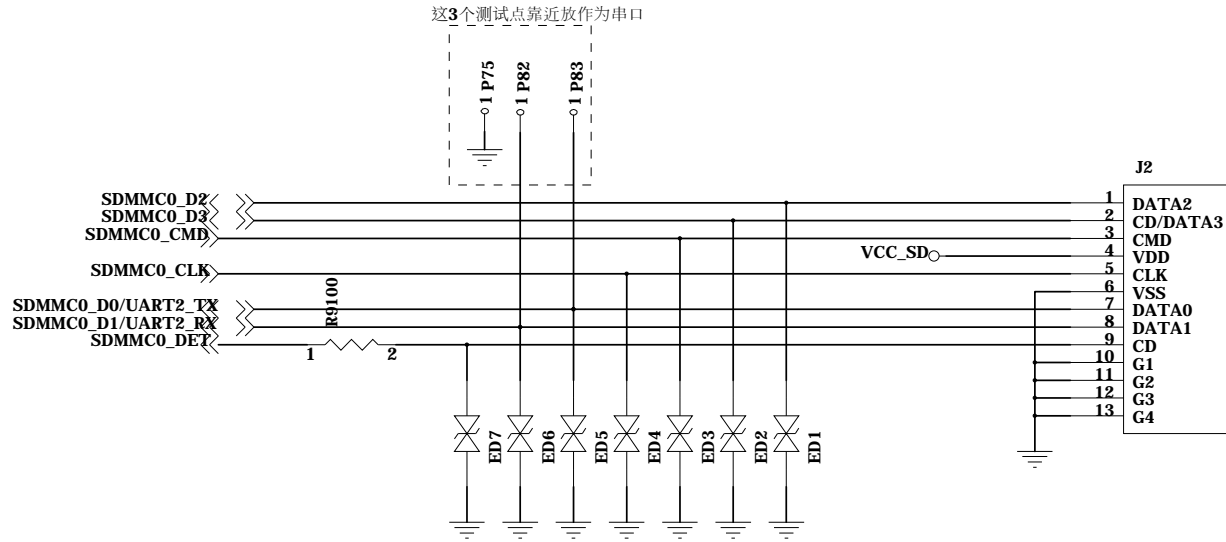

Close to TF Connector

Project:			
File:			
Date:	Tuesday, January 02, 2018	Rev:	V0.1
Designed by:	Linus	Sheet:	11 of 99

KEY BAORD

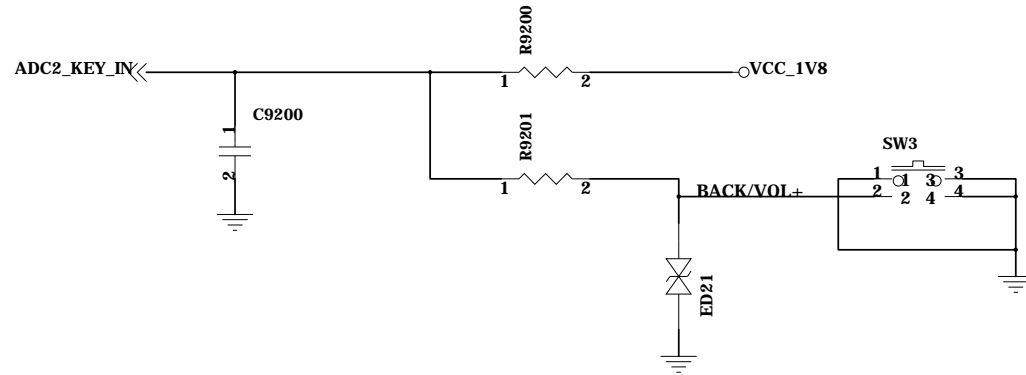

Key Name	SARADC
VOL+/RECOVERY	10
VOL-	170

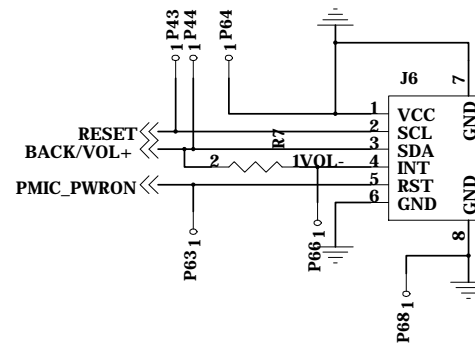
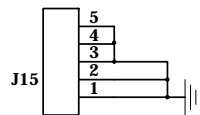
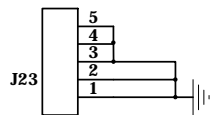
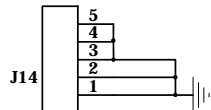
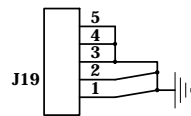
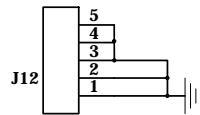
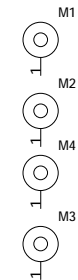

Project:			
File:			
Date:	Tuesday, January 02, 2018	Rev:	V0.1
Designed by:	Linus	Sheet:	11 of 99