

# Qilive



## Refrigerator-Freezer

600129623/600129804/HD-348RN(JN)

Rated voltage	220 - 240 V~
Rated frequency	50 Hz
Rated current	1 A
Compressor	PZ65H1Z
Lamp Rated Power	2W
Energy consumption	204 kWh/a
Energy consumption E32	0.900kWh/24h
Total volume	262 L
Fresh food compartment Volume	197 L
Four-star compartment Volume	65 L
Climate classification	N/ST
Classification of protection against electric shock Class	I
Refrigerant and inject amount	R600a/81g
Net weight	46.5 kg
Freezing Capacity	3 kg/24h
Temperature rise value	10h
Insulation Blowing Agent	Cyclopentane

### SCHEMA ELECTRIQUE

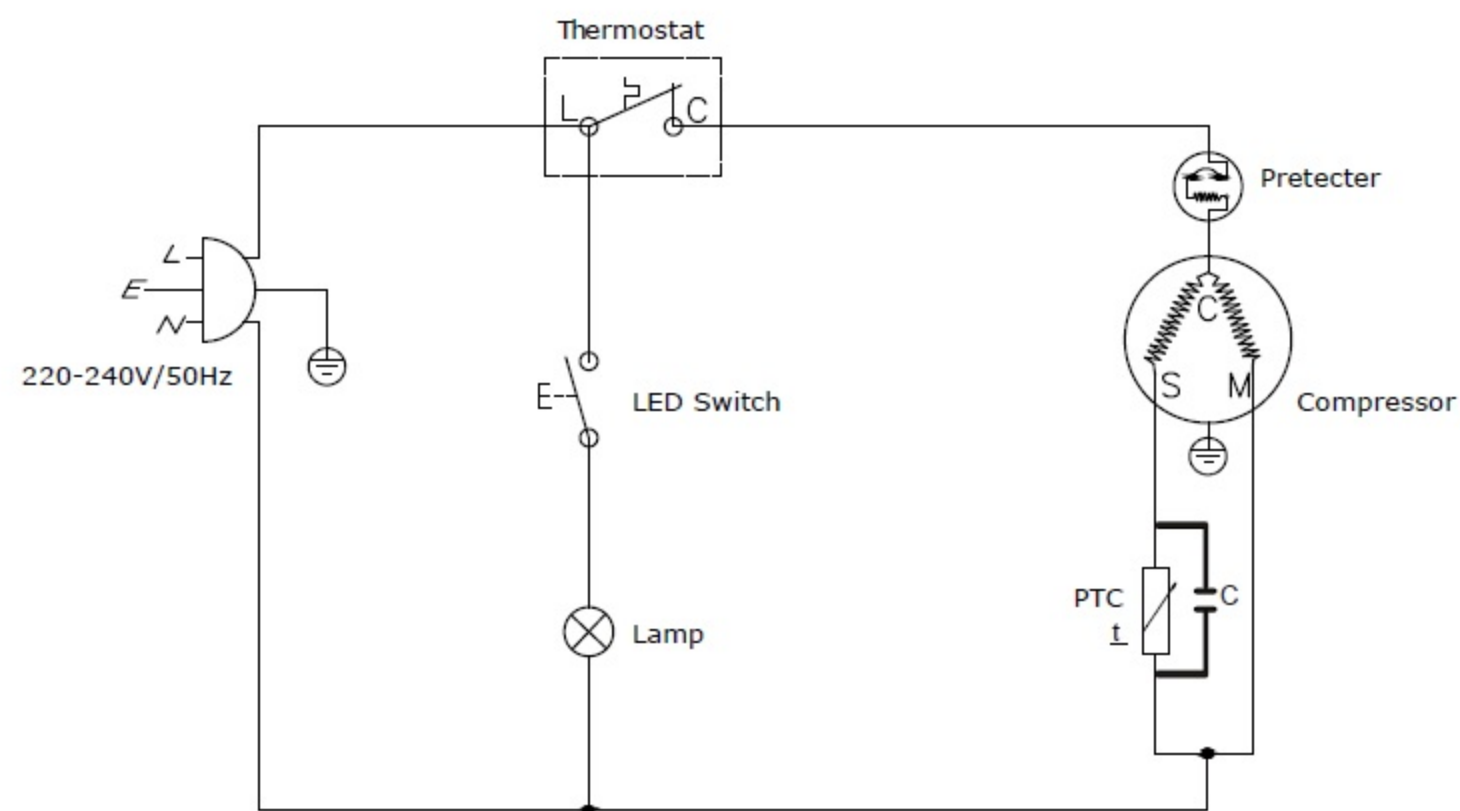

SAS OIA, 200, rue de la Recherche, Le Colibri BP 169,  
59650 Villeneuve d'Ascq, France  
[www.auchan-retail.com/contact](http://www.auchan-retail.com/contact)  
Made in China/Сделано в Китае  
SN : 220369384000001