

OCEANIC OCEAHS90LED

VUE GENERALE

POS	DESIGNATION	REFERENCE	QTE
1	FIXATION DE CONDUIT SUP.	B232501029P	1
2	CONDUIT SUPERIEUR 500mm	B202102036P	1
3	CONDUIT INFERIEUR 500mm	B202102008P	1
4	FIXATION DE CONDUIT INF.	B232501031P	1
5	CORDON D'ALIMENTATION	B6222010230	1
6	BOITIER DE PLATINE	B3025010340	1
7	PLATINE DE PUISSANCE	B6325010020	1
8	GAINES DE CABLAGE PLATINE	B3025010350	1
9	GAINES DE CABLAGE MOTEUR	B3022010680	1
10	CONDENSATEUR 6mf	B6423010240	1
11	SUPPORT BOITIER PLATINE	B3025010250	1
12	BUSE DE SORTIE	B3025020150	1
13	PLAQUE DE FIXATION	B232201012P	1
14	CABLAGE DE LAMPE	B6228020080	1
15	CABLAGE CLAVIER / PLATINE	B6226020230	1
16	PLAFONNIER	B202102019P	1
17	ECLAIRAGE LED	B6224012250	2
18	FILTRE ALUMINIUM	B3528020210	3
19	CLAVIER DE COMMANDE	B764102007B	1
20	SUPPORT DE CLAVIER	B232102103P	1
21	FILTRE CHARBON	B3525010140	2
22	MOTEUR COMPLET	B764102025B	1
23	TABLIER	F3021020010	1

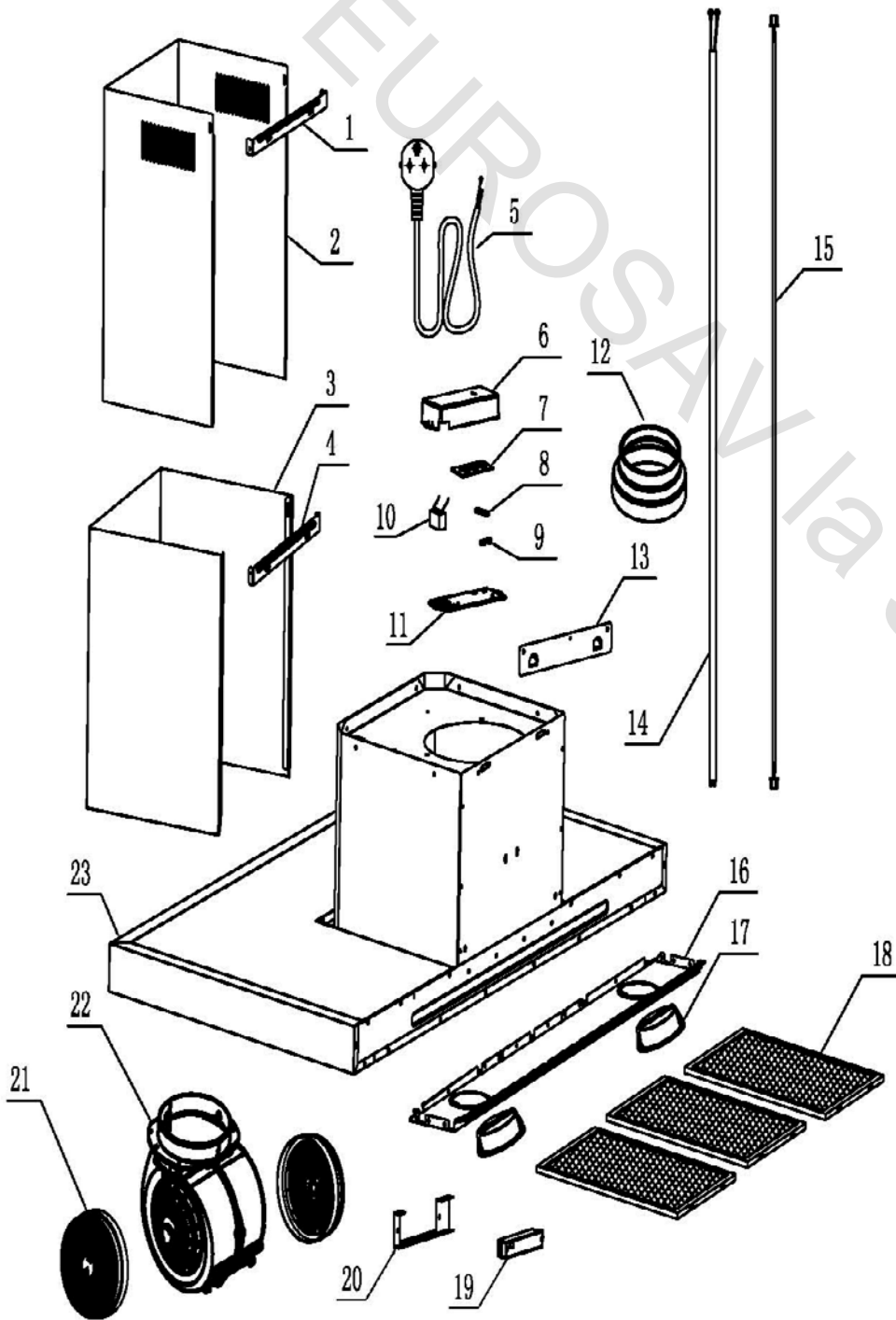

For motor accessory :

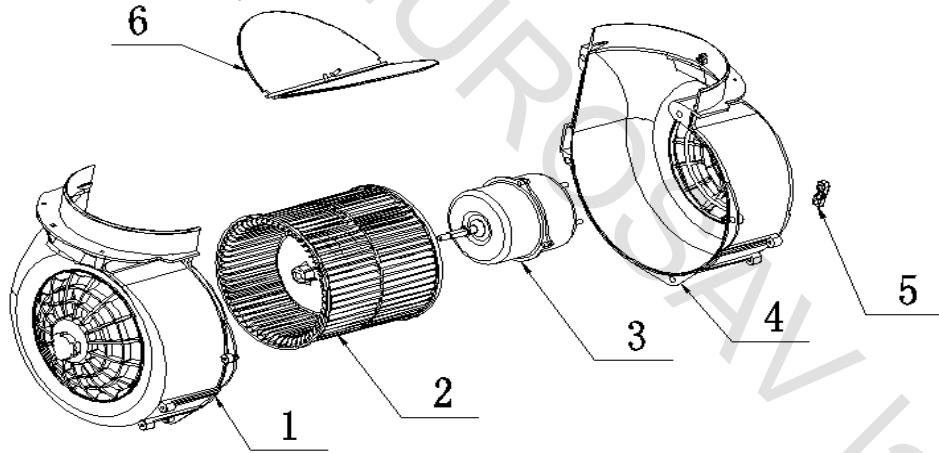

VUE MOTEUR

1	CARTER MOTEUR GAUCHE	B3023010120	1
2	TURBINE DE VENTILATION	B3023010140	1
3	MOTEUR nu	B6124013110	1
4	CARTER MOTEUR DROIT	B3023010130	1
5	GAINÉ DE CABLAGE	B3022010680	1
6	CLAPET ANTI-RETOUR	B3022010220	2