

APPLIANCE NAME:
FALCON KITCHENER 90 DF FSD

DSL0321 P00
DATE 11.08.06 ISSUE STATUS 001



ALL MODELS

DSL0321 P01
DATE 11.08.06 ISSUE STATUS 001

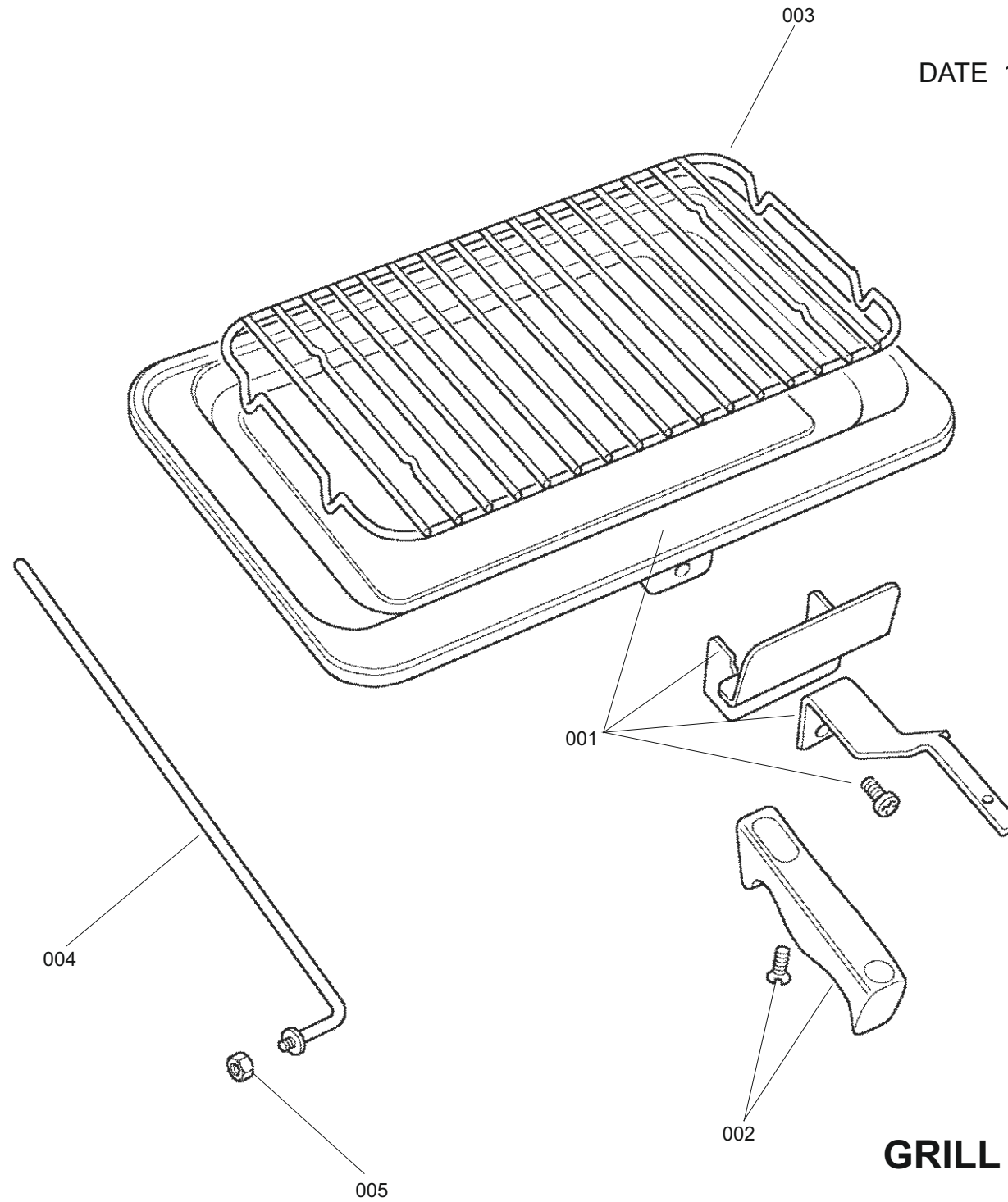

GRILL PAN

ALL MODELS

DSL0321 P02
DATE 11.08.06 ISSUE STATUS 001

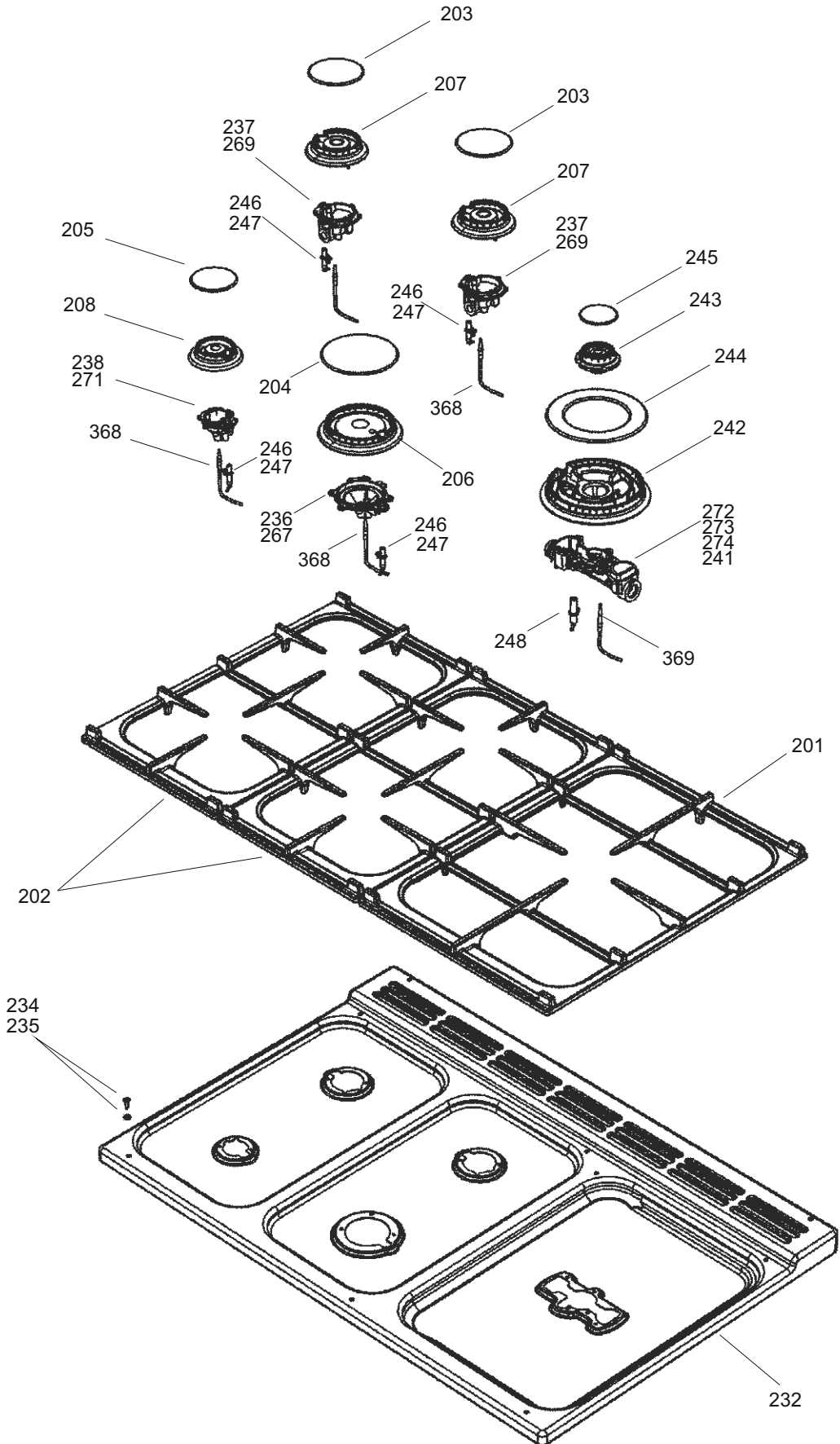

PAN SUPPORTS BURNERS & HOTPLATE ASSEMBLY

ALL MODELS

DSL0321 P03
DATE 29.06.09 ISSUE STATUS 002

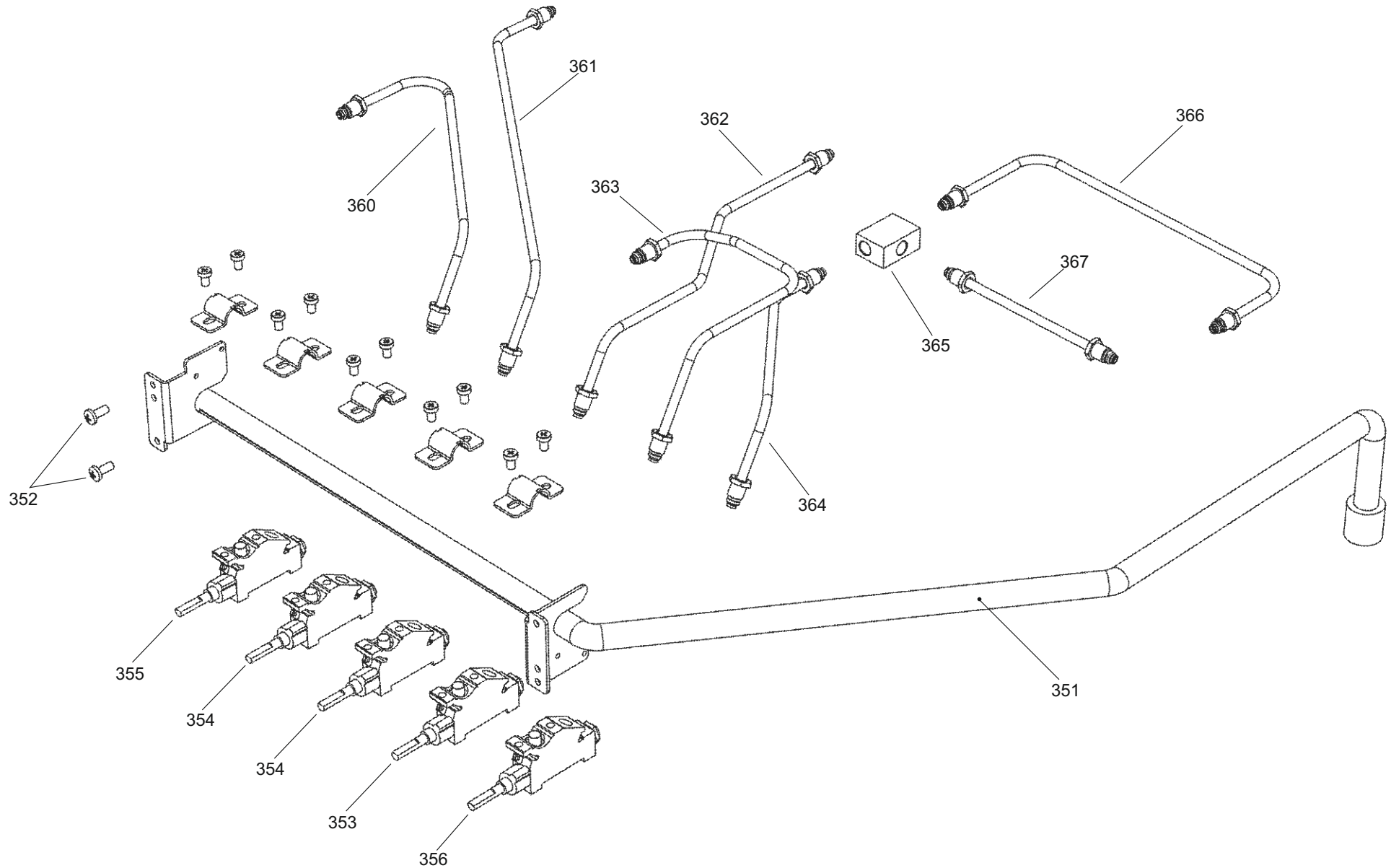

GAS RAIL - TAPS - INJECTORS AND PIPES

ALL MODELS

DSL0321 P04
DATE 11.08.06 ISSUE STATUS 001

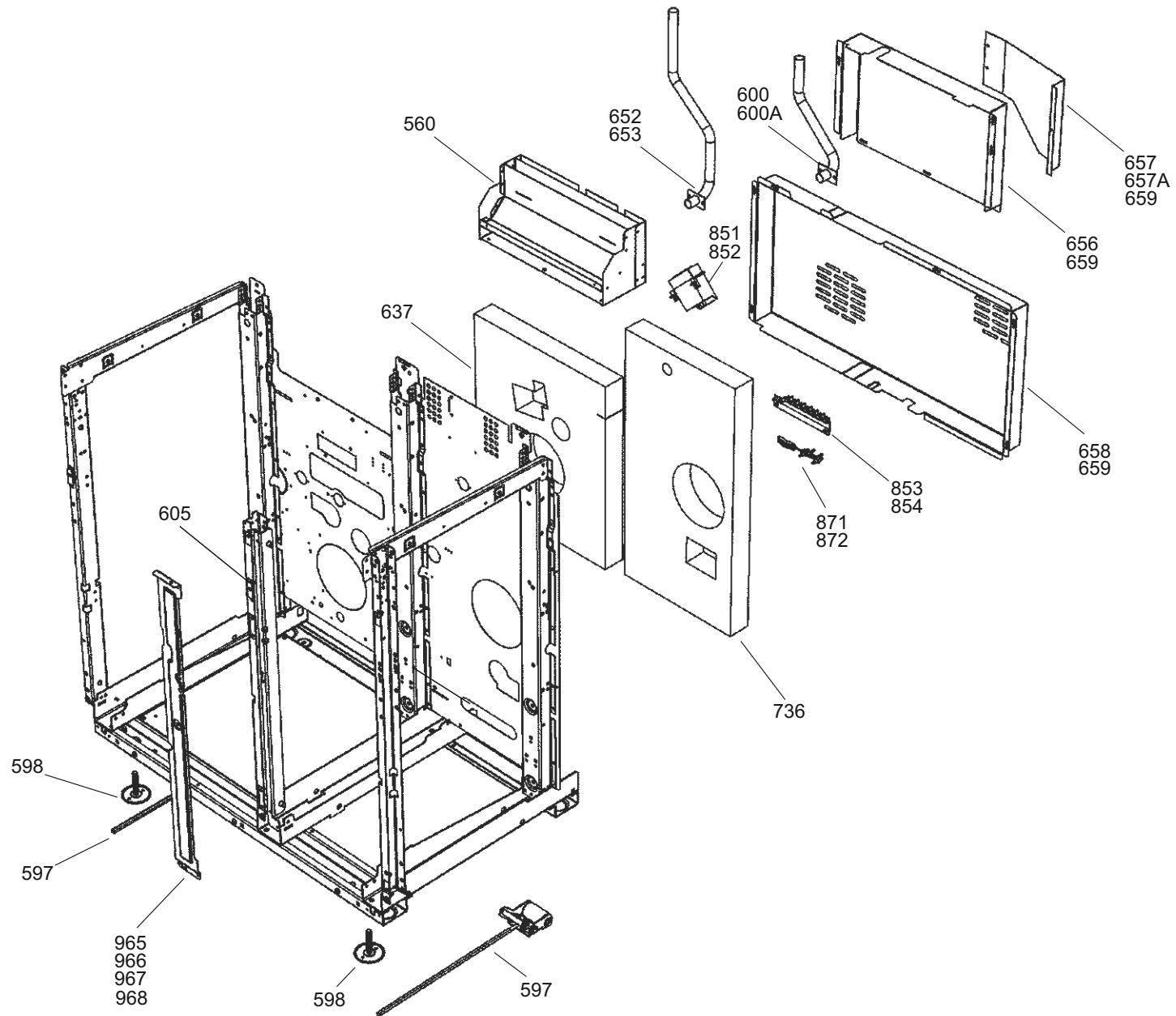

CHASSIS AND FRAME ASSEMBLY

ALL MODELS

DSL0321 P05

DATE 11.08.06 ISSUE STATUS 001

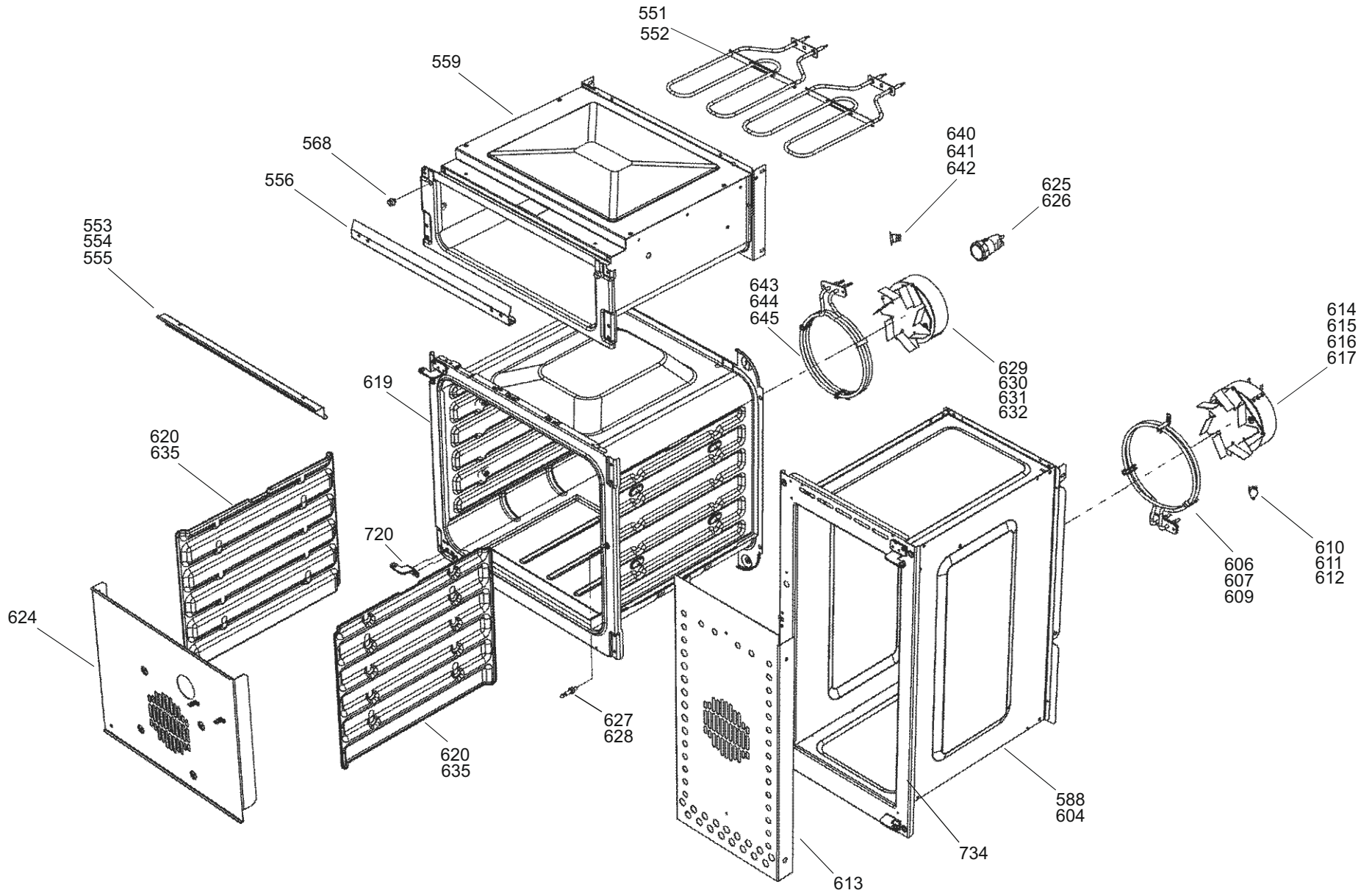

LH OVEN - RH OVEN AND GRILL CHAMBER

ALL MODELS

DSL0321 P06

DATE 11.08.06 ISSUE STATUS 001

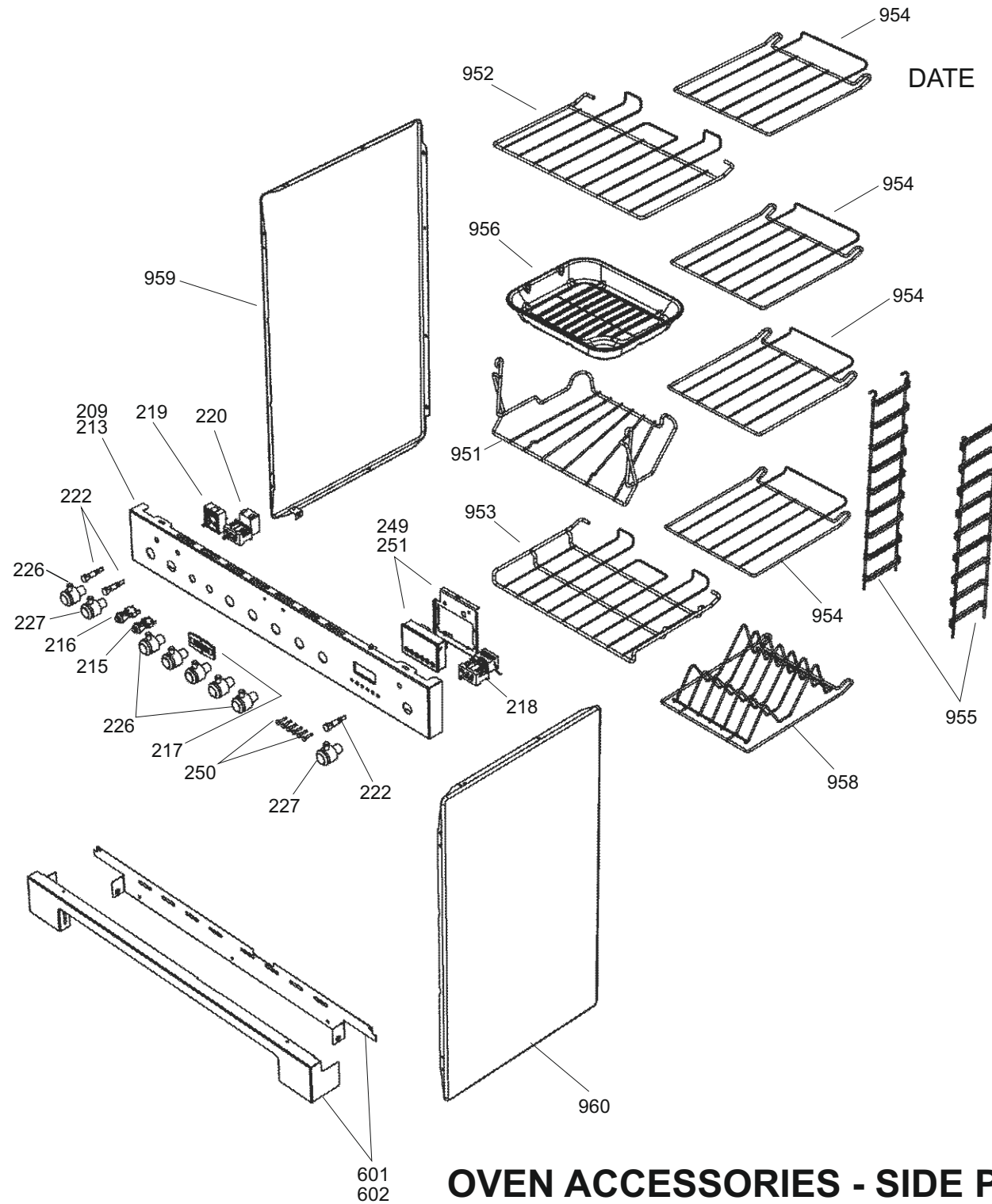

OVEN ACCESSORIES - SIDE PANELS & PLINTHS

ALL MODELS

DSL0321 P07
DATE 11.08.06 ISSUE STATUS 001

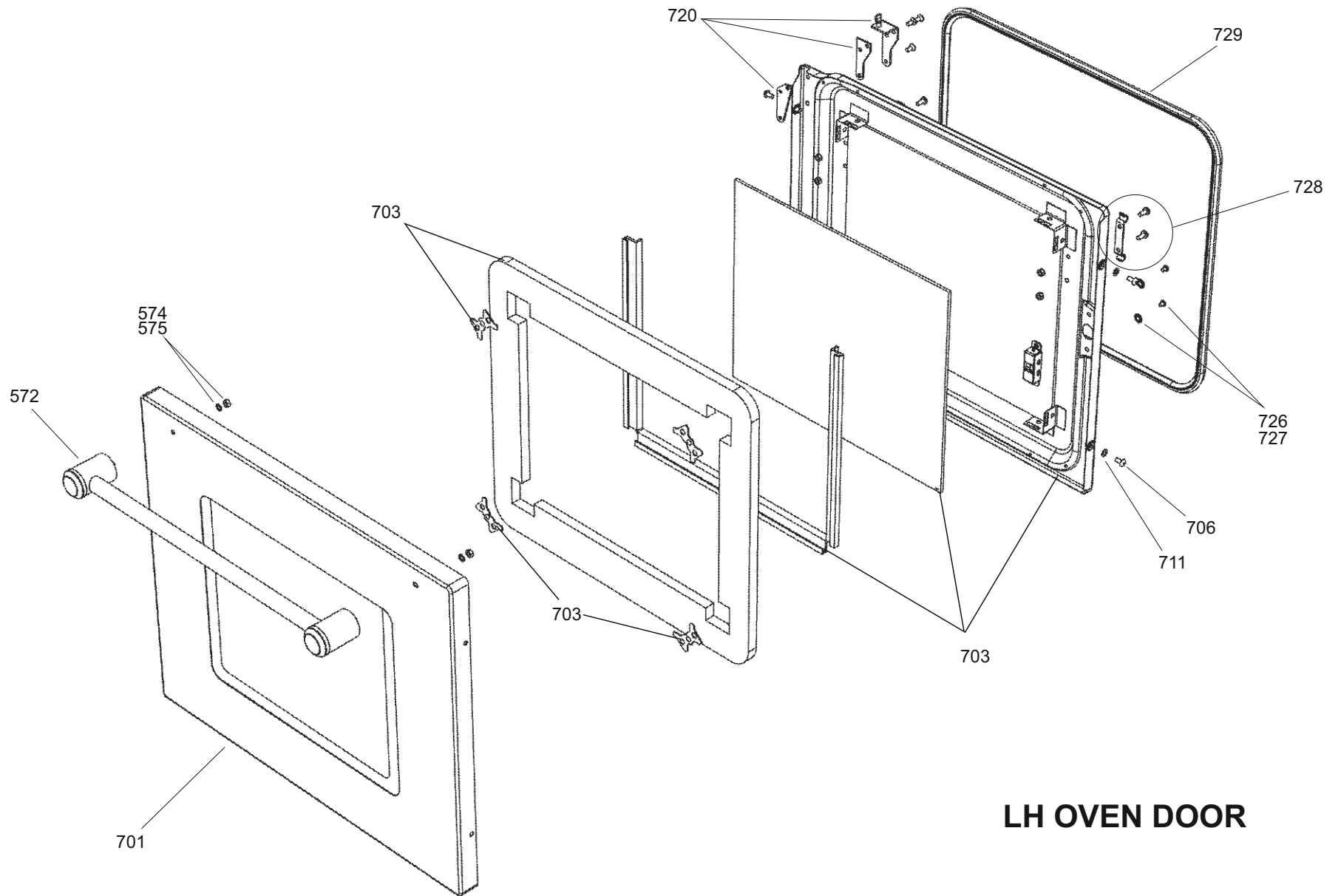

LH OVEN DOOR

ALL MODELS

DSL0321 P08
DATE 11.08.06 ISSUE STATUS 001

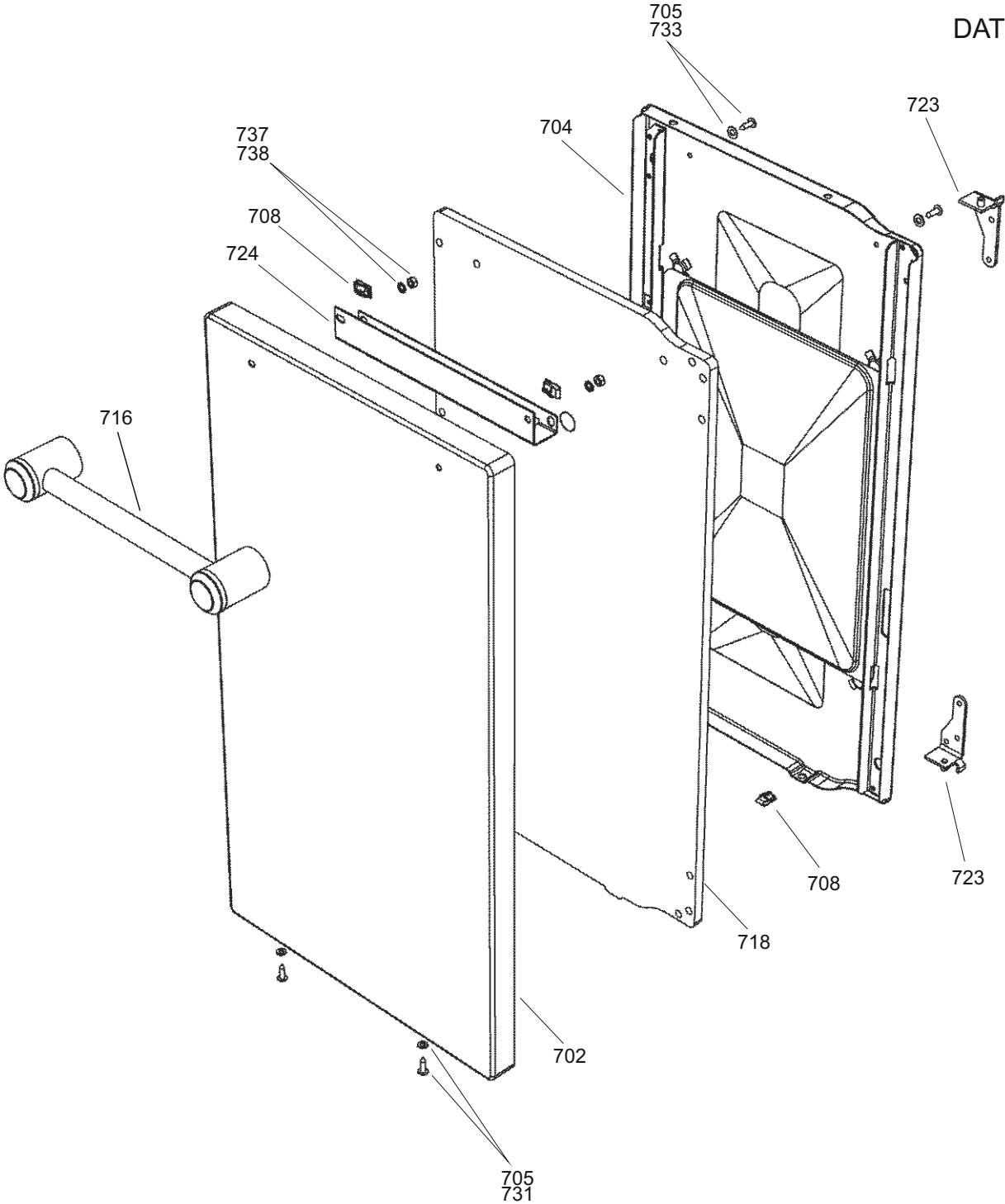

RH OVEN DOOR

FALCON KITCHENER 90 DF

DSL0321 P10

UP TO SERIAL No 9999

DATE 10.11.09 ISSUE STATUS 003

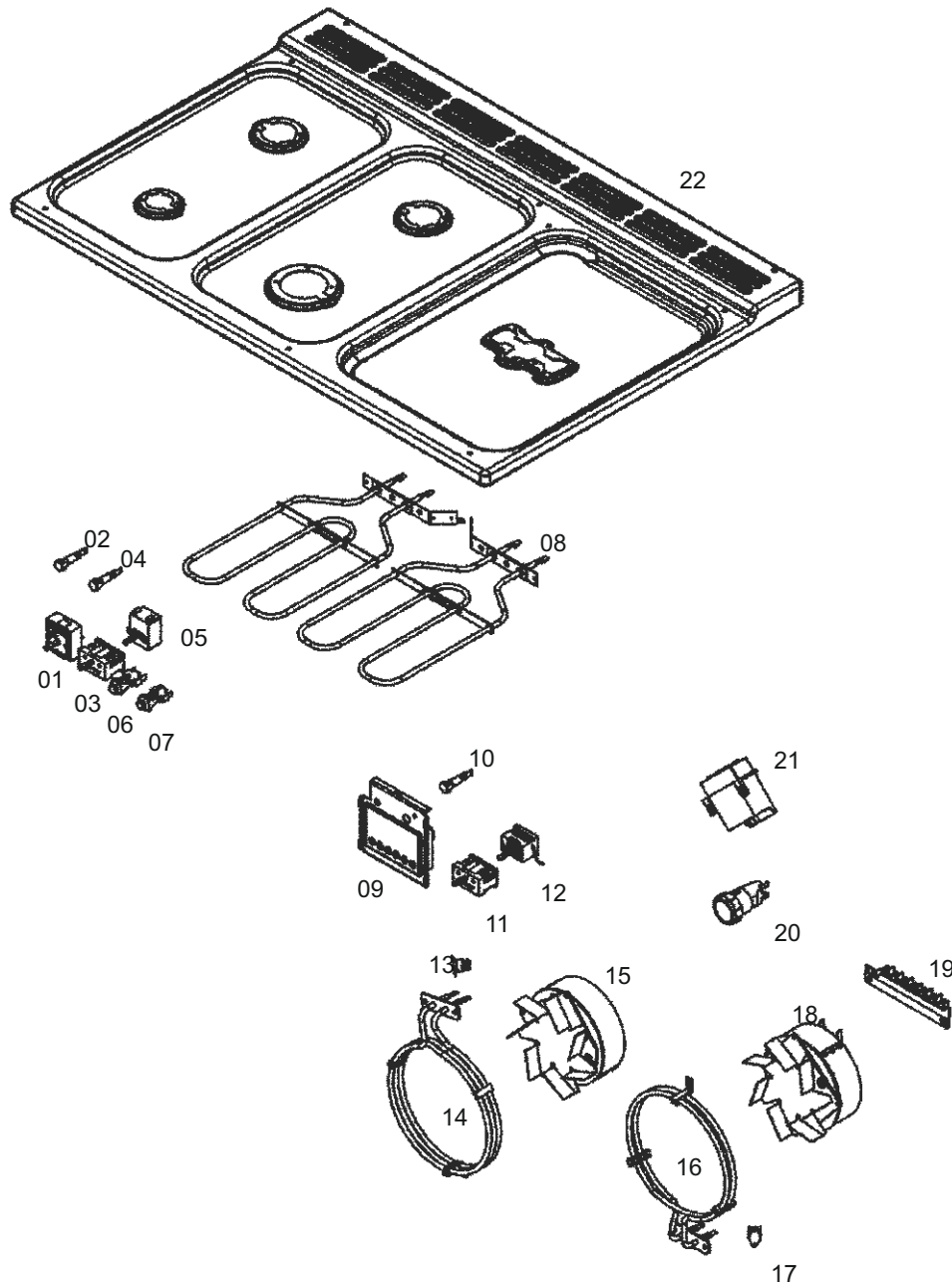

REFS	HARNESS	KITCHENER 110 DF	QTY	COMPONENTS												
				09	10	11	12	16	17	18	19					
865	P040233	RH WIRING HARNESS	1	09	10	11	12	16	17	18	19					
863	A097411	WIRE ASSY - NO.6 GEN - CHASIS (EARTH)	1	21												
857	P035432	HT WIRING HARNESS	1	21												
858	P040234	LT WIRING HARNESS	1	01	02	03	04	05	06	07	09	13	14	15	19	20
856	P095450	WIRE ASSY - LH FAN, ELEMENT, LIGHT (EARTH)	1	14	15	19	20									
864	P027686	WIRE ASSY - LH FAN, GEN BOX, LIGHT, LDV (BLUE RTN)	1	13	15	19	20	21								
859	P027733	WIRE ASSY - RH FAN, BLOCK (BLUE RTN)	1	17	18	19										
862	P027672	WIRE ASSY - RH FAN, ELEMENT, BLOCK (EARTH)	1	16	18	19										
860	A094943	WIRE ASSY - T'STAT, CHASIS (EARTH)	2	05	12											
861	A055374	WIRE ASSY - GRILL, CHASSIS (EARTH)	2	08	19											
866	P040066	WIRE ASSY - LVD LINK RTN	2	13	14	16	17									

WIRING DIAGRAM

FALCON KITCHENER 90 DF DSL0321 P10A

FROM SERIAL No 10000

DATE 10.11.09 ISSUE STATUS 01-

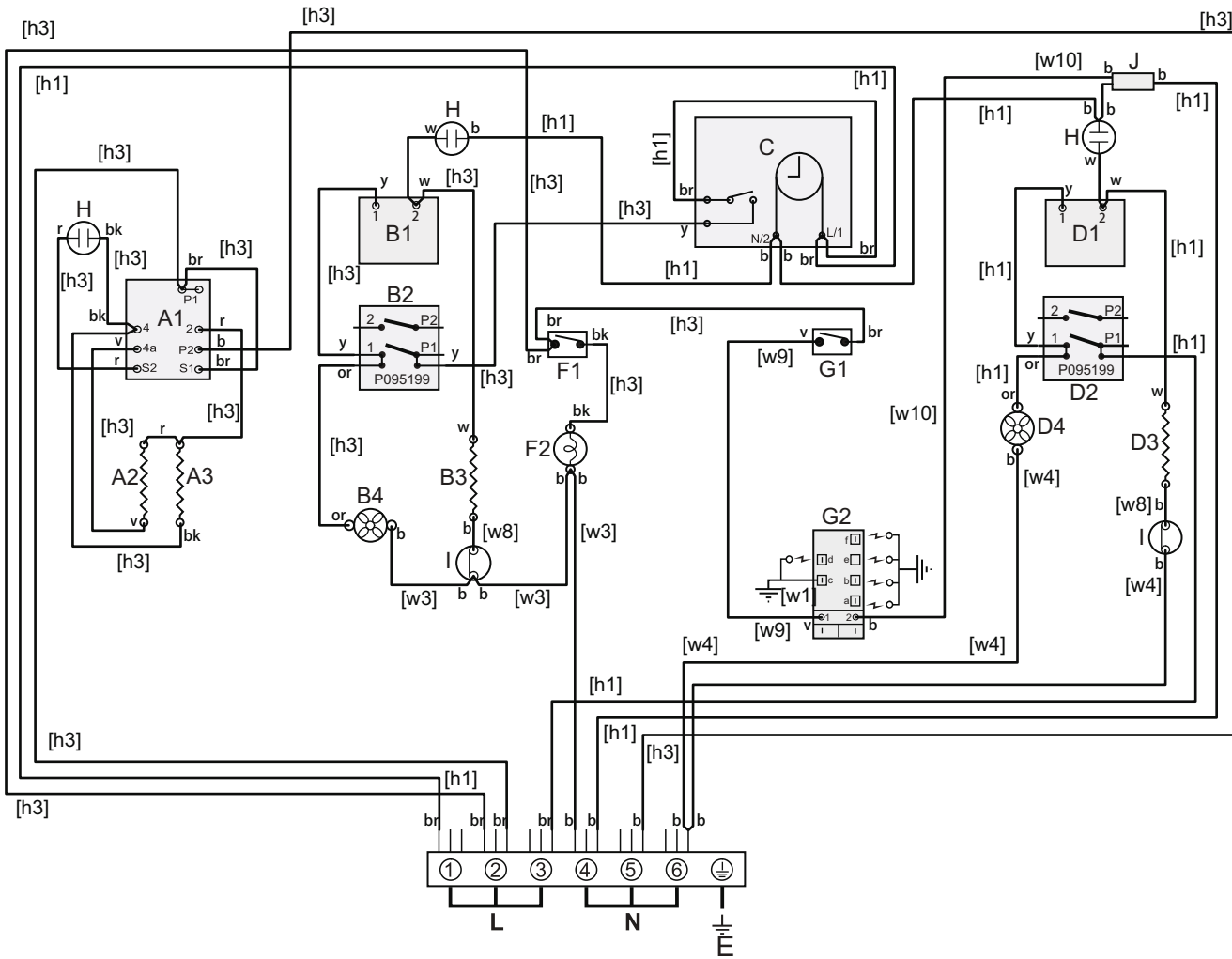

Code	Colour
b	Blue
br	Brown
bk	Black
or	Orange
r	red
v	violet
w	White
y	yellow
gr	Grey

Code	Description
A1	Grill energy regulator
A2	Grill element left hand side
A3	Grill element right hand side
B1	Left hand oven thermostat
B2	Left hand oven switch
B3	Left hand oven element
B4	Left hand oven fan
C	Clock / Oven timer

Code	Description
D1	Right hand thermostat
D2	Right hand oven switch
D3	Right hand oven element
D4	Right hand oven fan
F1	Oven light switch
F2	Oven light
G1	Ignition switch
G2	Ignition spark generator
I	Thermal cut out
J	Connector

WIRING DIAGRAM