

**APPLIANCE NAME:
KITCHENER 110 DF EU (FSD)**

DSL0279 P00
DATE 30.08.05 ISSUE STATUS 001



ALL MODELS

DSL0279 P01
DATE 30.08.05 ISSUE STATUS 001

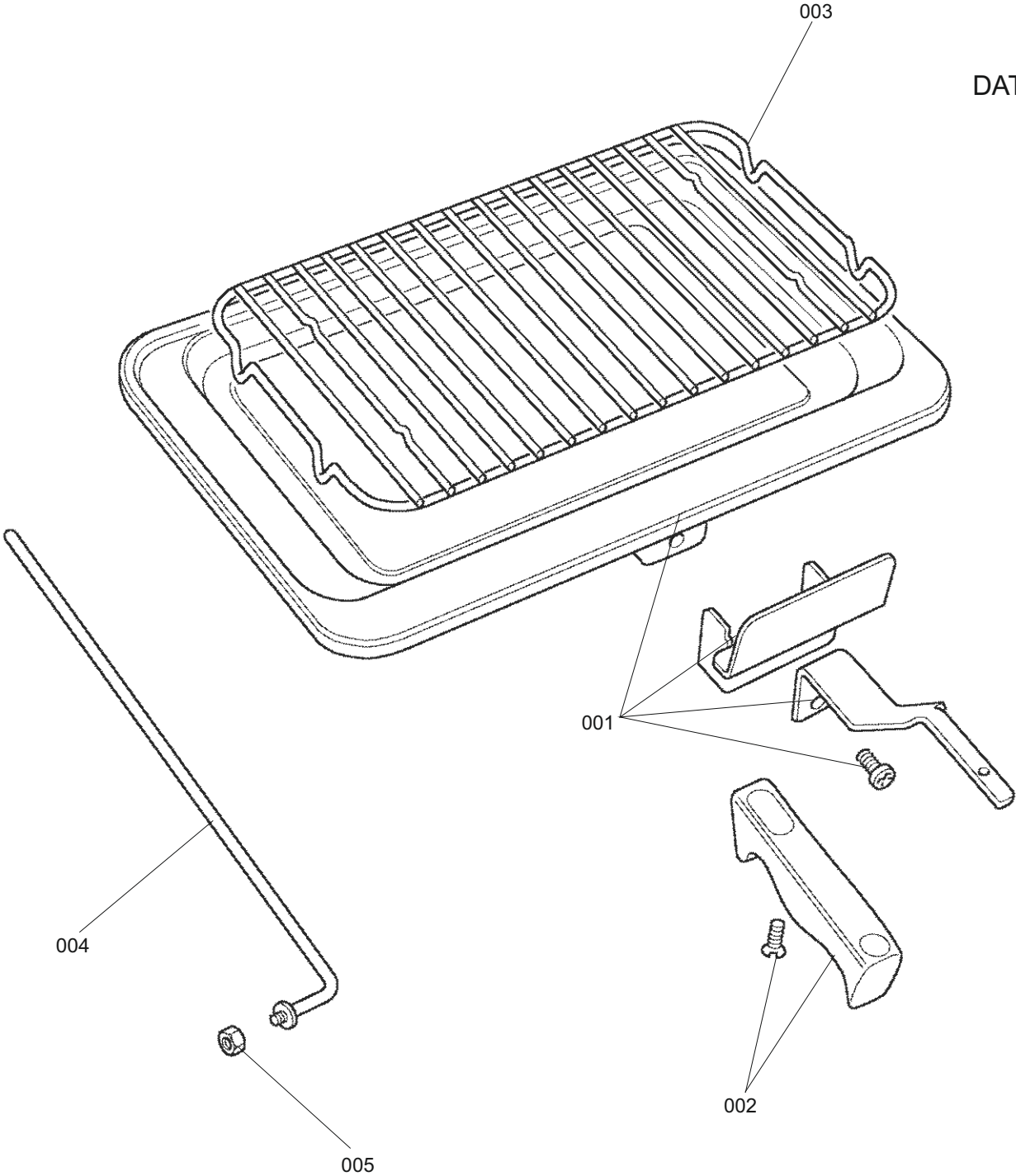

GRILL PAN

ALL MODELS

DSL0279 P02
DATE 30.08.05 ISSUE STATUS 001

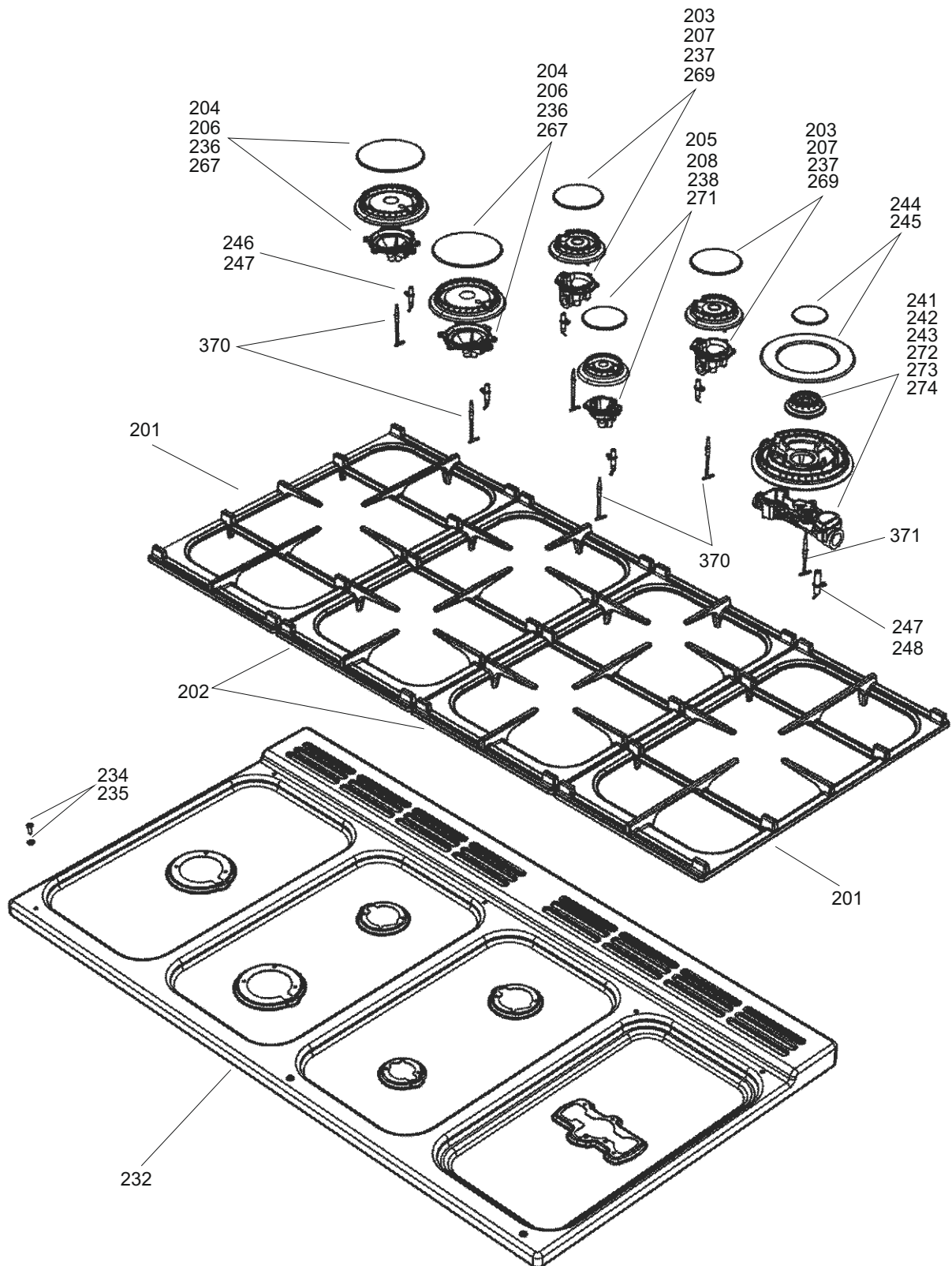

COOKER TOP

ALL MODELS

DSL0279 P03
DATE 26.06.09 ISSUE STATUS 02

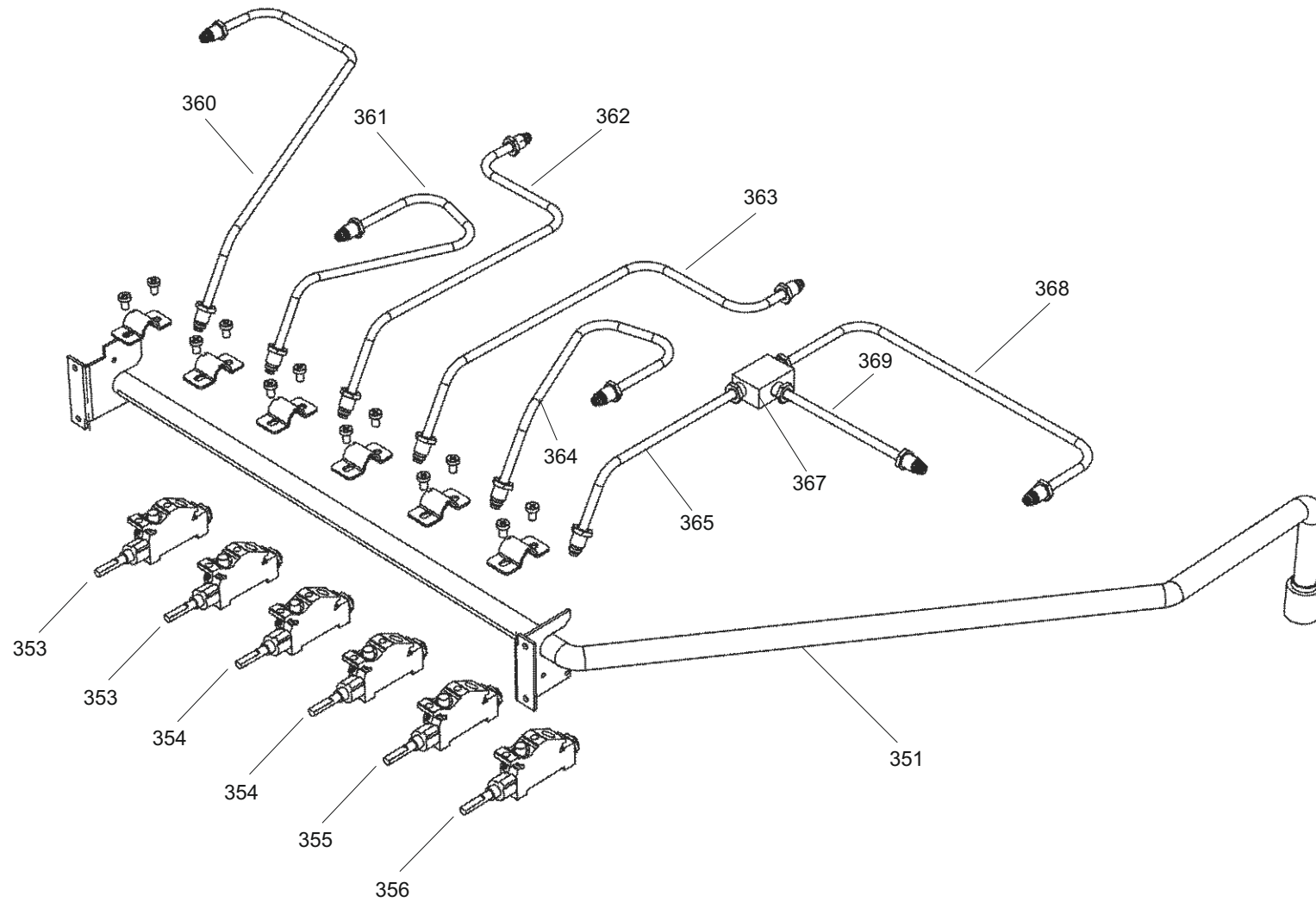

GAS RAIL - TAPS - INJECTORS AND PIPES

ALL MODELS
FROM SERIAL NUMBER 158000

DSL0279 P04A
DATE 04.07.11 ISSUE STATUS 02

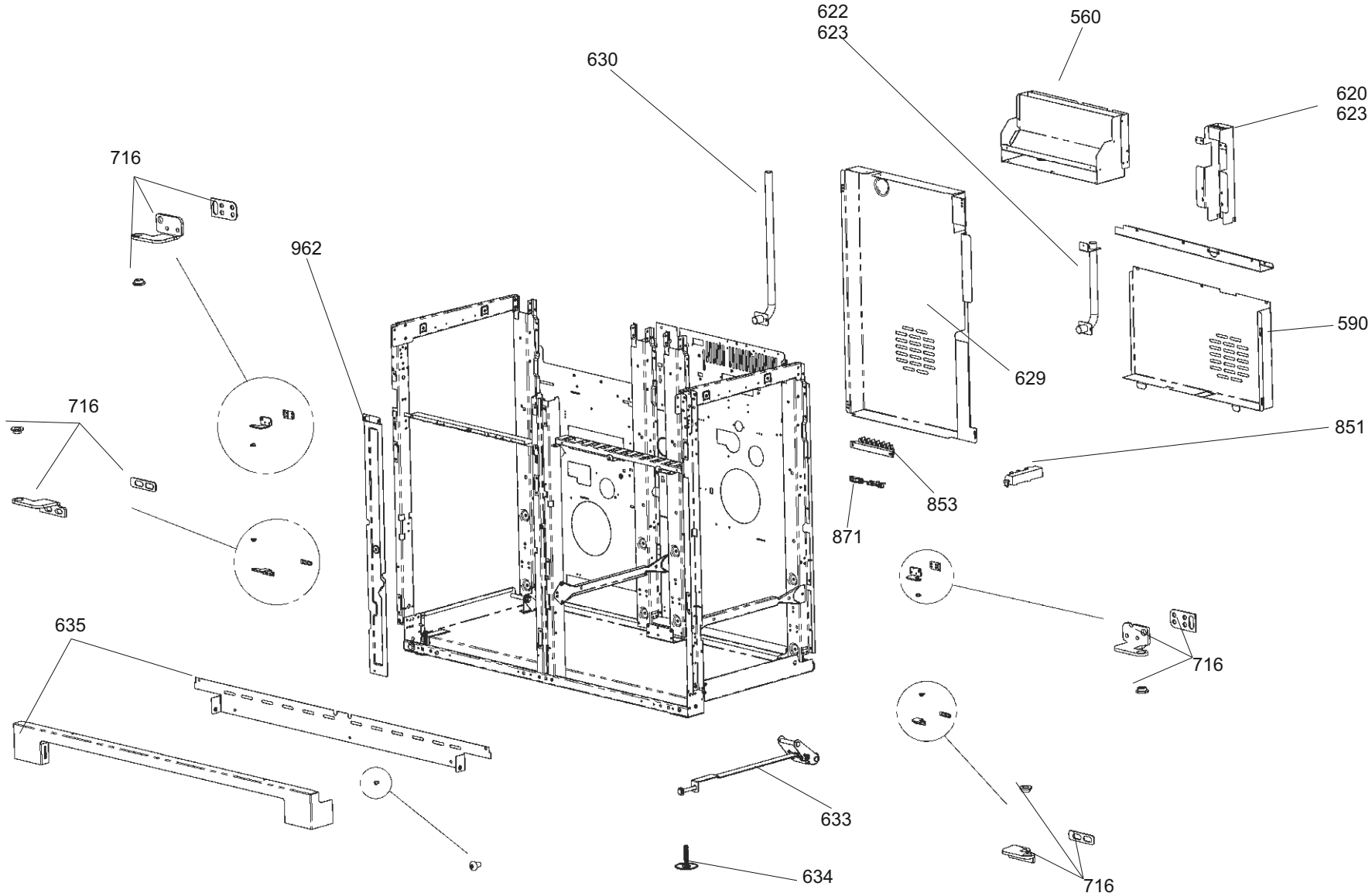

CHASSIS AND FRAME ASSEMBLY

ALL MODELS

DSL0279 P05
DATE 30.08.05 ISSUE STATUS 001

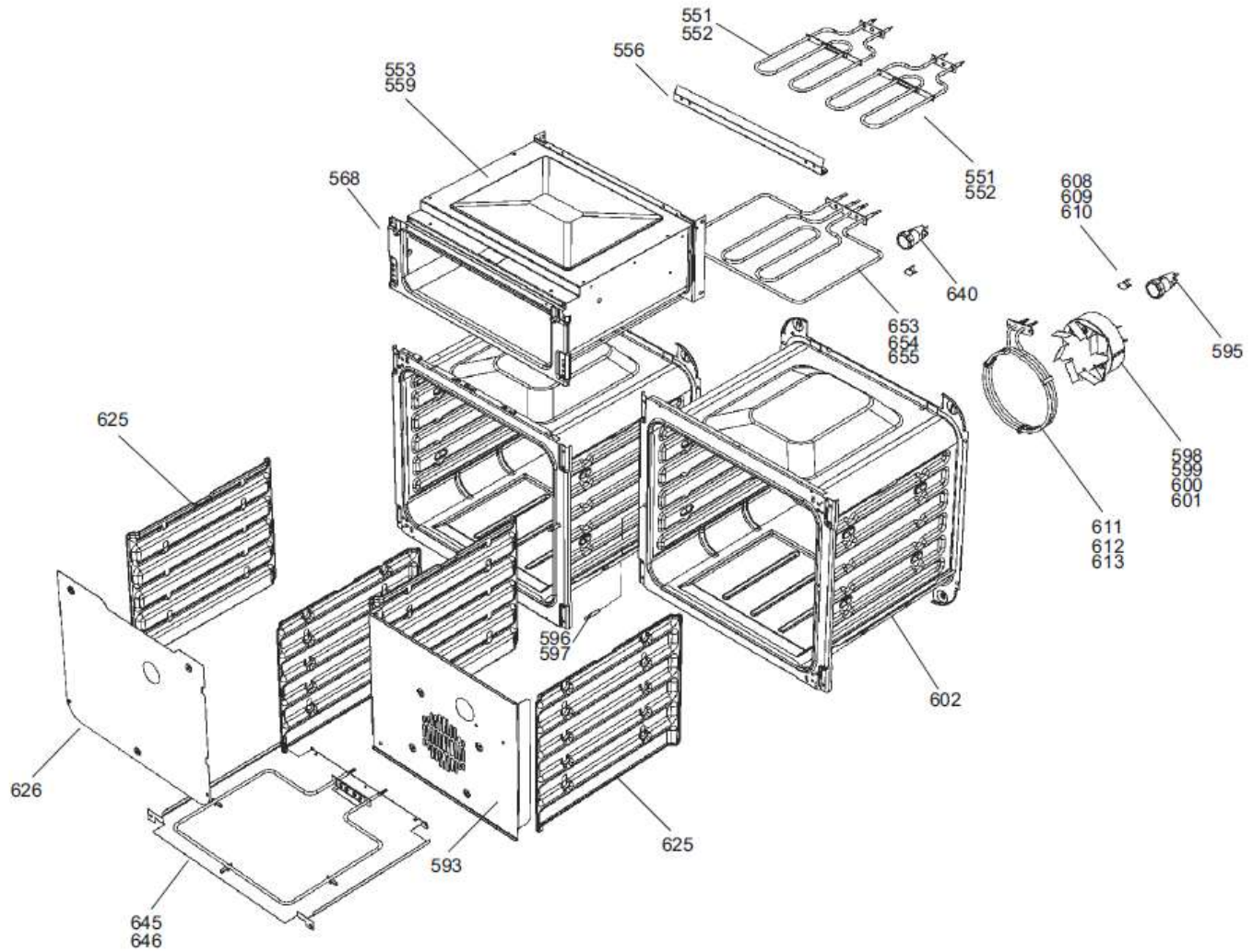

LH OVEN - RH OVEN AND GRILL CHAMBER

ALL MODELS

DSL0279 P06
DATE 30.08.05 ISSUE STATUS 001

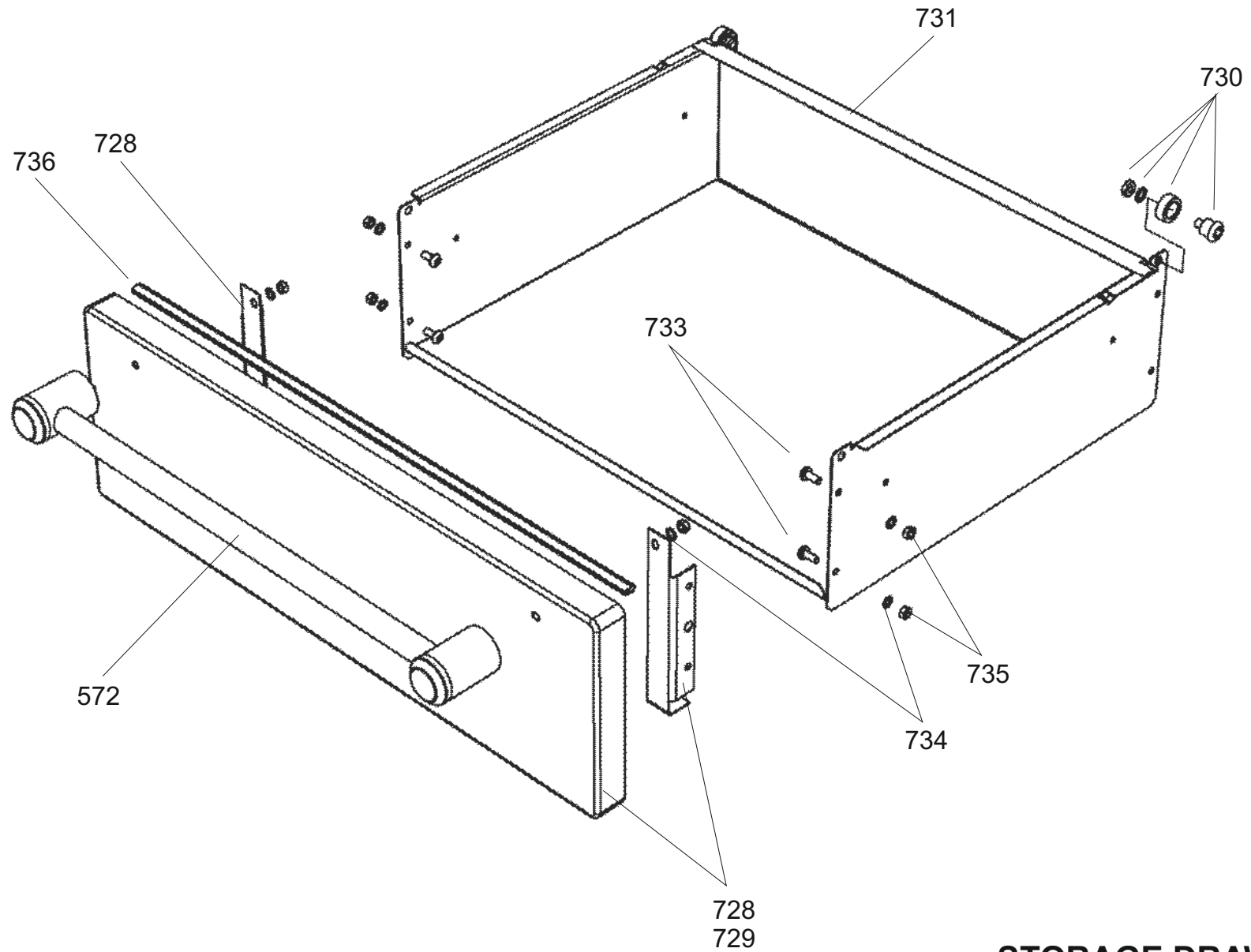

STORAGE DRAWER

ALL MODELS

DSL0279 P07
DATE 30.08.05 ISSUE STATUS 001

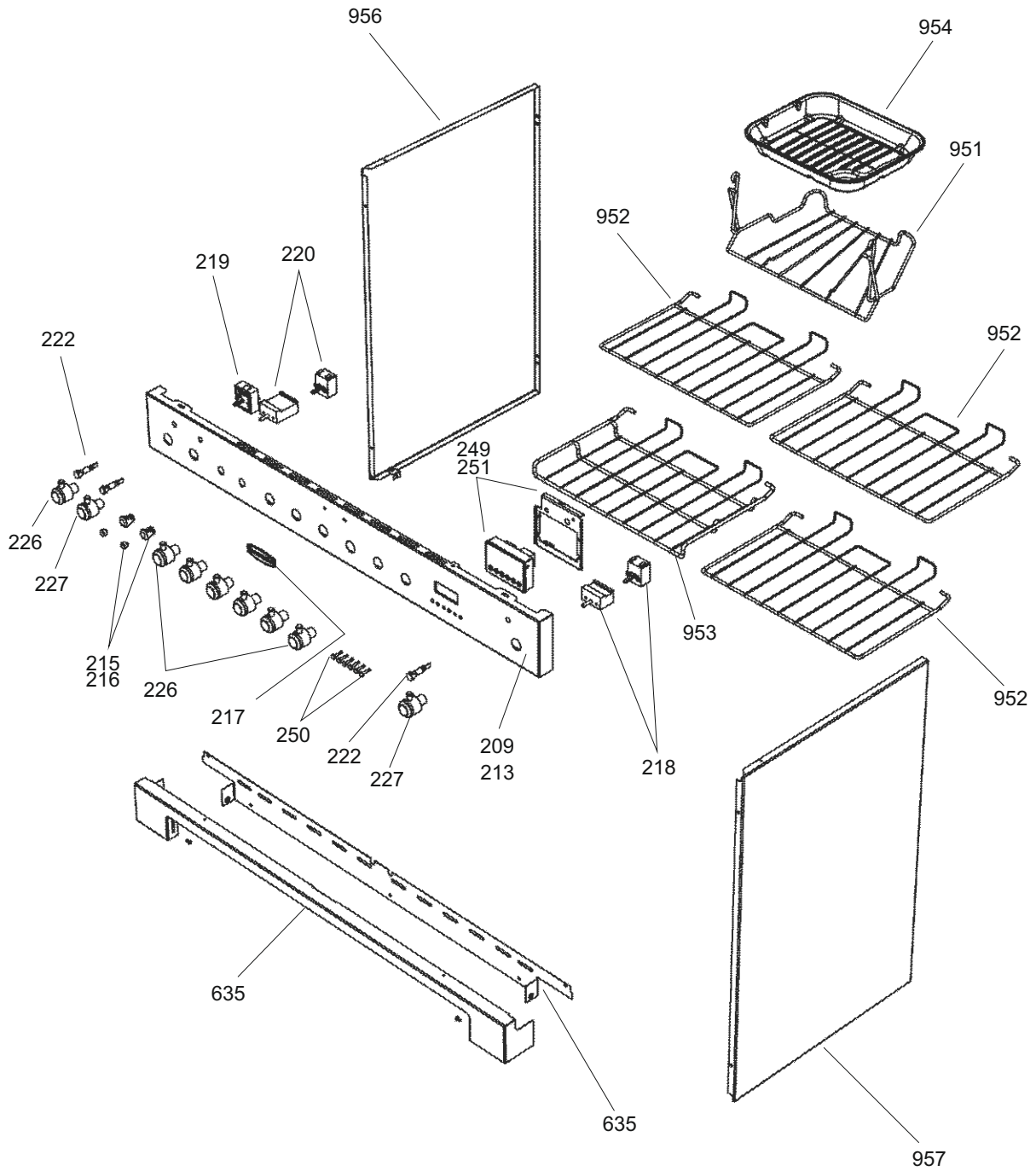

OVEN ACCESSORIES

ALL MODELS

DSL0279 P08
DATE 30.08.05 ISSUE STATUS 001

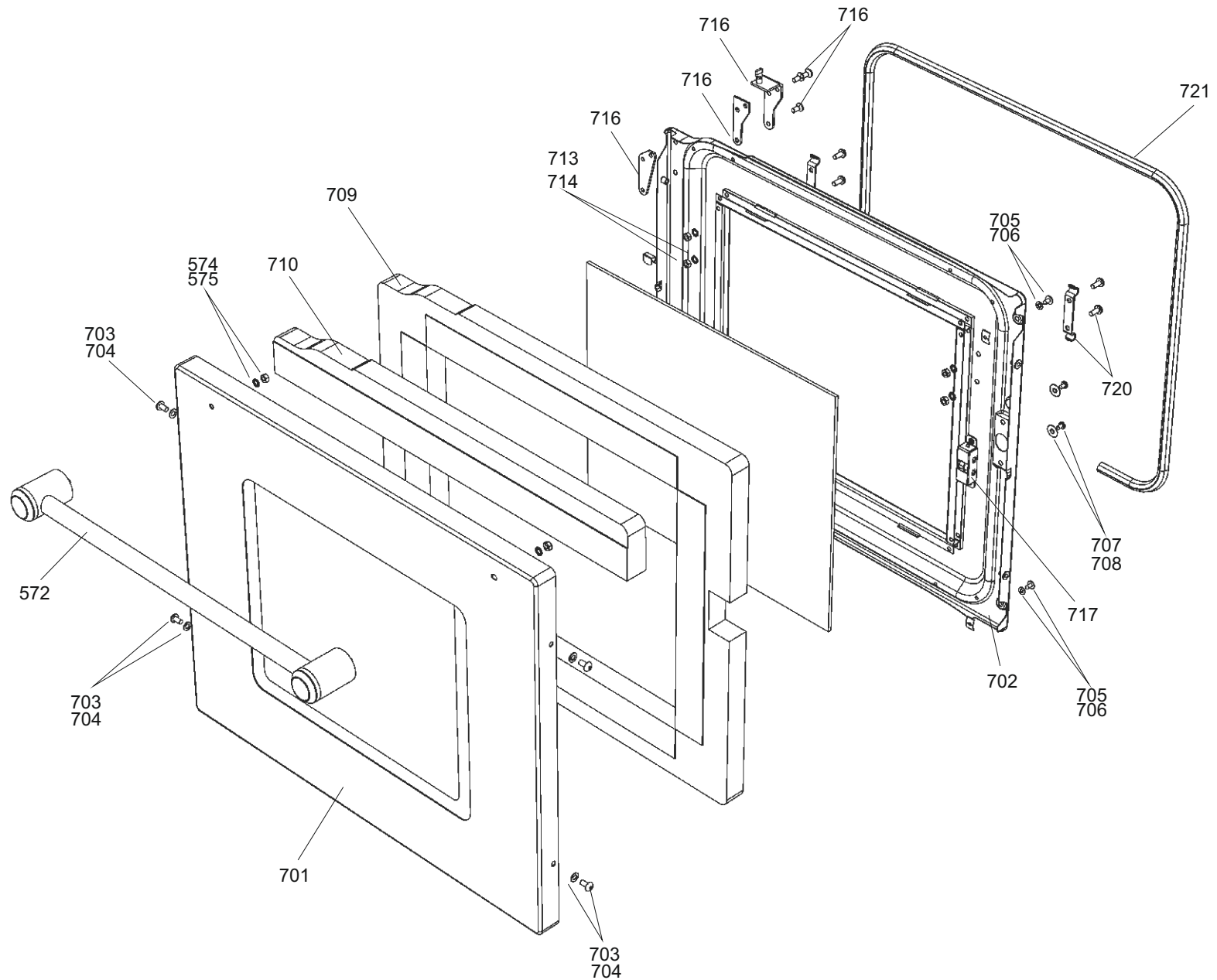

LH OVEN DOOR

ALL MODELS

DSL0279 P10
DATE 30.08.05 ISSUE STATUS 001

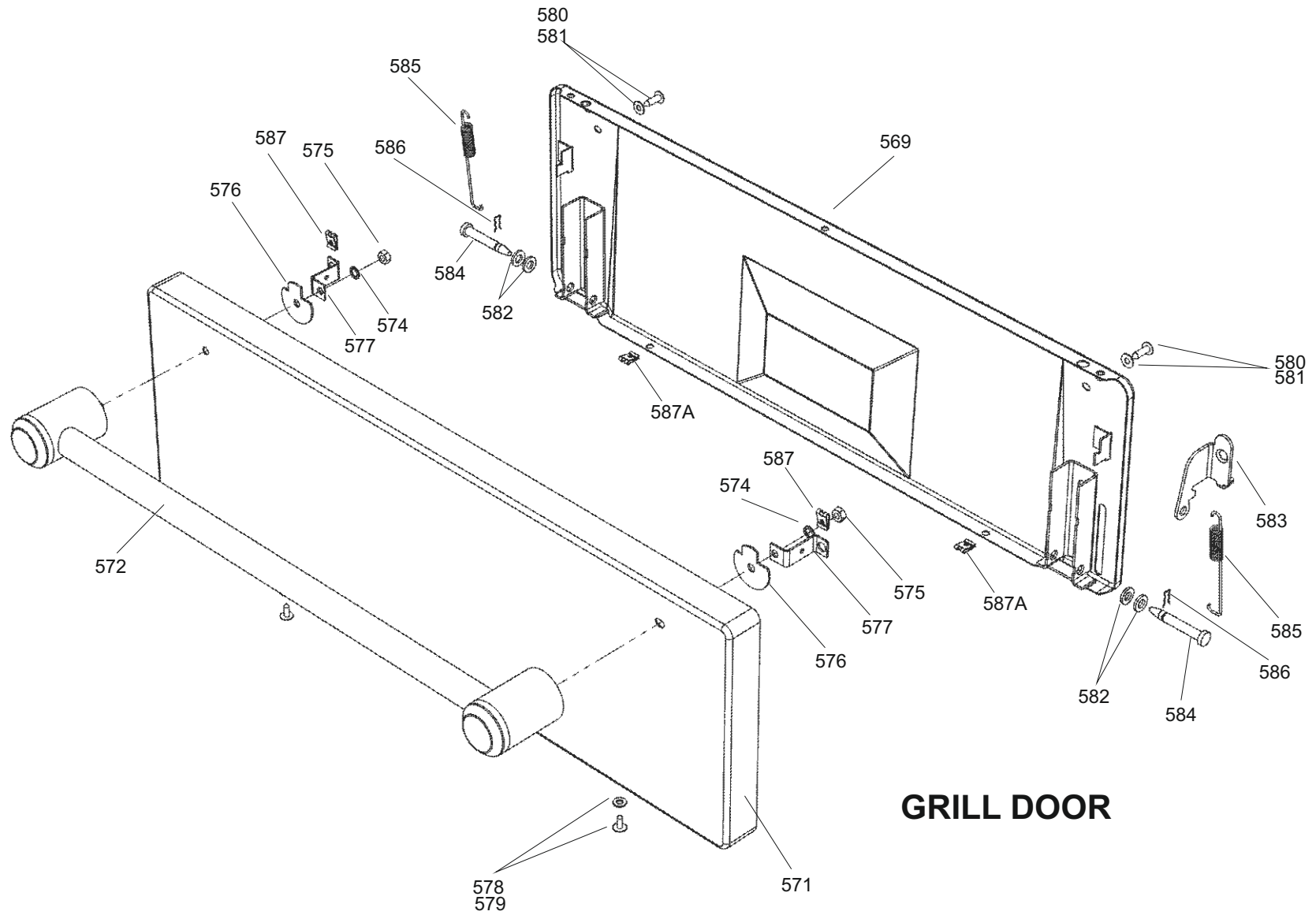

GRILL DOOR

UP TO SERIAL NUMBER 5999

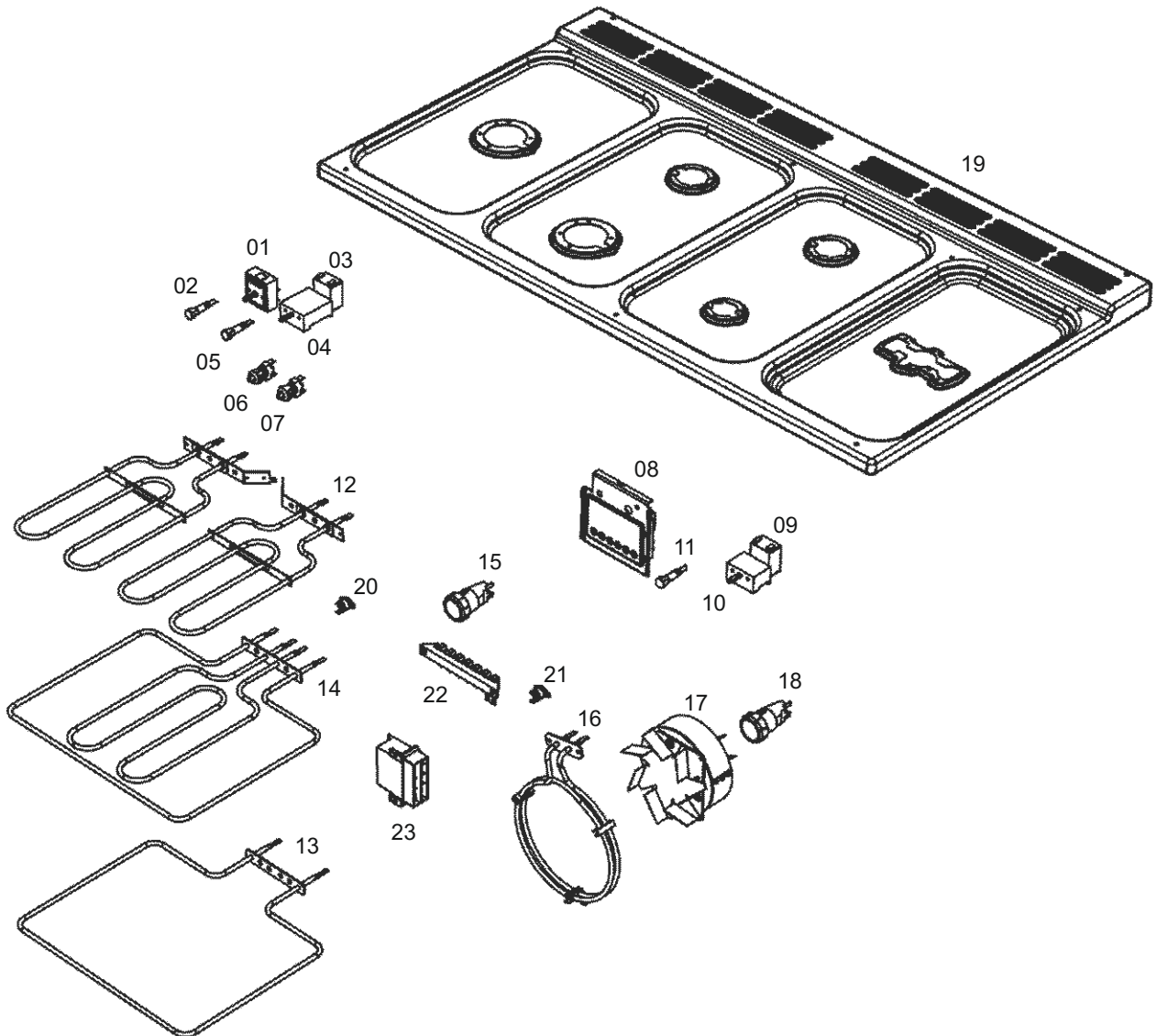

REF	HARNESS	DESCRIPTION	QTY	CONNECTS COMPONENTS
855	P094951	Grill Neon	01	01 02
856	P095565	LH Oven Thermostat Switch - Light	01	03 04 05
857	P026795	RH Oven Thermostat Switch - Clock	01	08 10
858	P094943	Hotplate/Thermostat Earth	02	19
859	P055374	Grill Element Earth	02	12
860	P095566	Top Element Neutral Link	01	14
861	P025994	Top Element Cut-Off Earth	01	15 21 22
862	P095450	RH Oven Earth	01	16 17 18 22
863	P094948	RH Cut-Off Link	01	16 21
864	P025995	RH Oven Neutral Link	01	16 17 18
865	P094927	LH Bottom Element Harness	01	13 14 18 20 22
870	P037863	Thermostat - Fan Switch	01	09 10
867	P037442	LH Harness	01	01 02 03 04 05 06 07 12 14 20 22
868	P037443	RH Harness	01	08 09 10 11 15 17 18 22 23
869	P037664	LH Thermostat Earth	01	03
866	A026794	HT Harness	01	23

FALCON KITCHENER 110 DF/NG FSD

FROM SERIAL NUMBER 6000

DSL0279 P11A

ISSUE STATUS 01 DATE 22.01.10

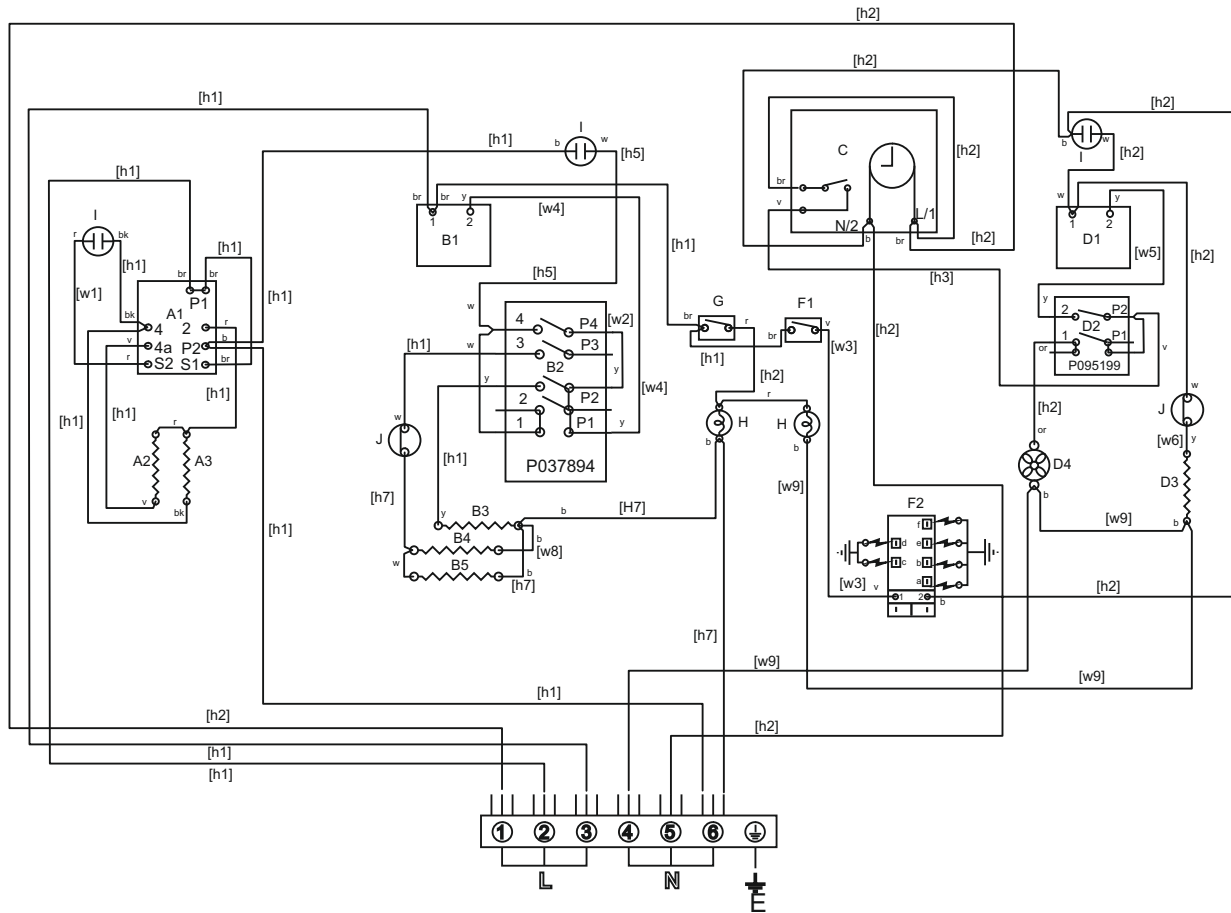

Code	Description
b	Blue
br	Brown
bk	Black
or	Orange
r	Red
v	Violet
w	White
y	Yellow
g/y	Green / Yellow

Code	Description
A1	Grill Energy Regulator
A2	Left Hand Grill Element
A3	Right Hand Grill Element
B1	Left Hand Oven Thermostat
B2	Left Hand Oven Switch
B3	Left Hand Oven Browning Element
B4	Left Hand Oven Top Element
B5	Left Hand Oven Bottom Element
C	Clock
D1	Right Hand Oven Thermostat
D2	Right Hand Oven Front Switch
D3	Right Hand Oven Element
D4	Right Hand Oven Fan
F1	Spark Ignition Switch
F2	Spark Generator
G	Light Switch
H	Light Left Hand / Right Hand
J	Thermal Cut-Out

WIRING DIAGRAM