

**PAN SUPPORTS  
BURNERS & HOTPLATE ASSEMBLY**

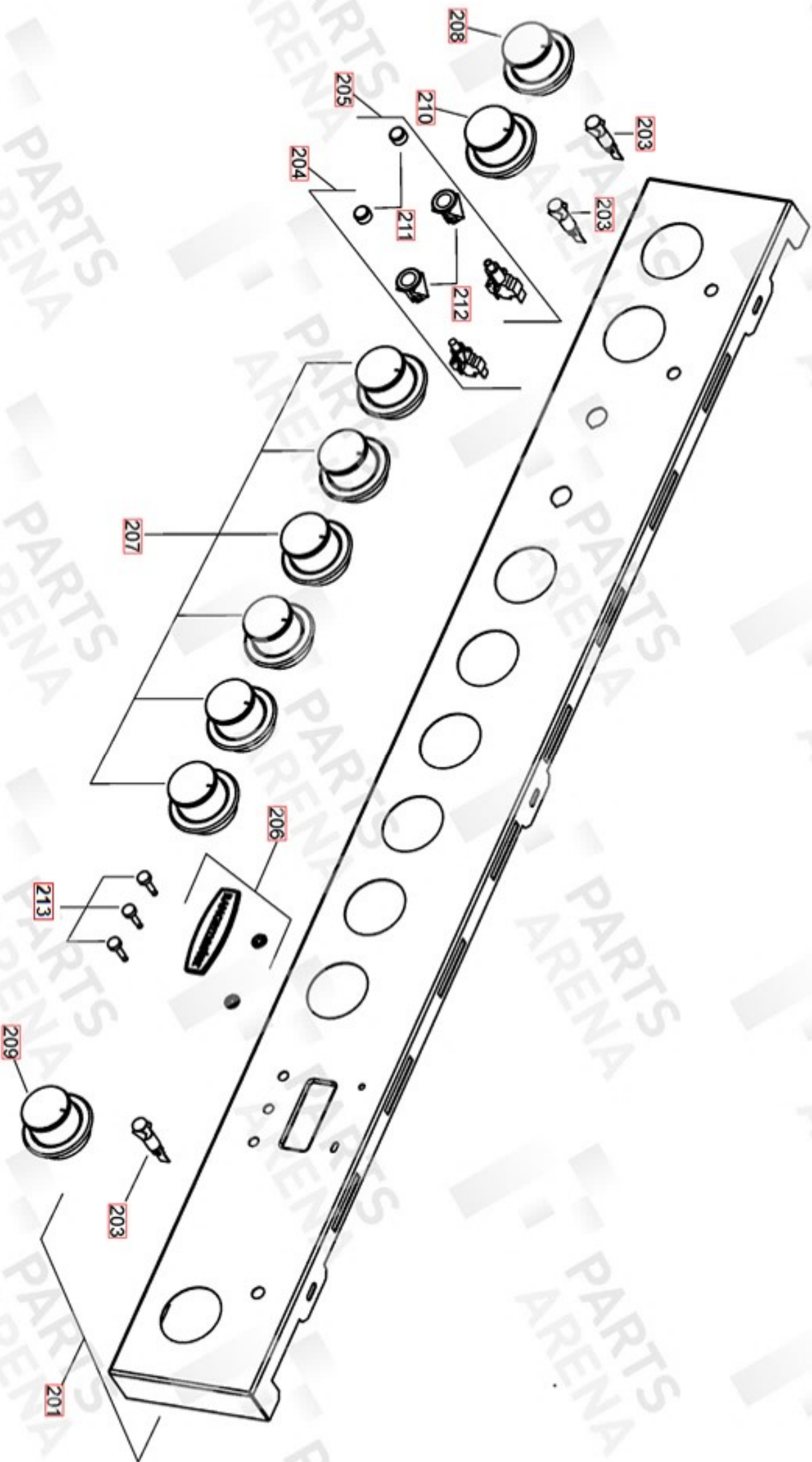

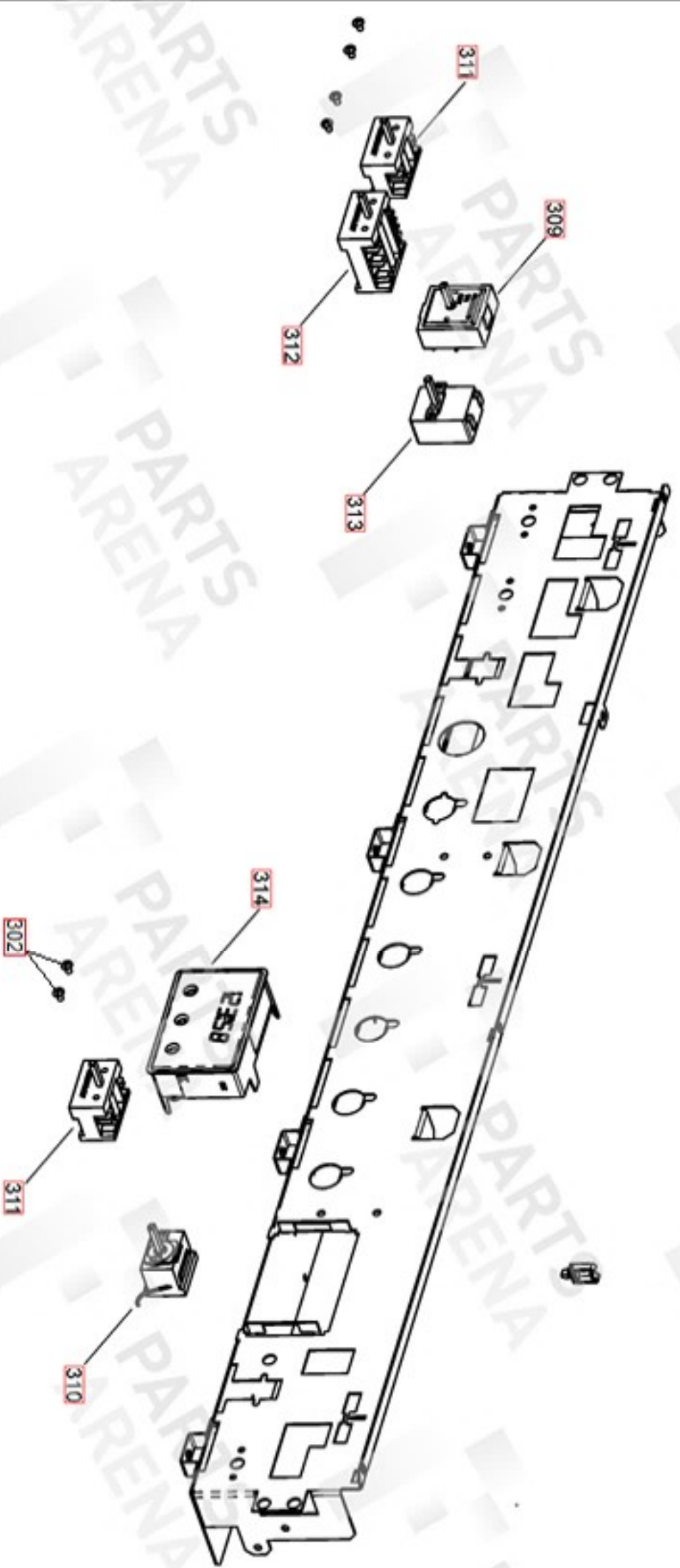

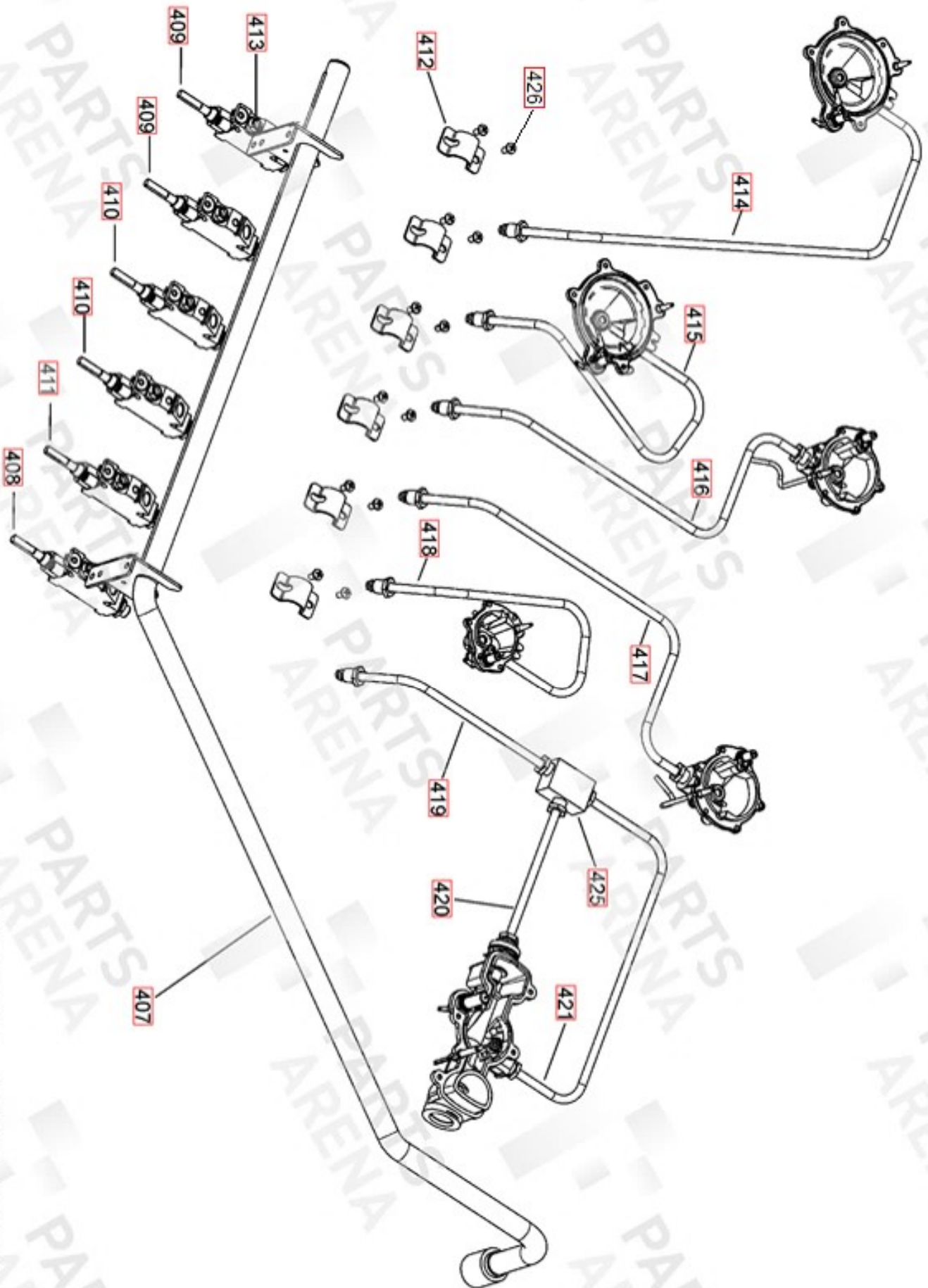

GAS RAIL, TAPS AND BURNERS

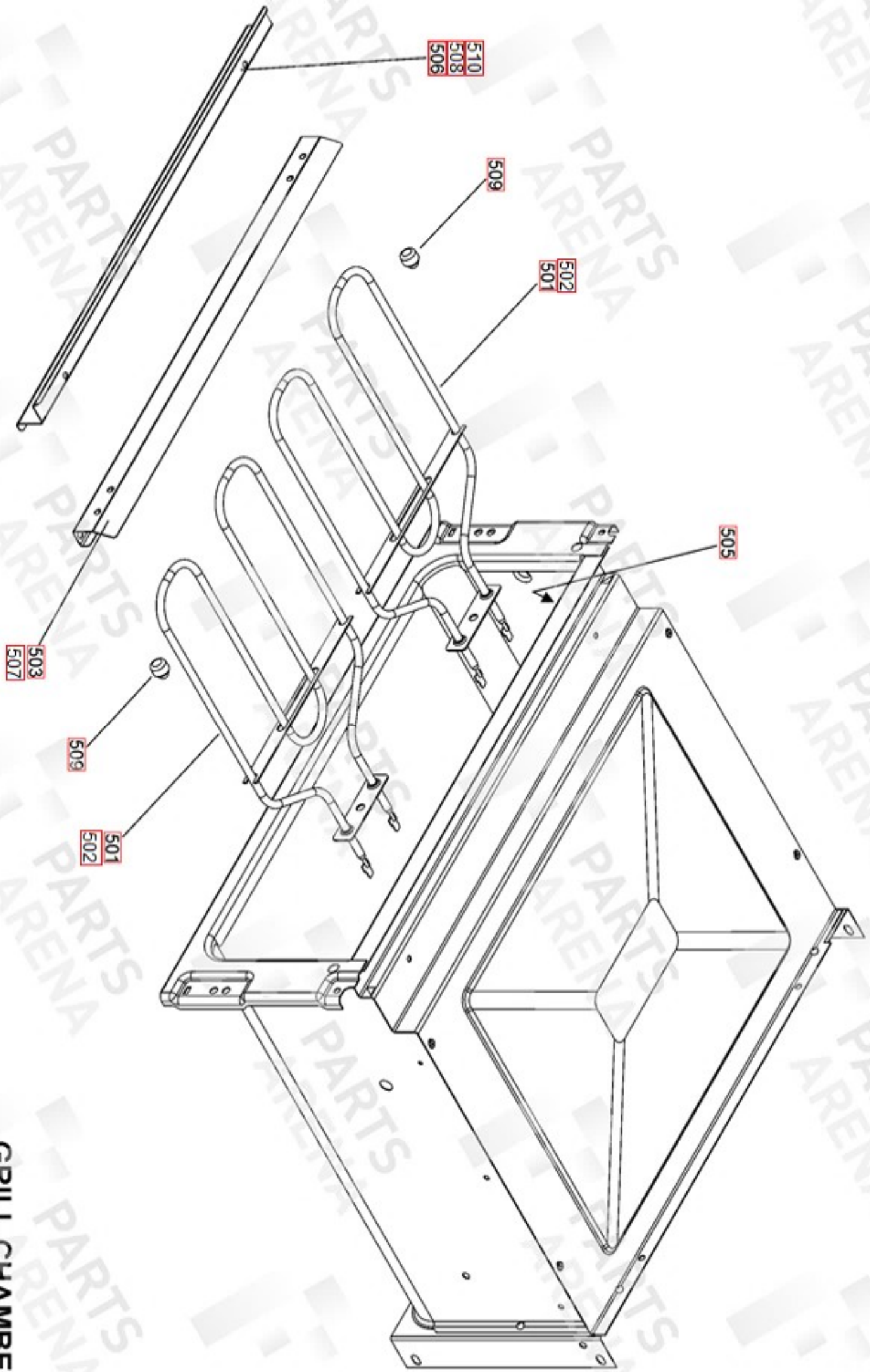

GRILL CHAMBER

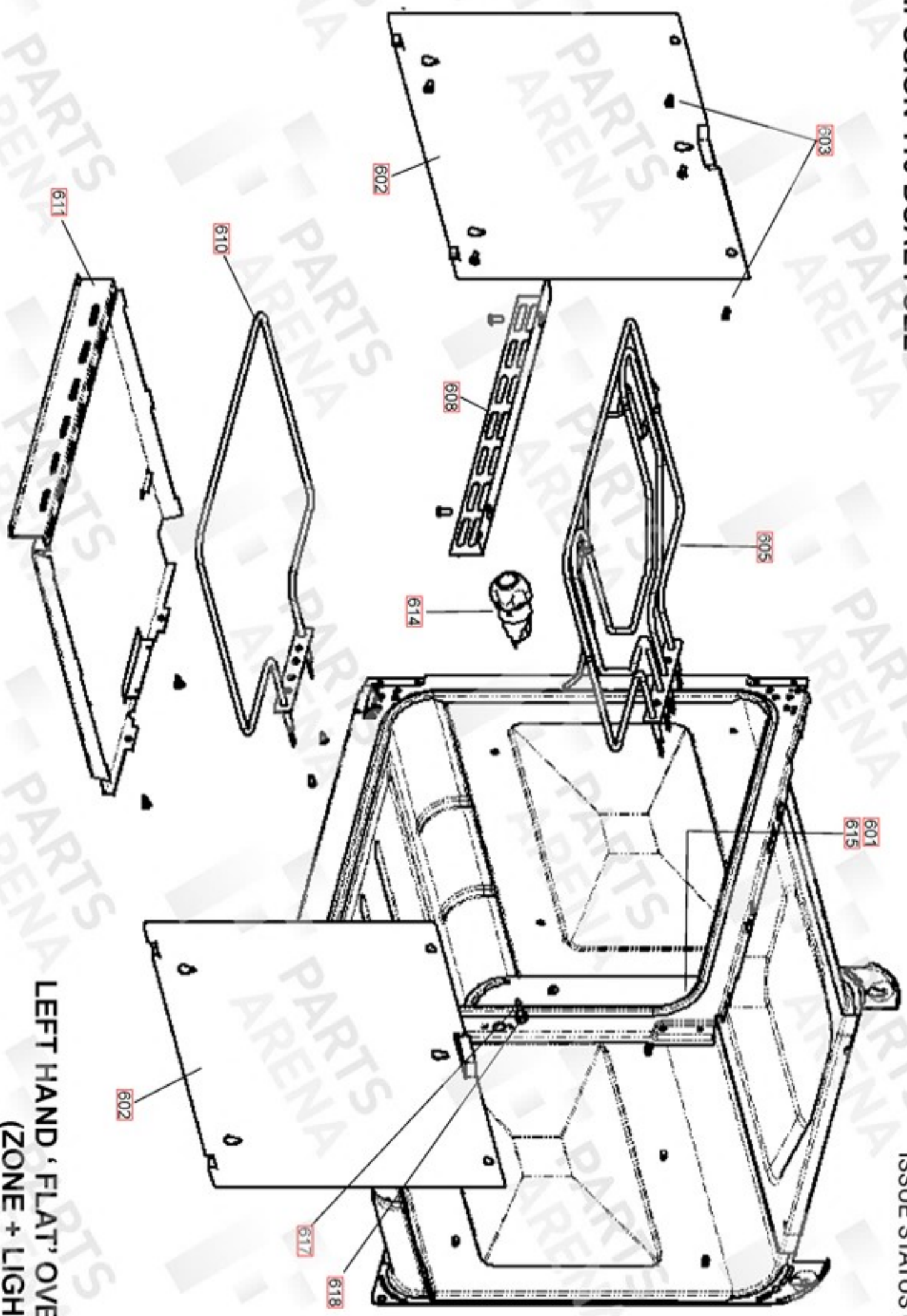

LEFT HAND 'FLAT' OVEN  
(ZONE + LIGHT)

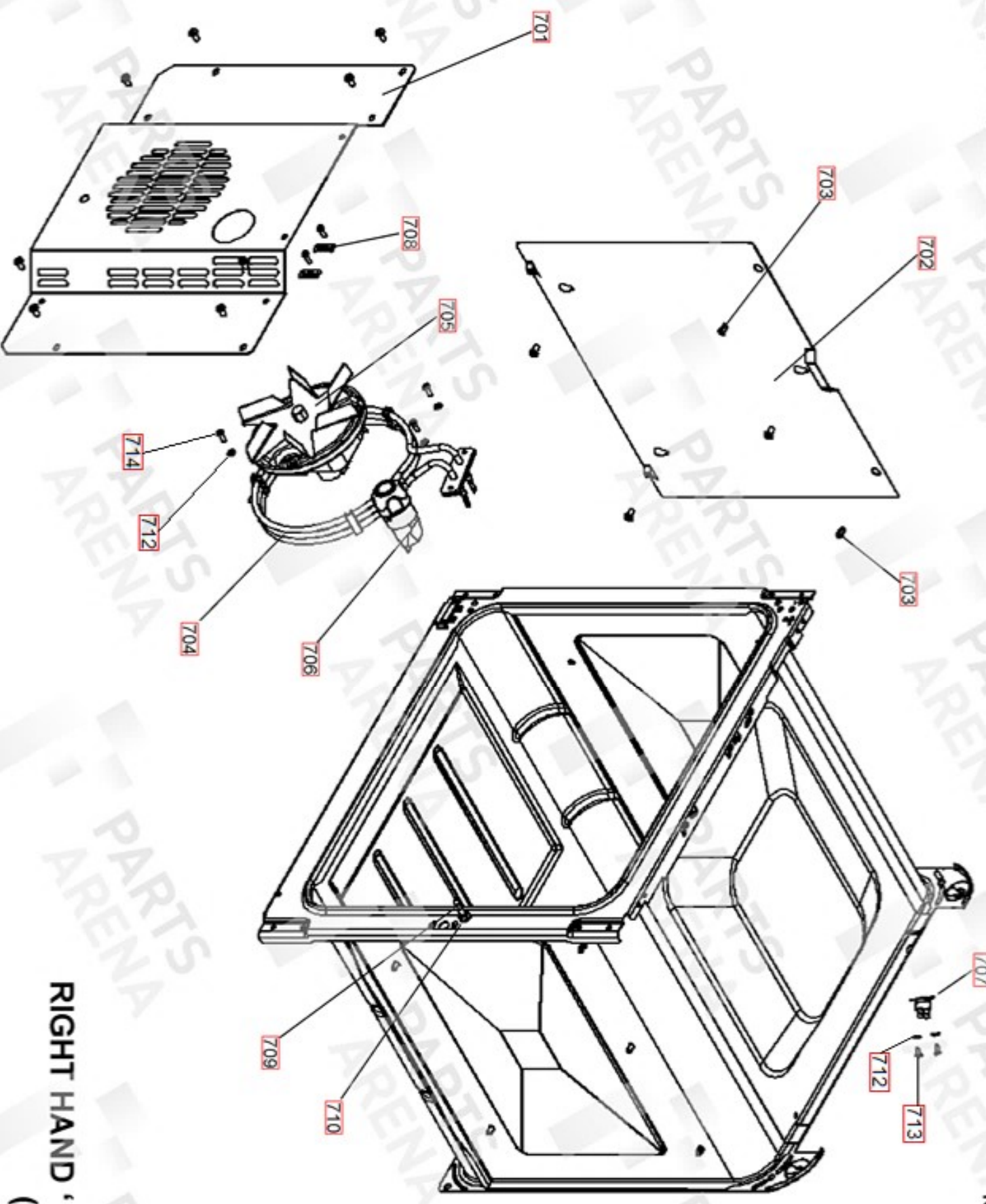

RIGHT HAND 'FLAT' OVEN  
(FAN+LIGHT)



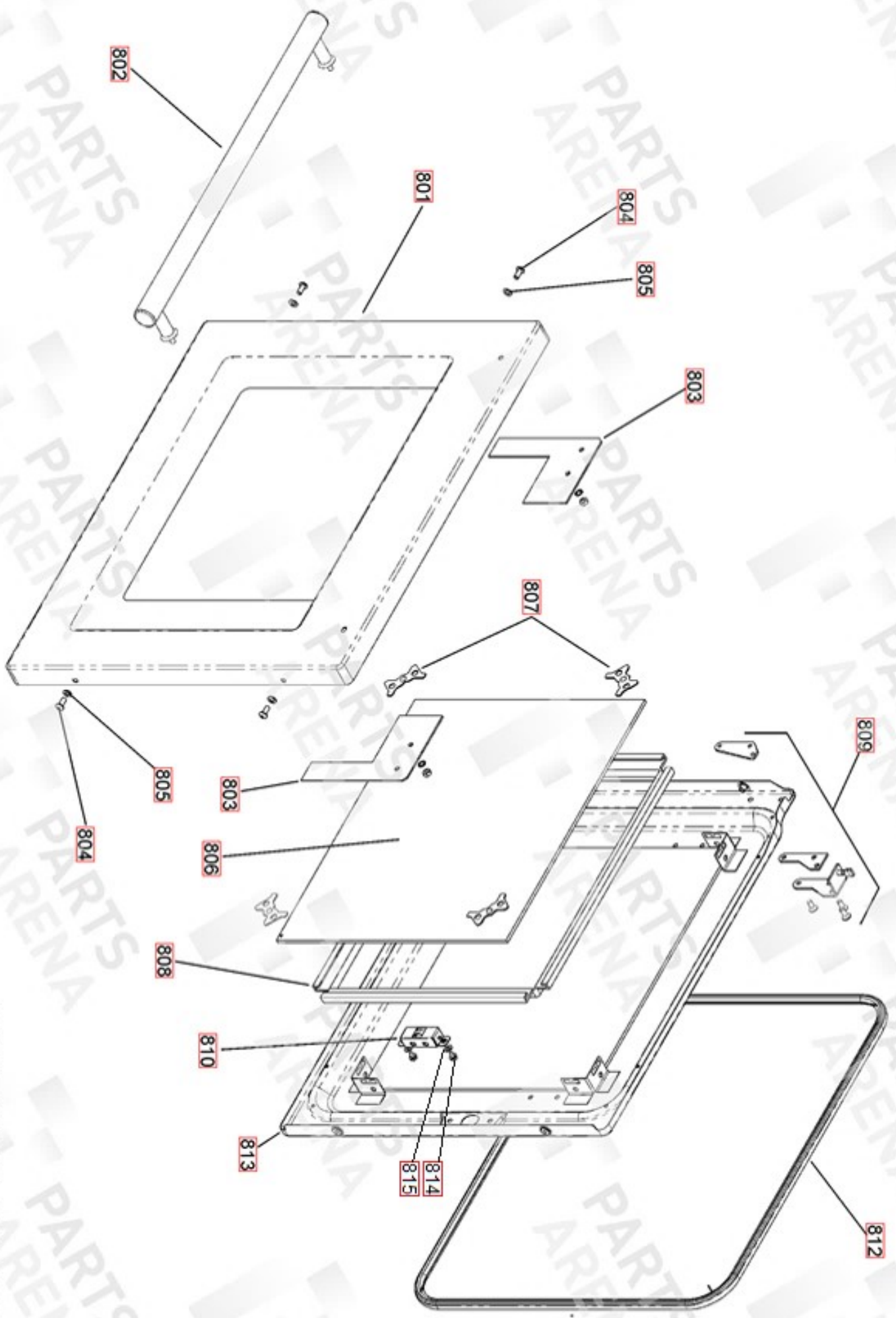

LEFT HAND OVEN DOOR

RIGHT HAND OVEN DOOR

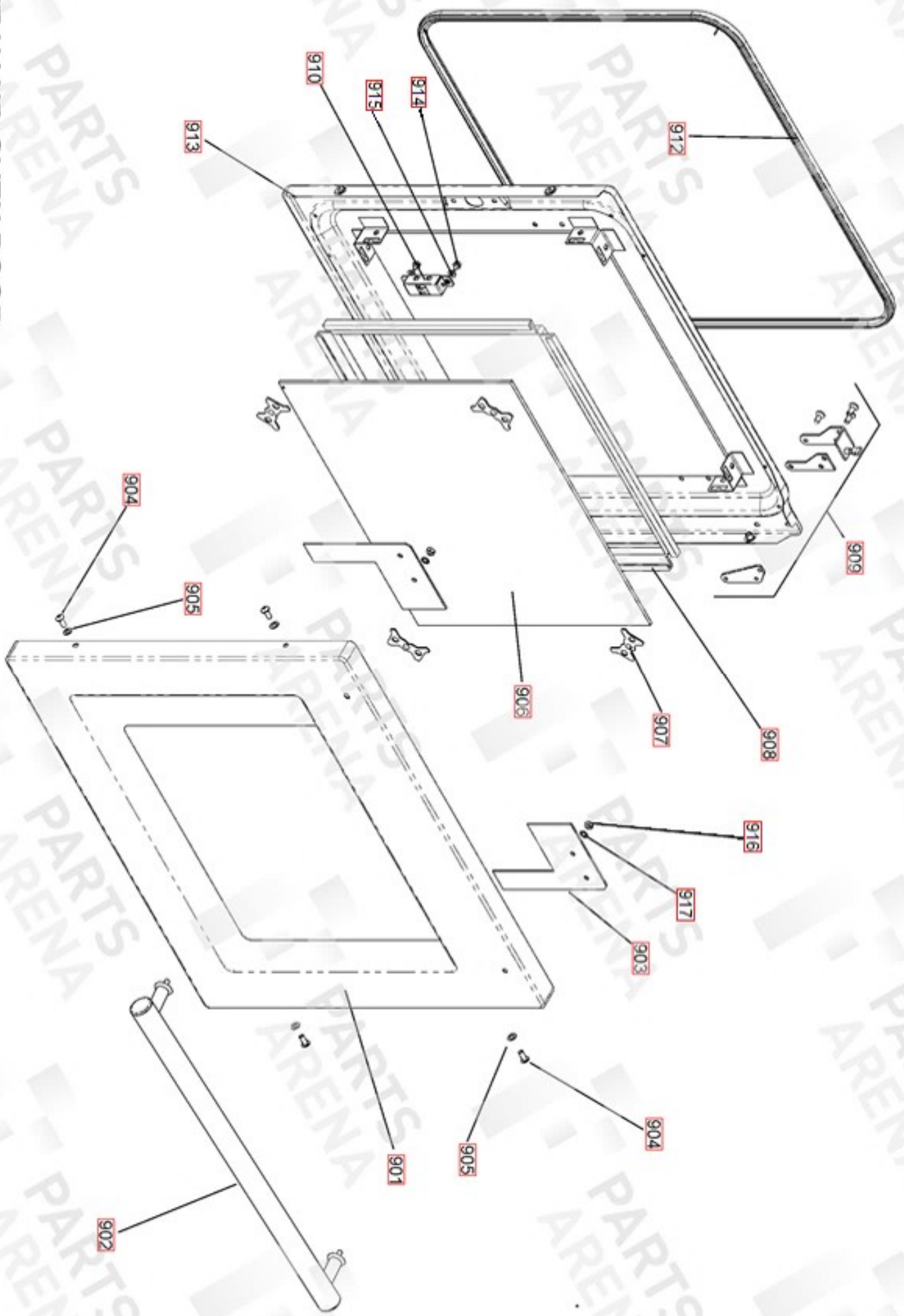

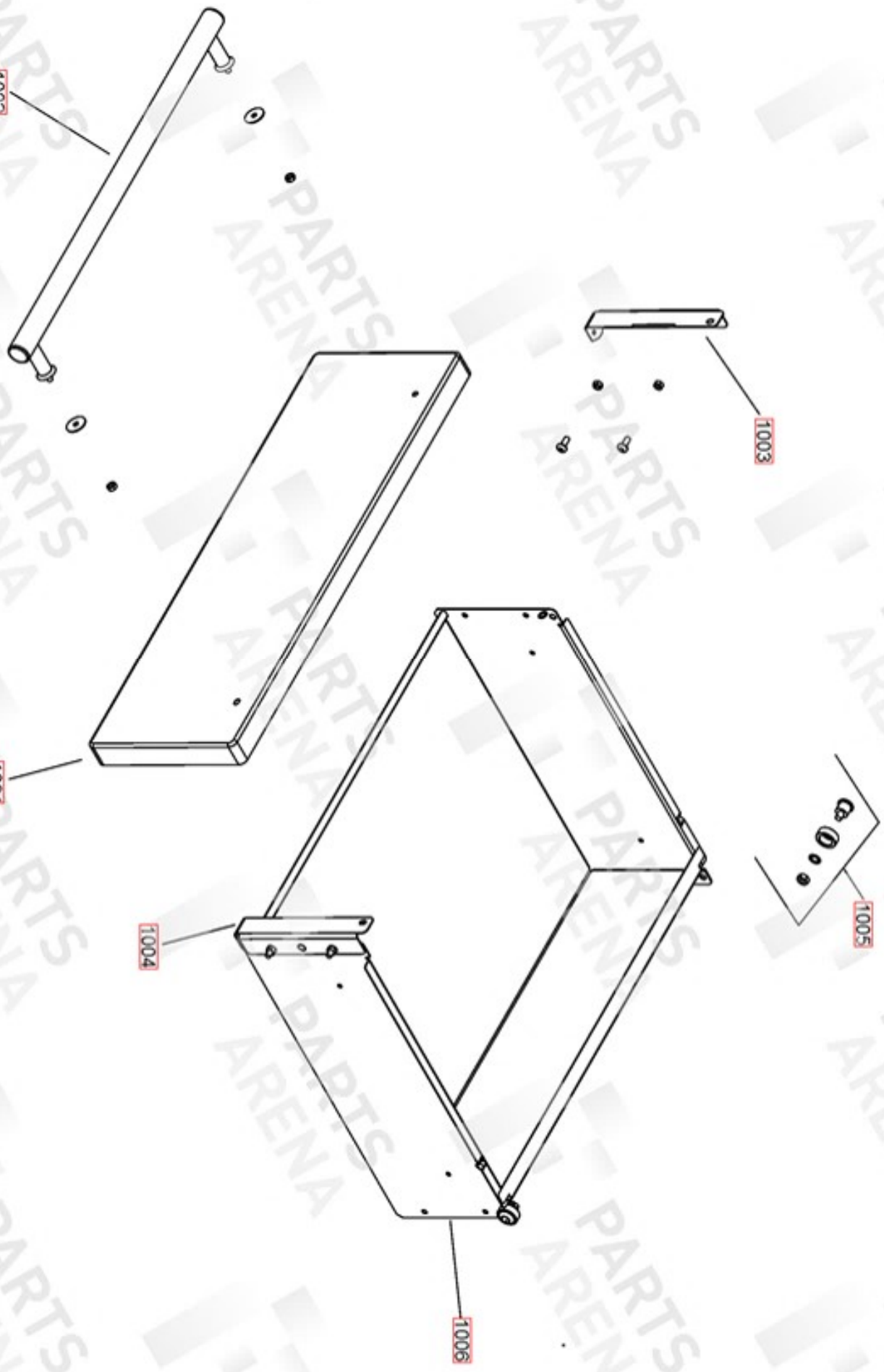

STORAGE DRAWER

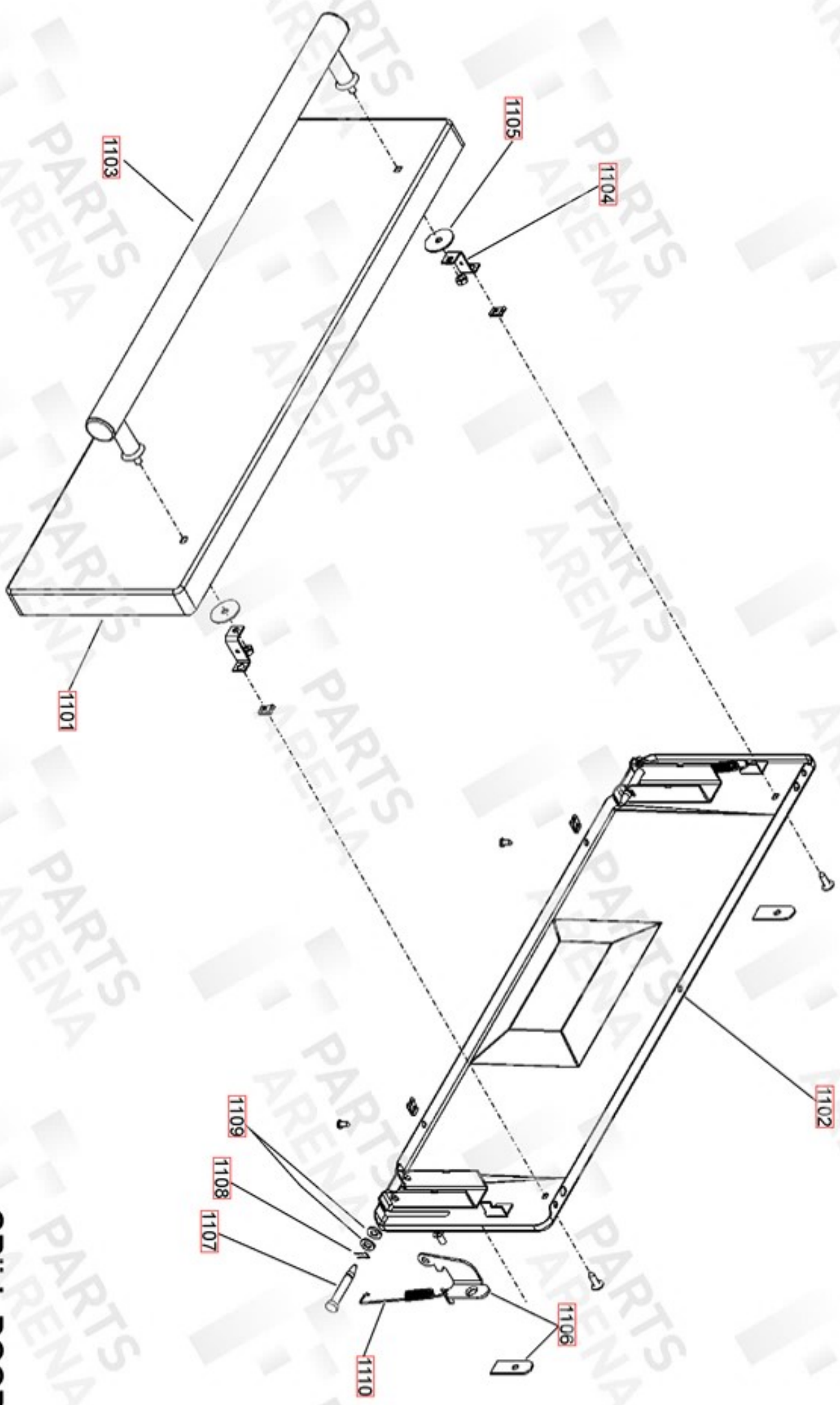

GRILL DOOR

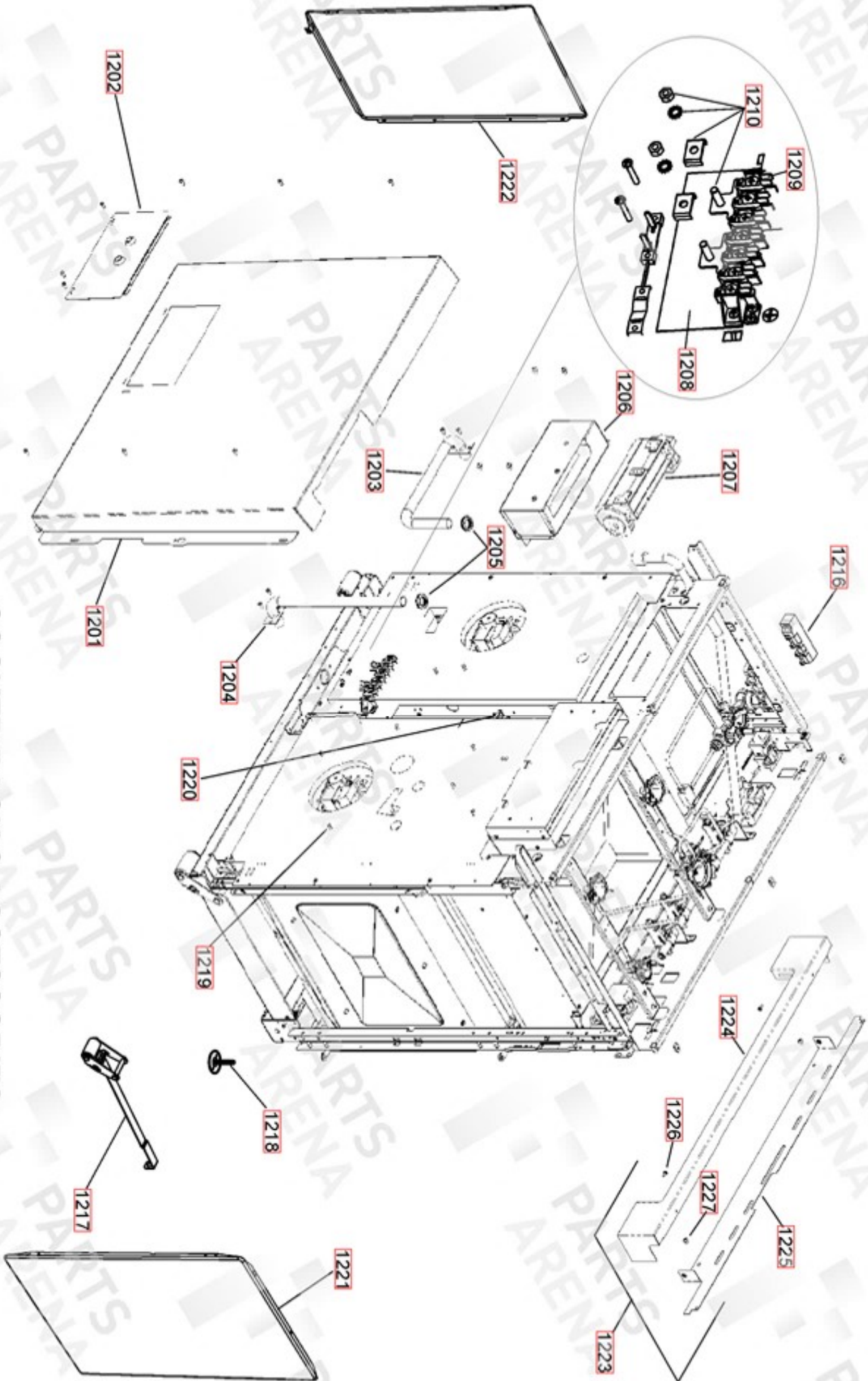

COOKER BACK & ACCESSORIES

FALCON / RANGEMASTER  
INFUSION 110 DUAL FUEL

DATE 06.12.17

DSL0716 P13  
ISSUE STATUS 01

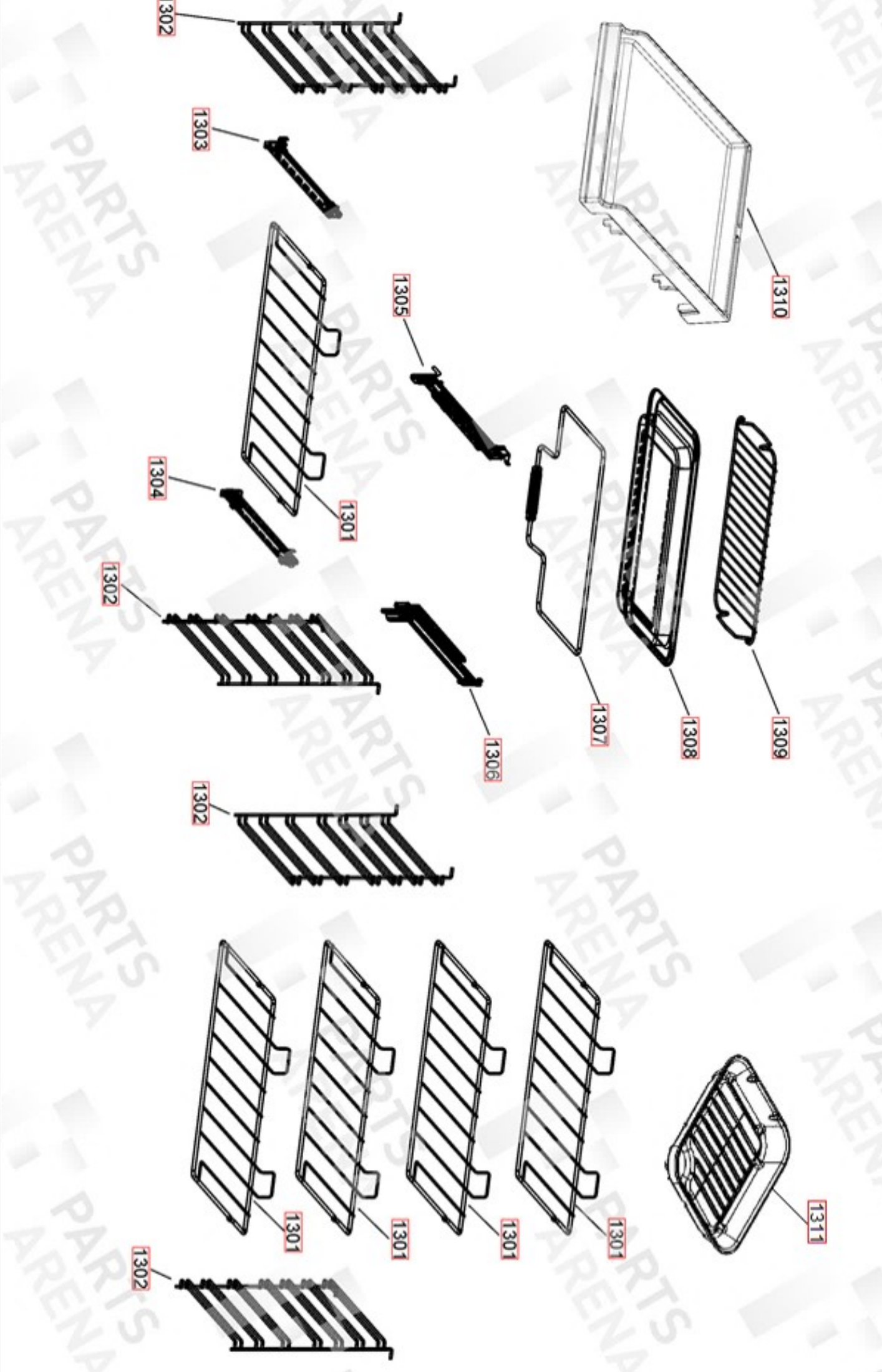

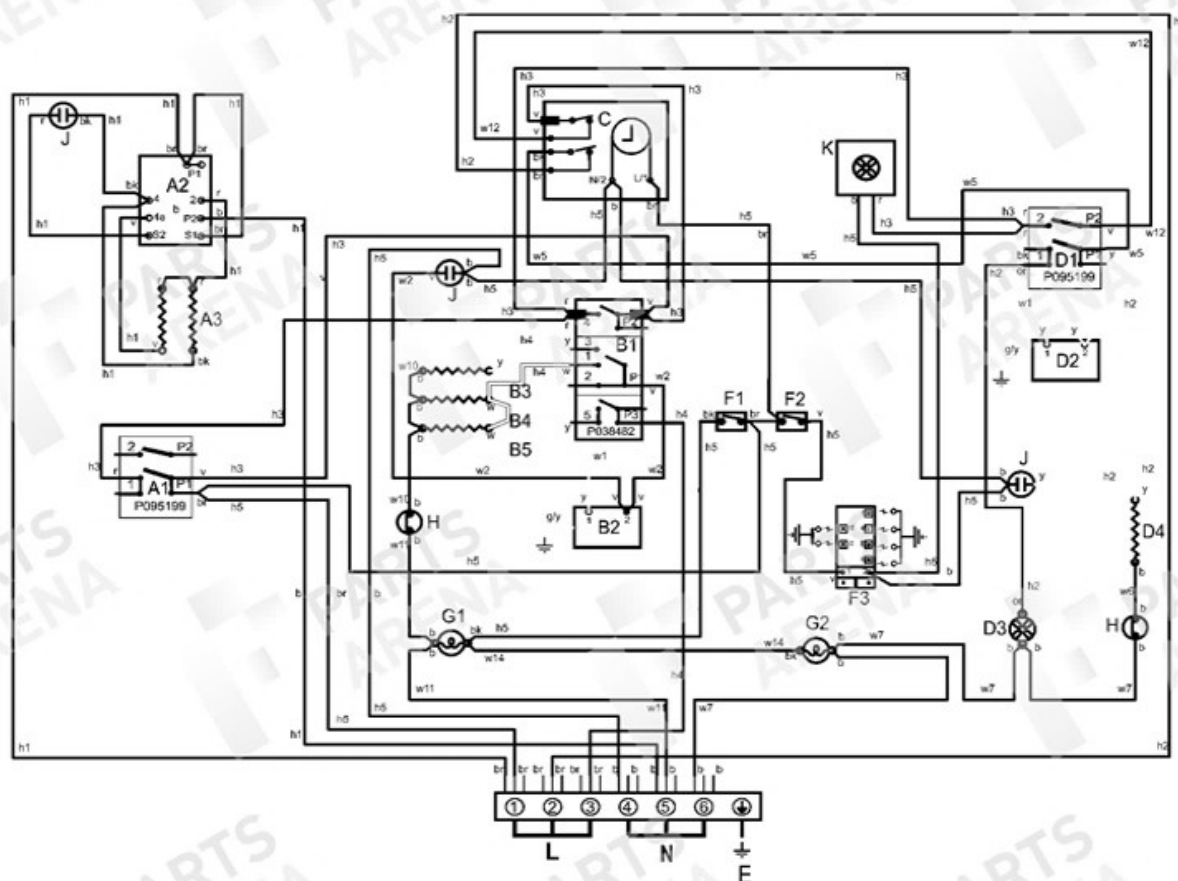

Key

The connections shown in the circuit diagram are for single-phase. The ratings are for 230V 50Hz

Code	Description
A1	Grill front switch
A2	Grill energy regulator
A3	Grill elements
B1	Zoned oven front switch
B2	Zoned oven thermostat
B3	Zoned oven browning element (inner pair)
B4	Zoned oven top element (outer pair)
B5	Zoned oven base element
C	Clock
D1	Right-hand oven front switch
D2	Right-hand oven thermostat

Code	Description
D3	Right-hand oven fan
D4	Right-hand oven element
F1	Oven light switch
F2	Ignition switch
F3	Ignition spark generator
G1	Left-hand oven light
G2	Right-hand oven light
H	Thermal cut-out
J	Neon
K	Cooling fan

Code	Colour
b	Blue
br	Brown
bk	Black
or	Orange
r	Red
v	Violet
w	White
y	Yellow
g/y	Green/yellow

Ref N°	Part N°	Quantity	Colour	Description
w1	P037863	2	y	WIRE ASSEMBLY - YELLOW LINK
w2	P064457	1	v	WIRE ASSY VIOLET - OVEN NEON LINK
h1	P064445	1	r/bl/b/v/br	HARNESS - GRILL
w3	P055374	2	g/y	NI - WIRE ASSEMBLY - GRILL EARTHS LINKS
h2	P064454	1	or/br/y	FANNED OVEN HARNESS
w4	P094943	2	g/y	NI - WIRE ASSEMBLY - OVEN STAT EARTH LINK
h3	P066163	1	r/v	HARNESS - COOLING/ZONED
h4	P064451	1	w/y/br	HARNESS - LH ZONED OVEN
w5	P049233	1	bl	FEED WIRE - RH OVEN SWITCH - TIMER
w6	P040066	1	b	WIRE ASSY - NEUTRAL LINK
w7	P025995	1	b	WIRE ASSEMBLY - NEUTRAL LINK
w8	P095450	1	g/y	NI - WIRE ASSEMBLY - EARTH LINK
w9	P027672	1	g/y	NI - WIRE ASSY - EARTH LINK
w10	P040694	1	b	WIRE ASSY (NEUTRAL BLUE DAISY)
w11	P043965	1	b	WIRE 2 LINK RETURN LH OVEN
w12	P045407	1	v	WIRE TIMER RELAY TO RH OVEN
w13	P049292	1	clear	HT WIRE
h4	P049242	1	clear	HT HARNESS
h5	P066225	1	bl/br/b/v	HARNESS AUX
w14	P066240	1	bl	WIRE ASSY - BLACK LIGHT LINK