

FALCON 900S INDUCTION

UP TO SERIAL NUMBER 161999

DATE 25.07.13

DSL0418 P02
ISSUE STATUS 03

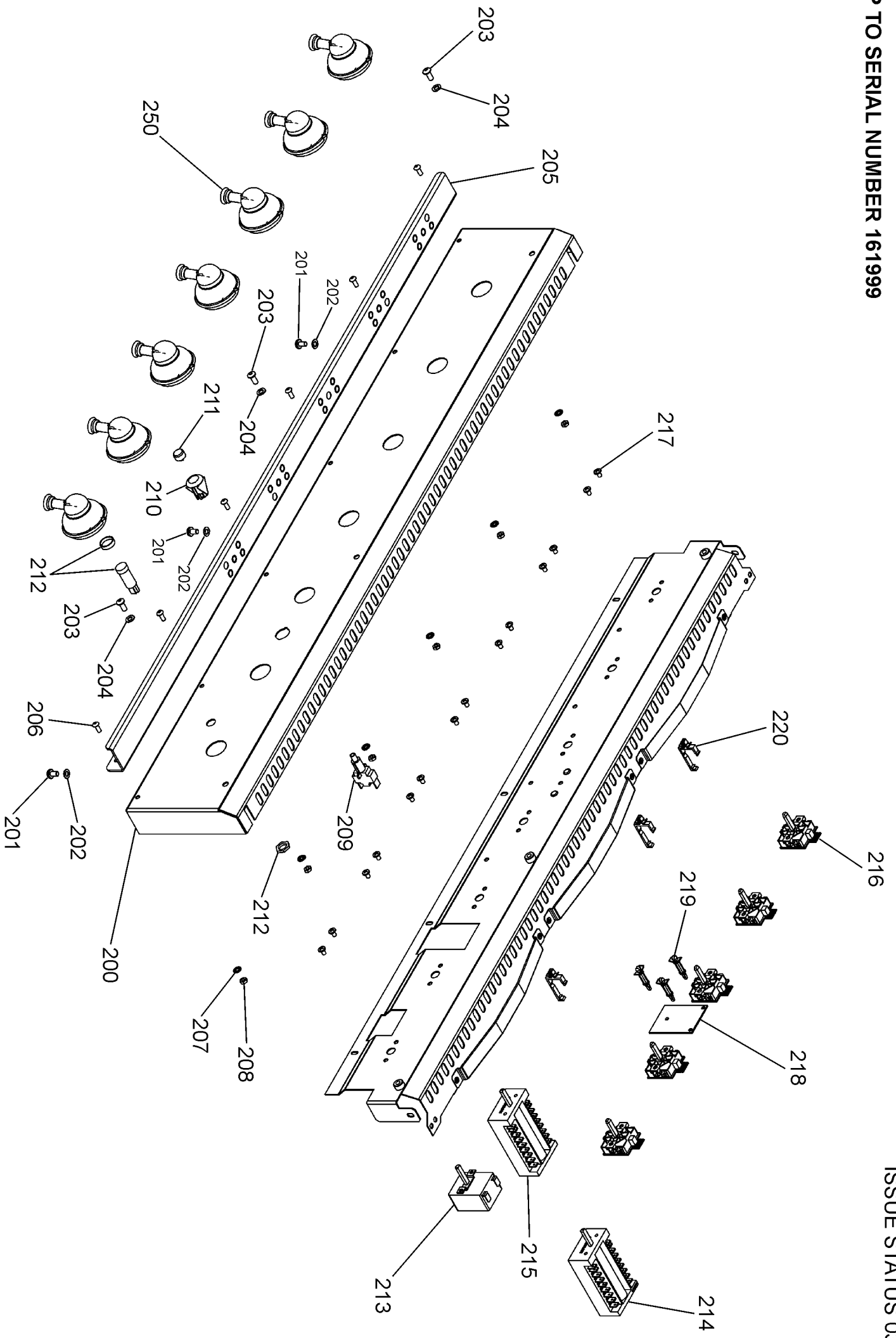

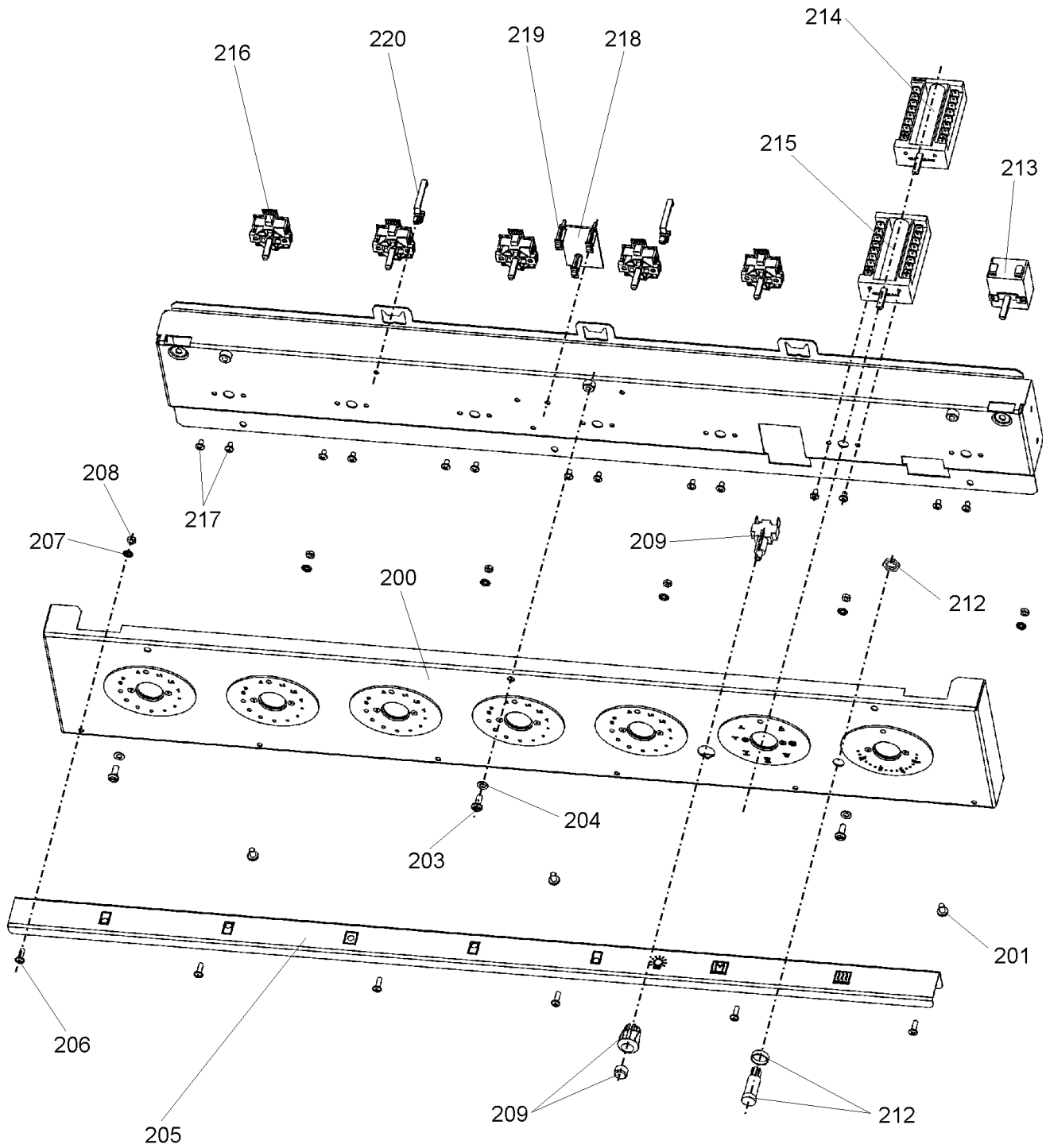

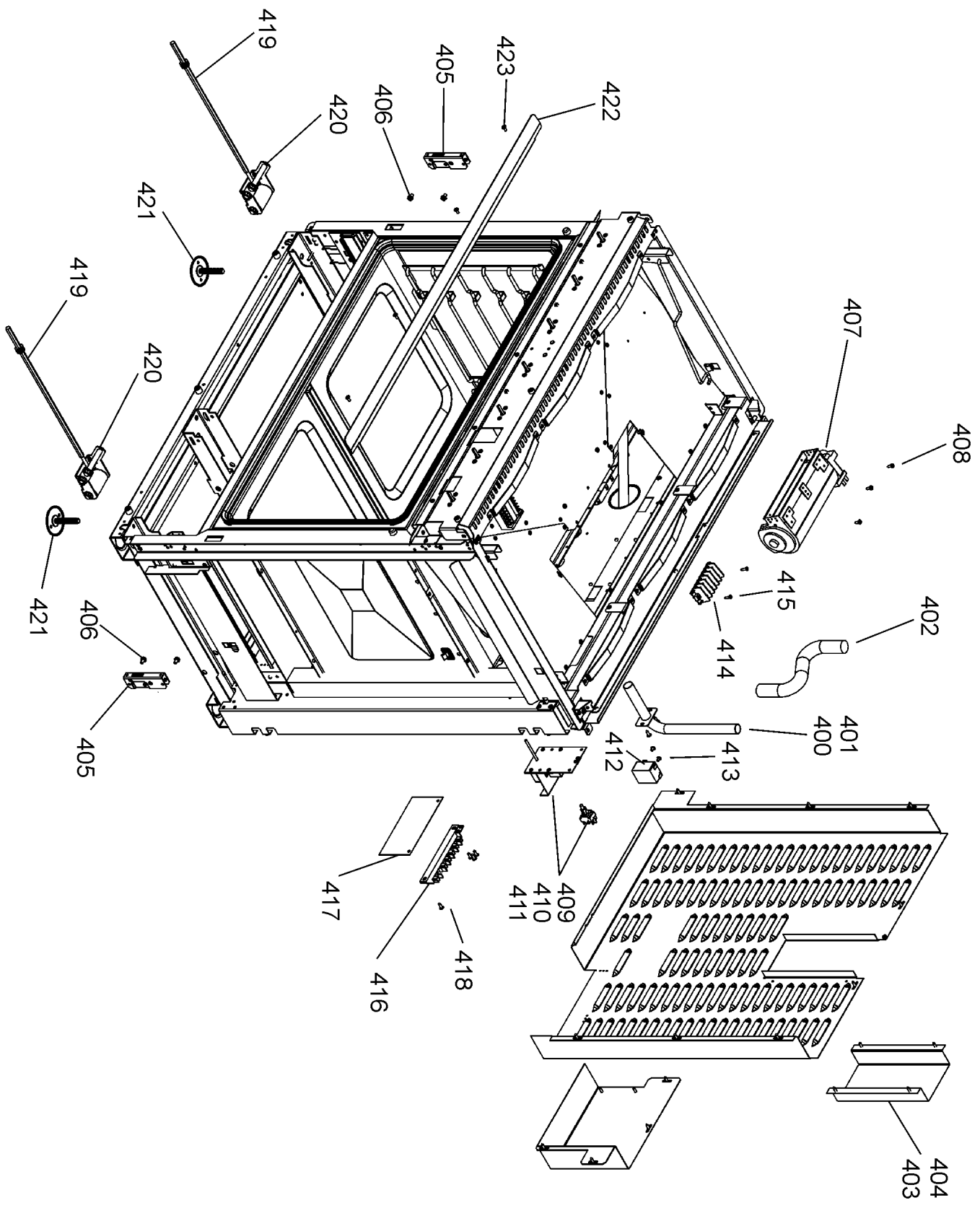

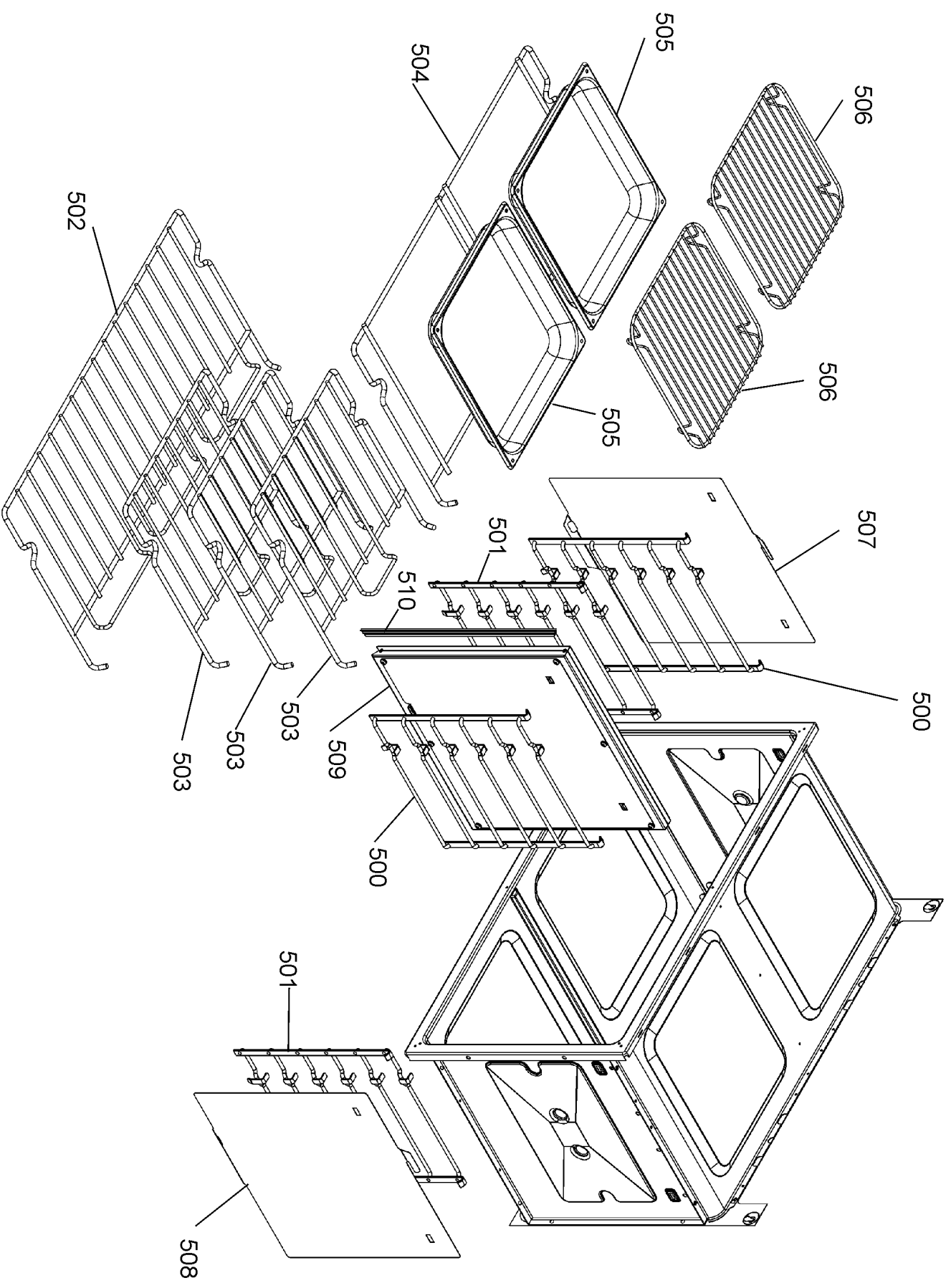

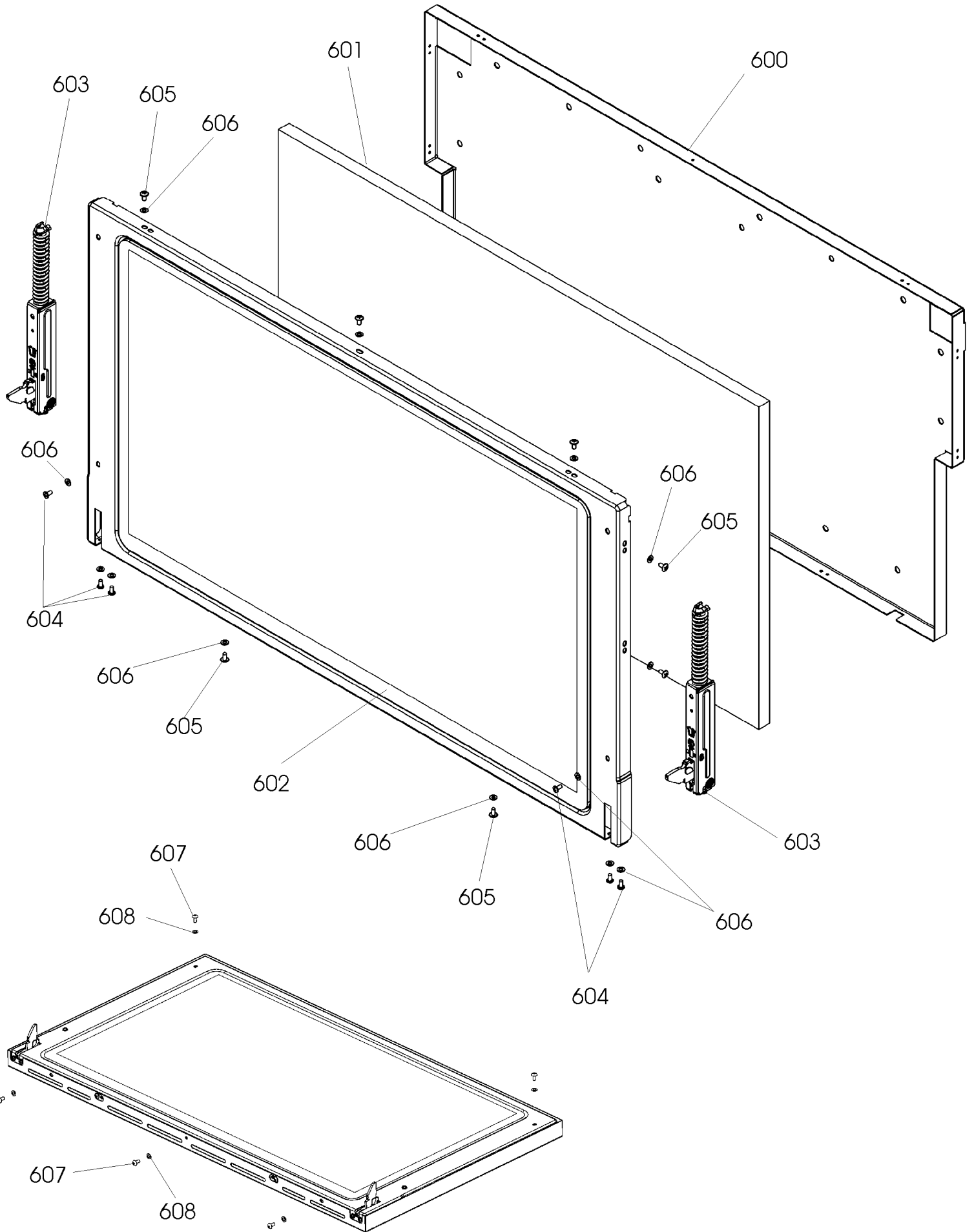

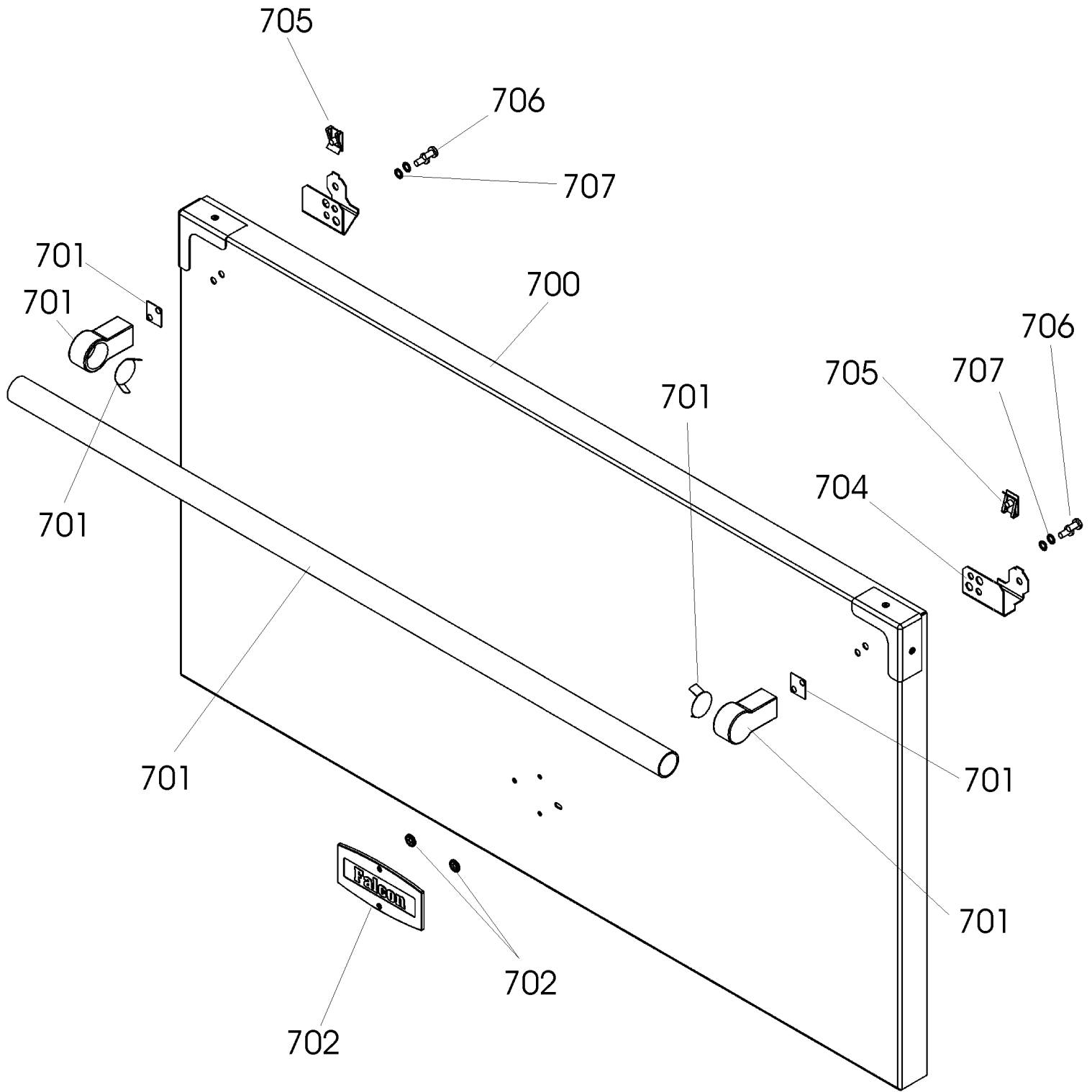

APPLIANCE NAME:
FALCON 900S INDUCTION
UP TO SERIAL NUMBER 119999

DATE 01.07.10

DSL0418 P08
ISSUE STATUS 03

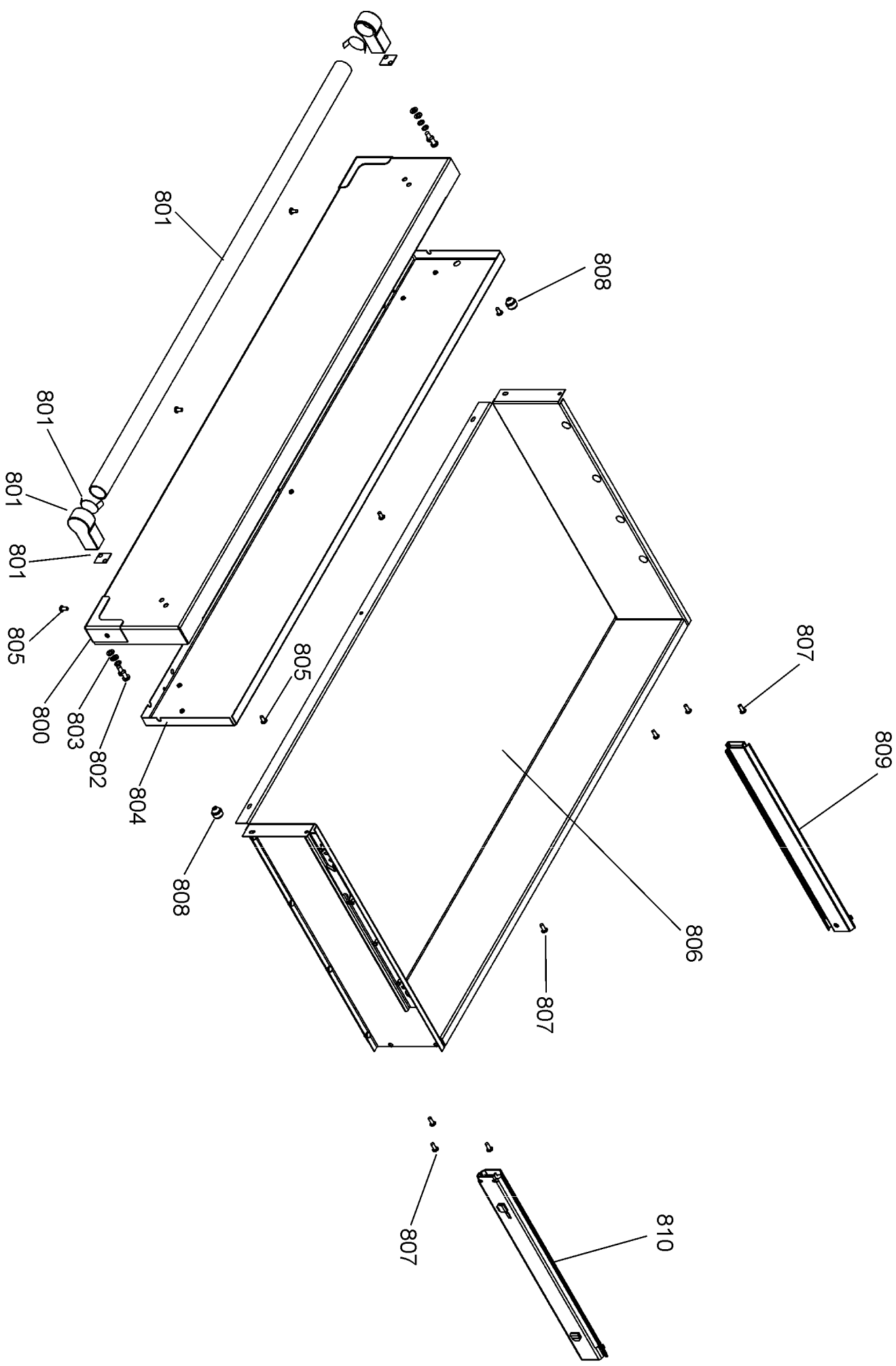

APPLIANCE NAME:
FALCON 900S INDUCTION
FROM SERIAL NUMBER 120000

DATE 01.07.10

DSL0418 P08A
ISSUE STATUS 01

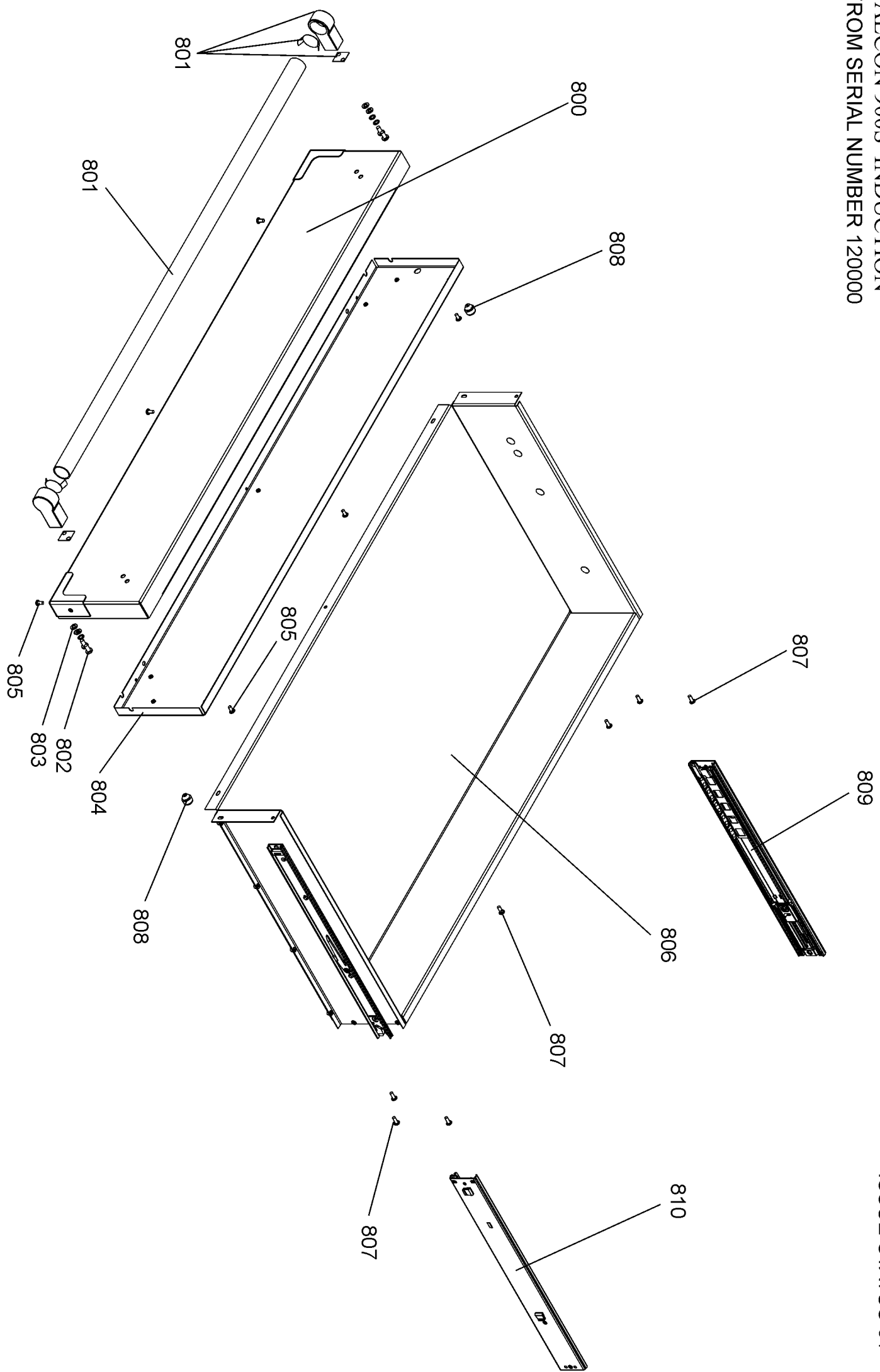

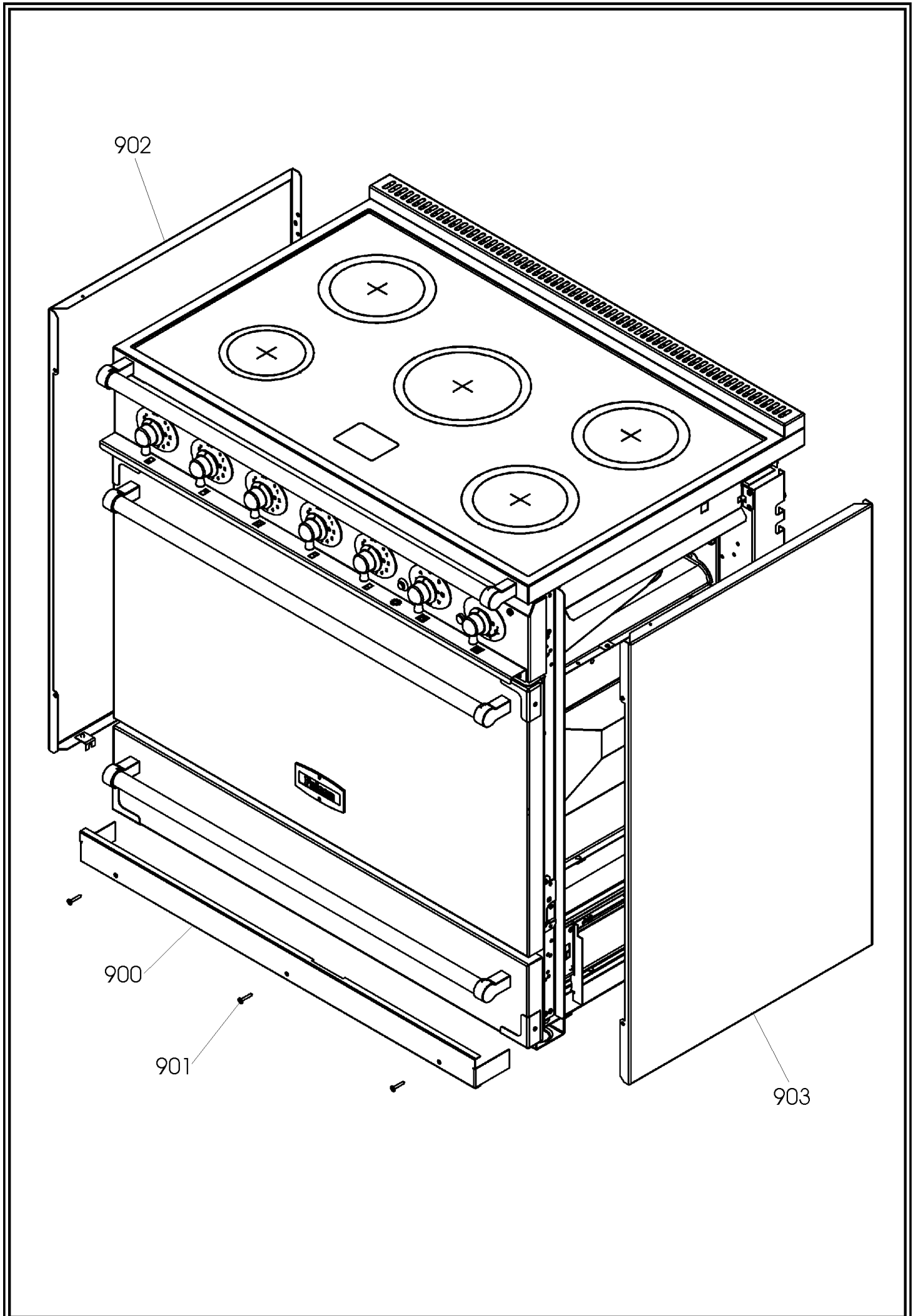

FALCON 900S INDUCTION

UP TO SERIAL NUMBER 161999

DATE 25.07.13

DSL0418 P10
ISSUE STATUS 03

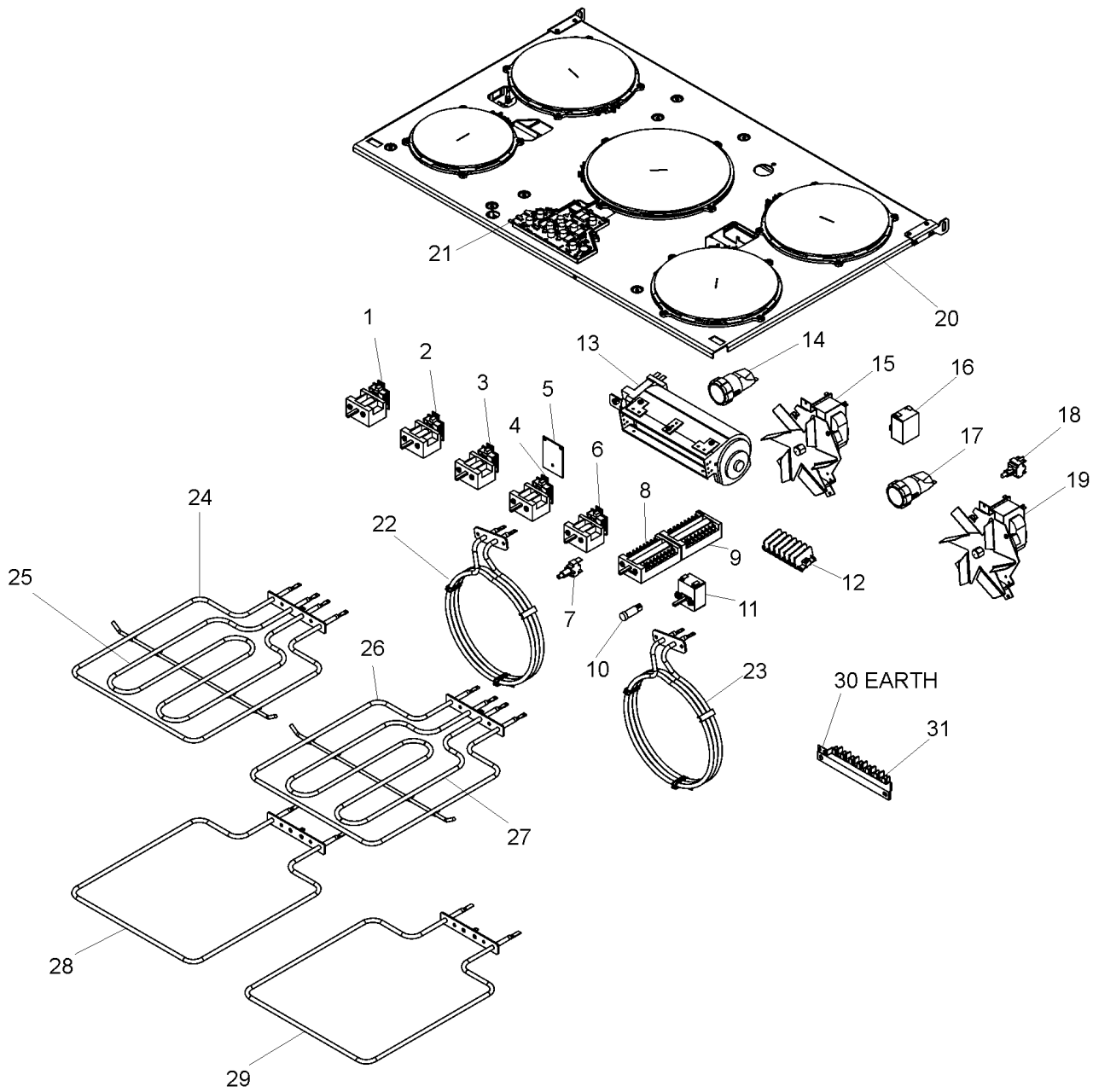

Flag	Harness	FALCON 900 DELUXE INDUCTION	QTY	Connects Components								
				9	11	13	15	22	26	27	29	
950	P045117	MASTER HARNESS	1	9	11	13	15	22	26	27	29	
951	P045118	DRONE HARNESS	1	8	13	18	19	23	24	25	28	
952	P045121	FEED HARNESS	1	7	9	14	16	17				
953	P045123	WIRE ASSY LIGHTS NEUTRAL	1	14	17	31						
954	P045124	WIRE ASSY EARTHS	2	14	15	17	19	22	23	24	25	26
955	P045125	PROTECT FEED	1	16	31							
956	P045216	NEON FEED HARNESS	1	9	10							
957	P040980	HARNESS - TERMINAL BLOCK/BULKHEAD	1	12	30	31						
958	A048380	HARNESS / FERRITE BEAD ASSY	1	12	20							
959	P040924	CABLE - PCB TO ROTARY CONTROL	2	2	5	5	6					
960	P040925	CABLE - PCB TO TOUCH CONTROL	1	5	21							
961	P043936	WIRE ROTARY CONTROL	2	3	4	5	5					
962	P043939	WIRE ROTARY CONTROL	1	1	5							

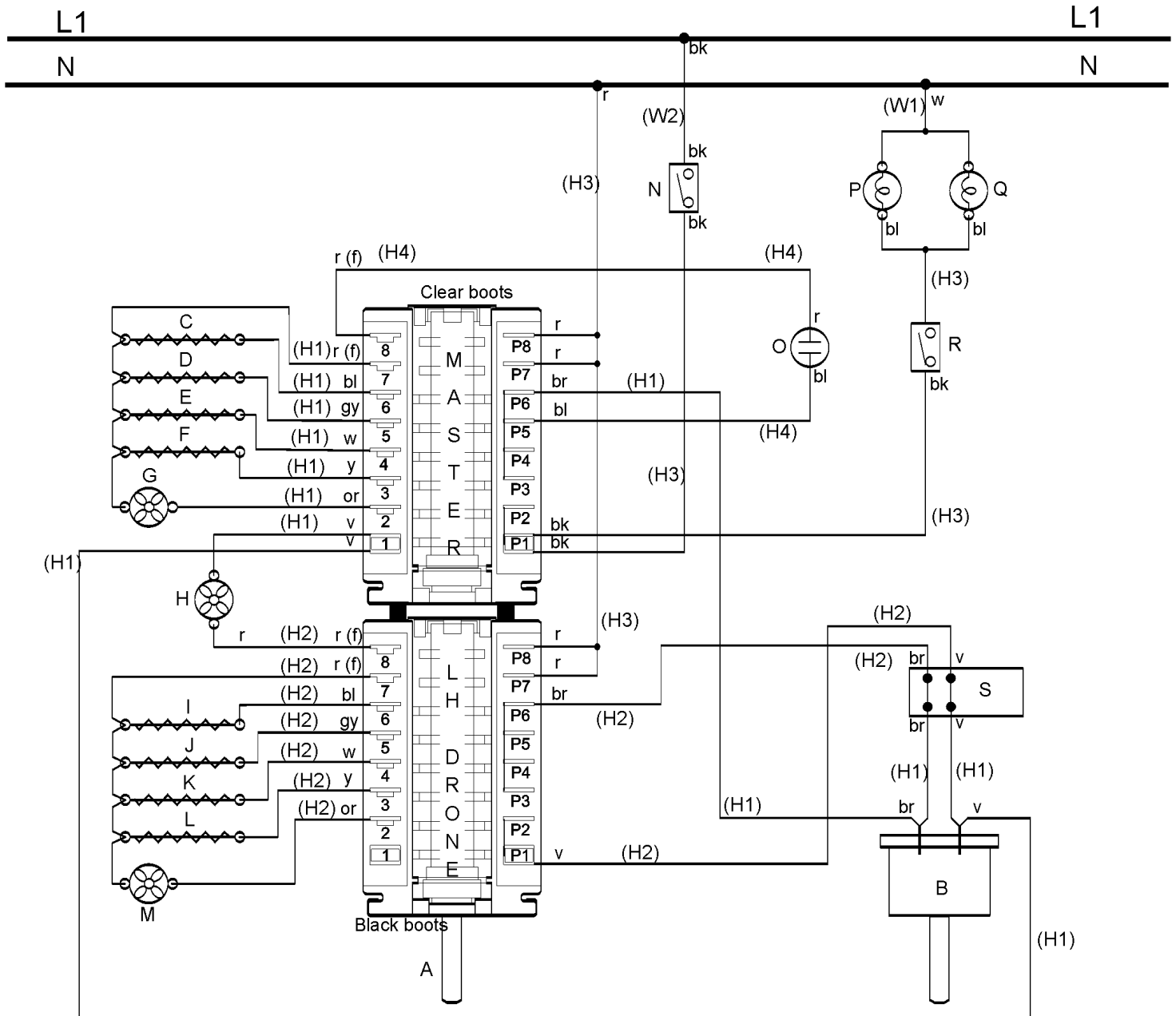

Ref N°	Part N°	Quantity	Remarks
H1	P045117	1	Master harness
H2	P045118	1	Drone harness
H3	P045121	1	Feed harness
W1	P045123	1	Neutral for lights
Ni	P045124	2	Wire assy earth
W2	P045125	1	Protect feed
H4	P045216	1	Neon feed harness
H5	P051610	1	Induction unit to connector block
H6	P052281	1	Terminal block to connector block
W3	P040924	1	Rotary switch to interface board
W4	P051766	1	Hob display to interface board
W5	P043936	2	Rotary switch to interface board
W6	P043937	2	Rotary switch to interface board

Code	Description
A	Function controller
B	Temperature controller
C	Right-hand bottom element
D	Right-hand top element (outer)
E	Right-hand top element (inner)
F	Right-hand fan element
G	Right-hand fan
H	Cooling fan
I	Left-hand bottom element
J	Left-hand top element (outer)
K	Left-hand top element (inner)
L	Left-hand fan element
M	Left-hand fan
N	Thermostat protection
O	Oven neon
P	Oven light
Q	Oven light
R	Oven light switch
S	Divider switch

Code	Colour
bl	Blue
br	Brown
bk	Black
or	Orange
r	Red
v	Violet
w	White
y	Yellow
g/y	Green/yellow
gy	Grey
r(f)	Red (flag)

Induction Hob Circuit Diagram

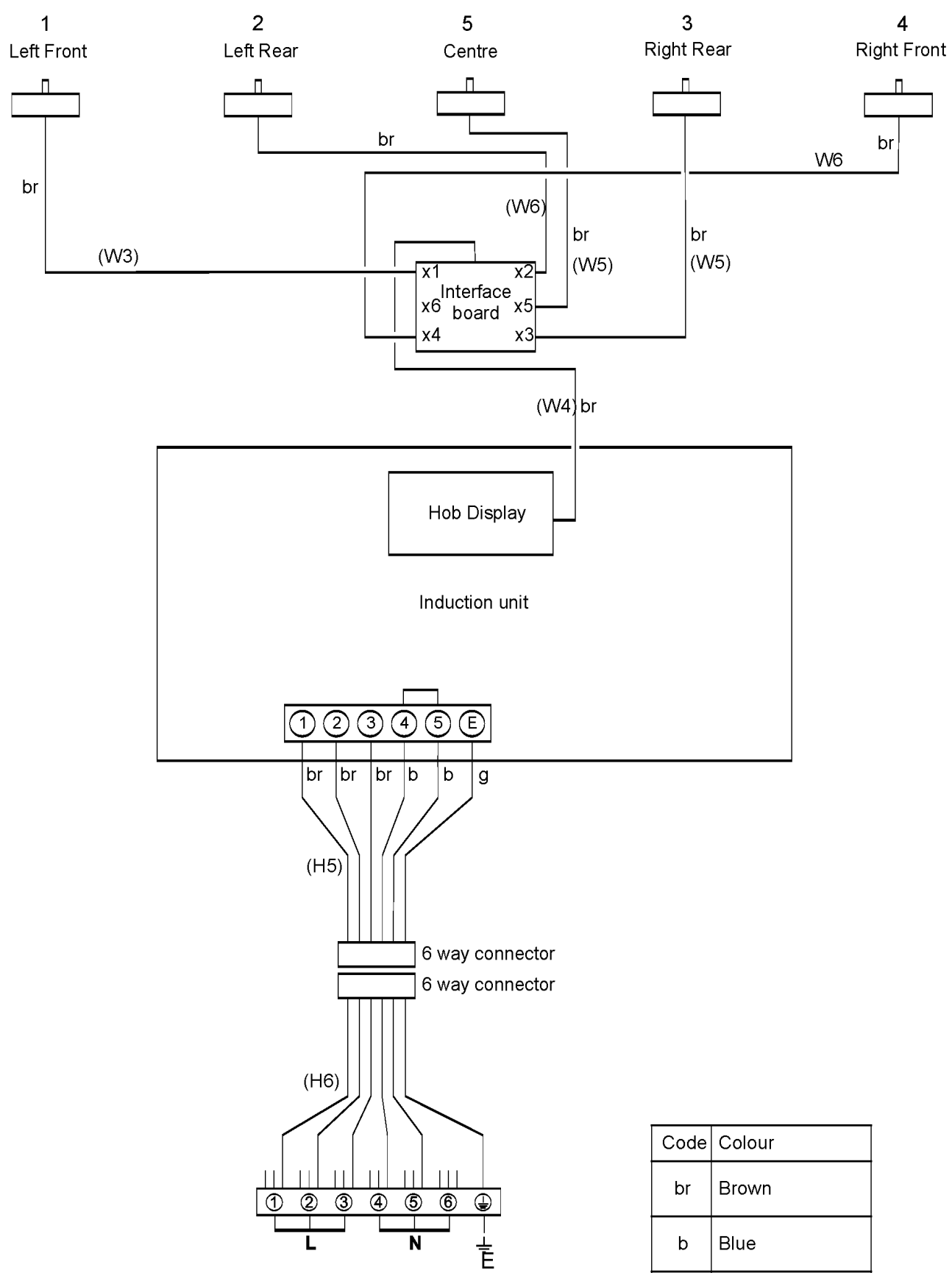

Code	Colour
br	Brown
b	Blue
g	Green