

CLASSIC FX 90 DUAL FUEL

DSL0843 P03

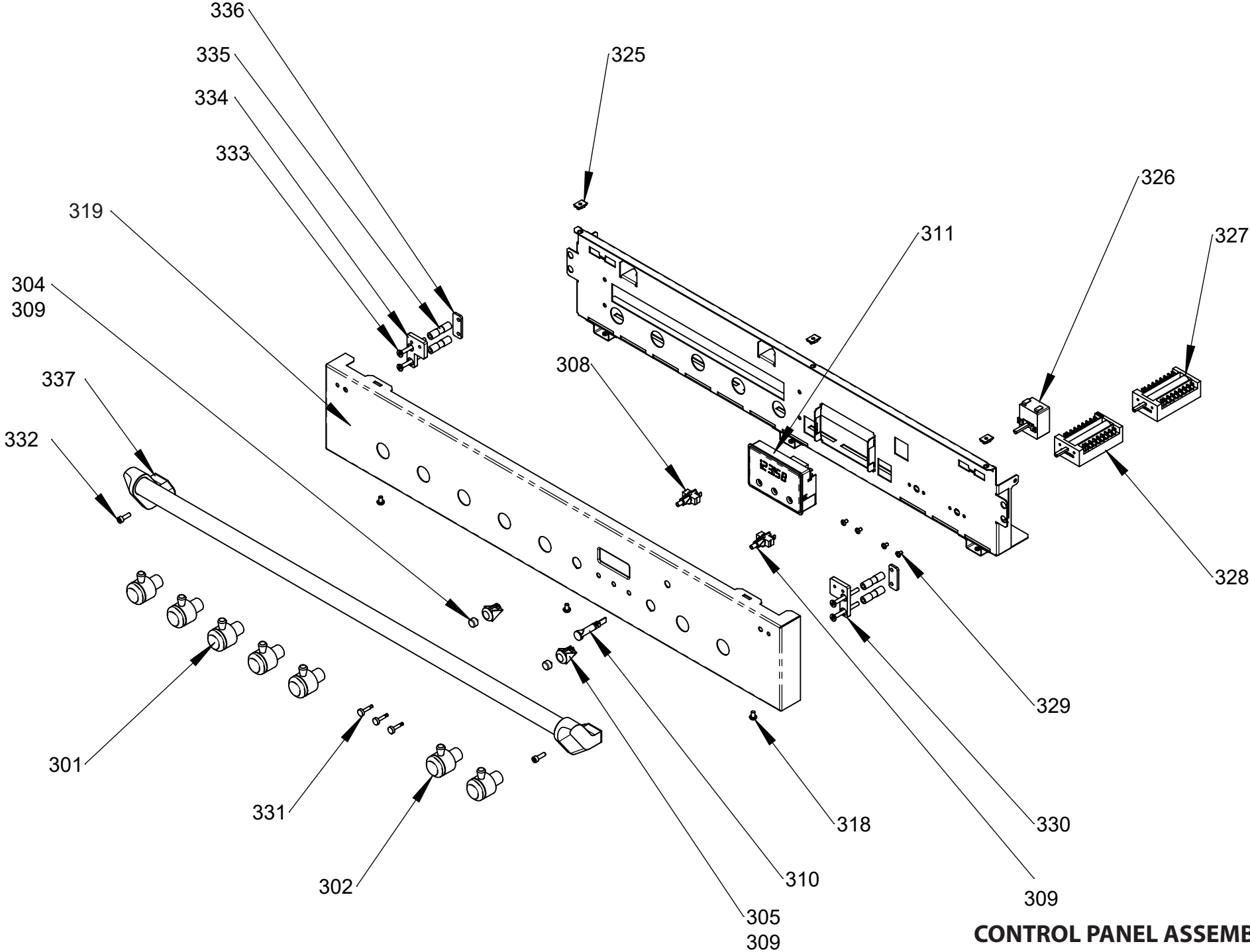

CONTROL PANEL ASSEMBLY

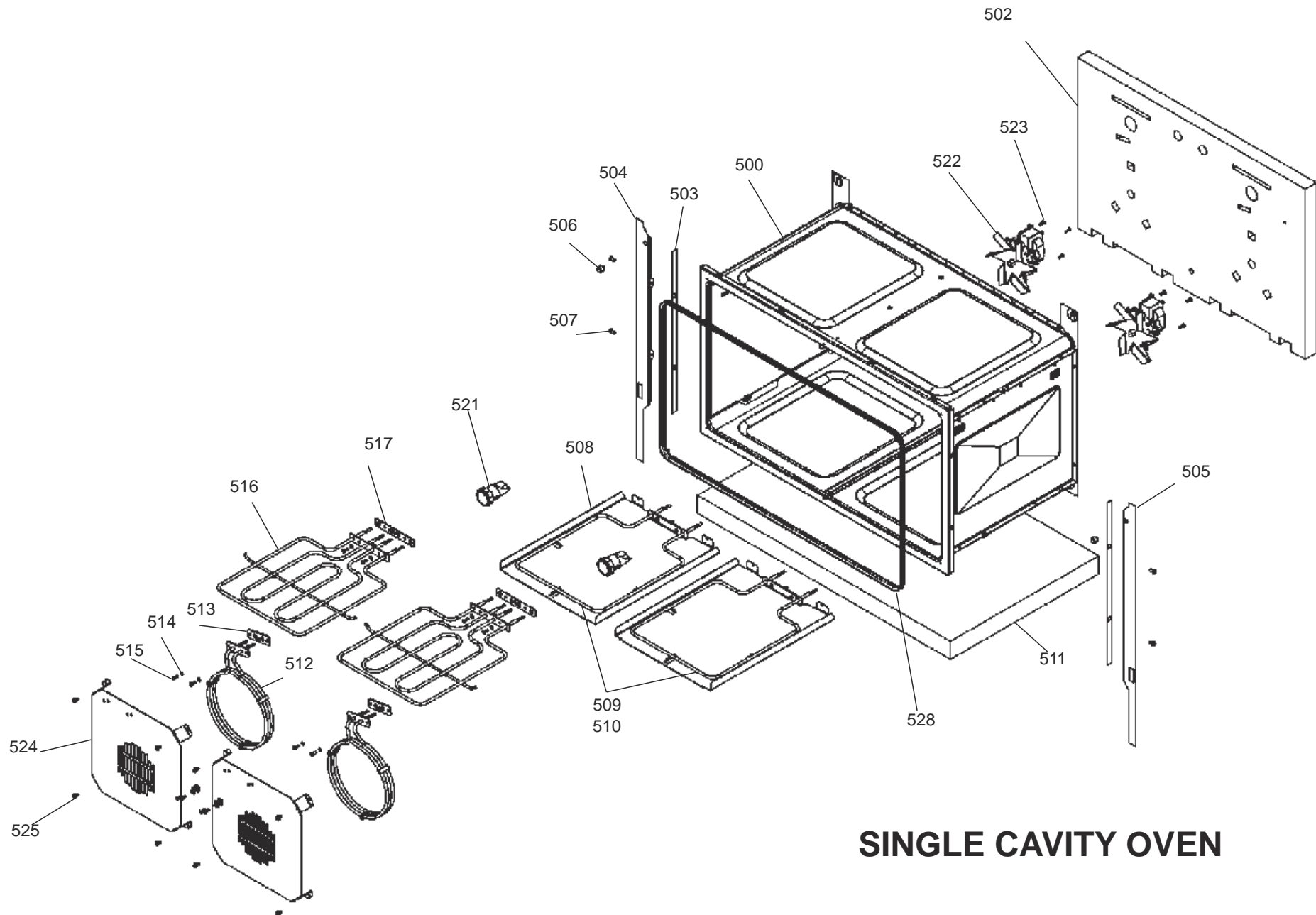

SINGLE CAVITY OVEN

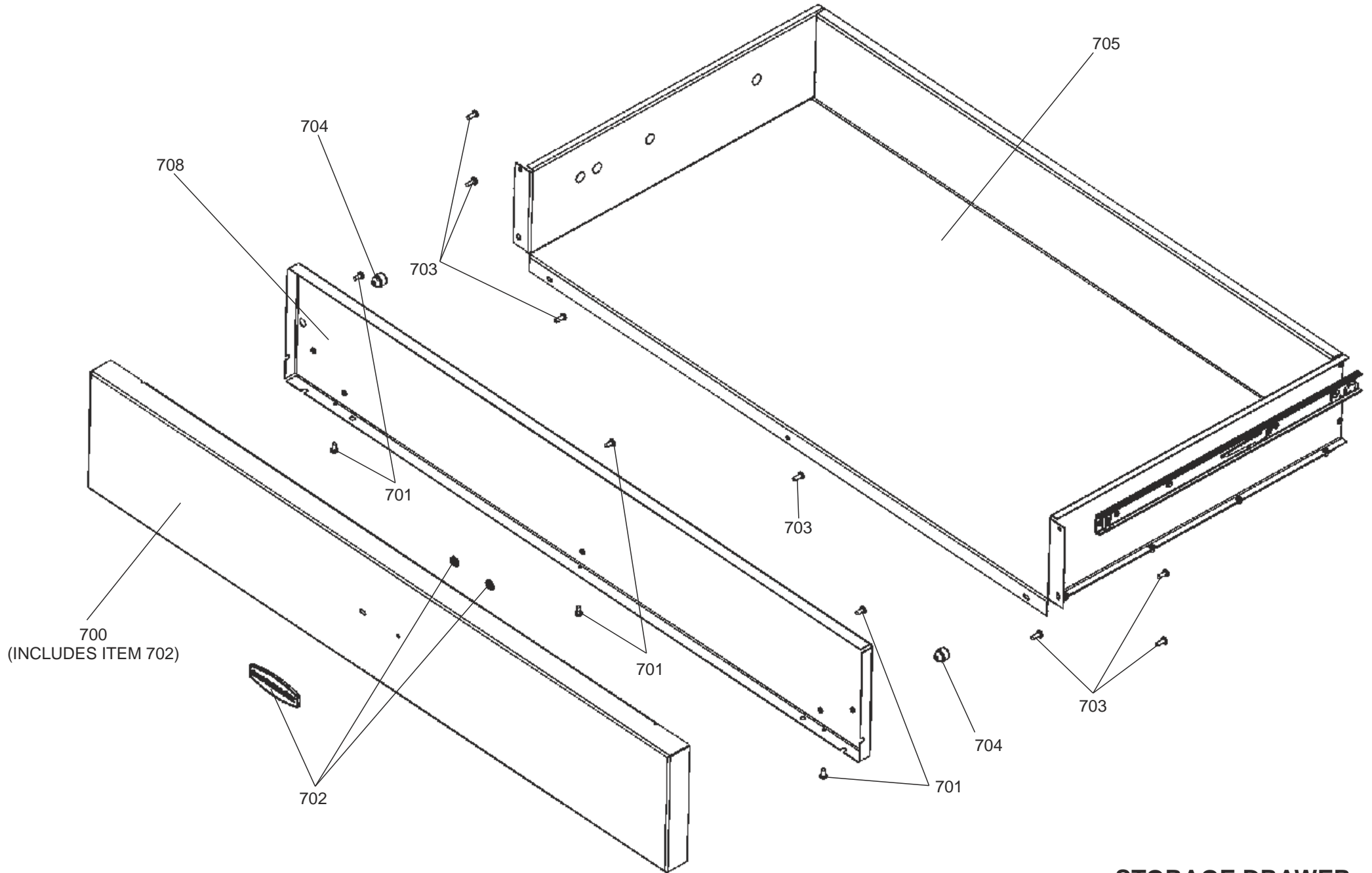

STORAGE DRAWER

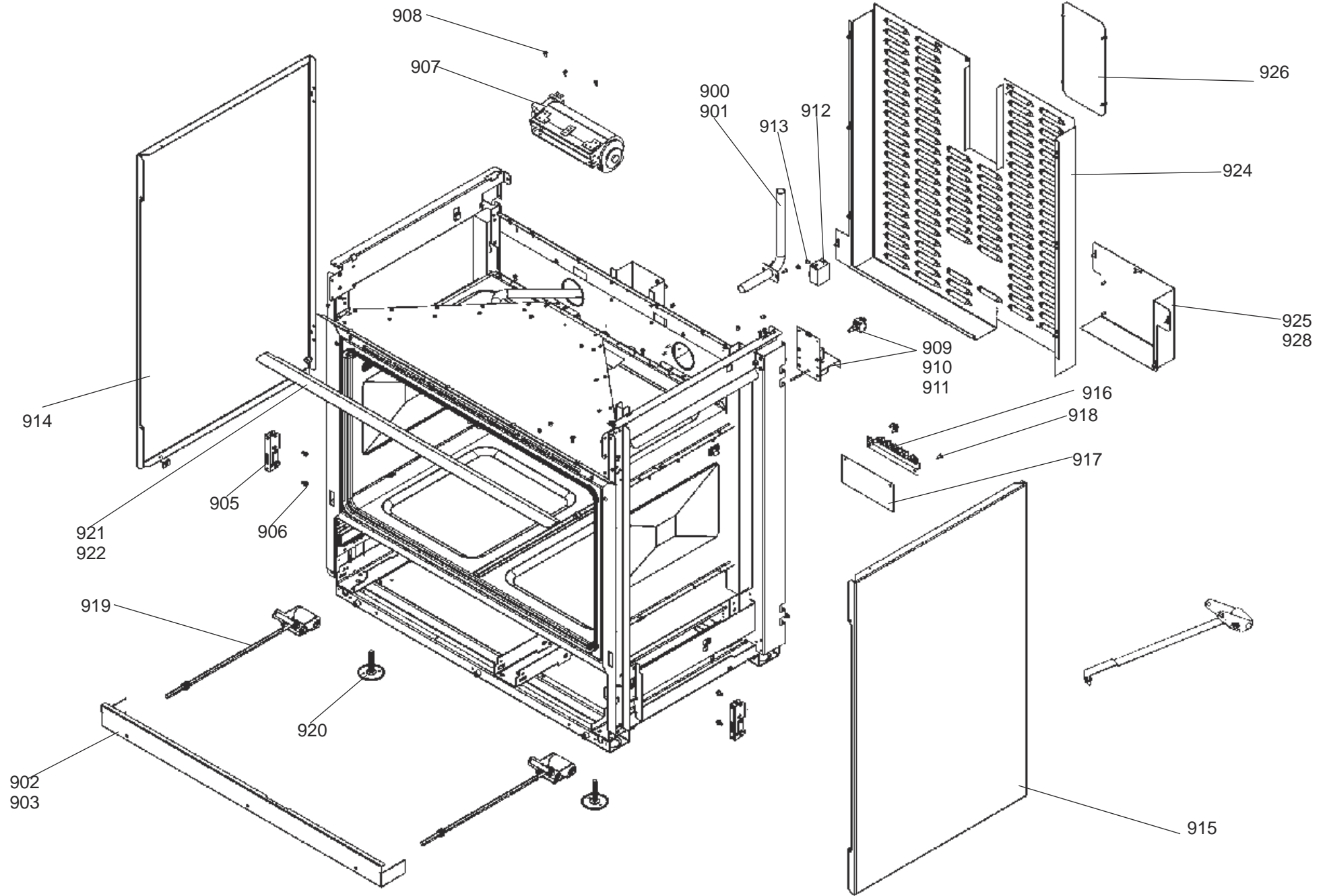

CHASSIS AND FRAME ASSEMBLY

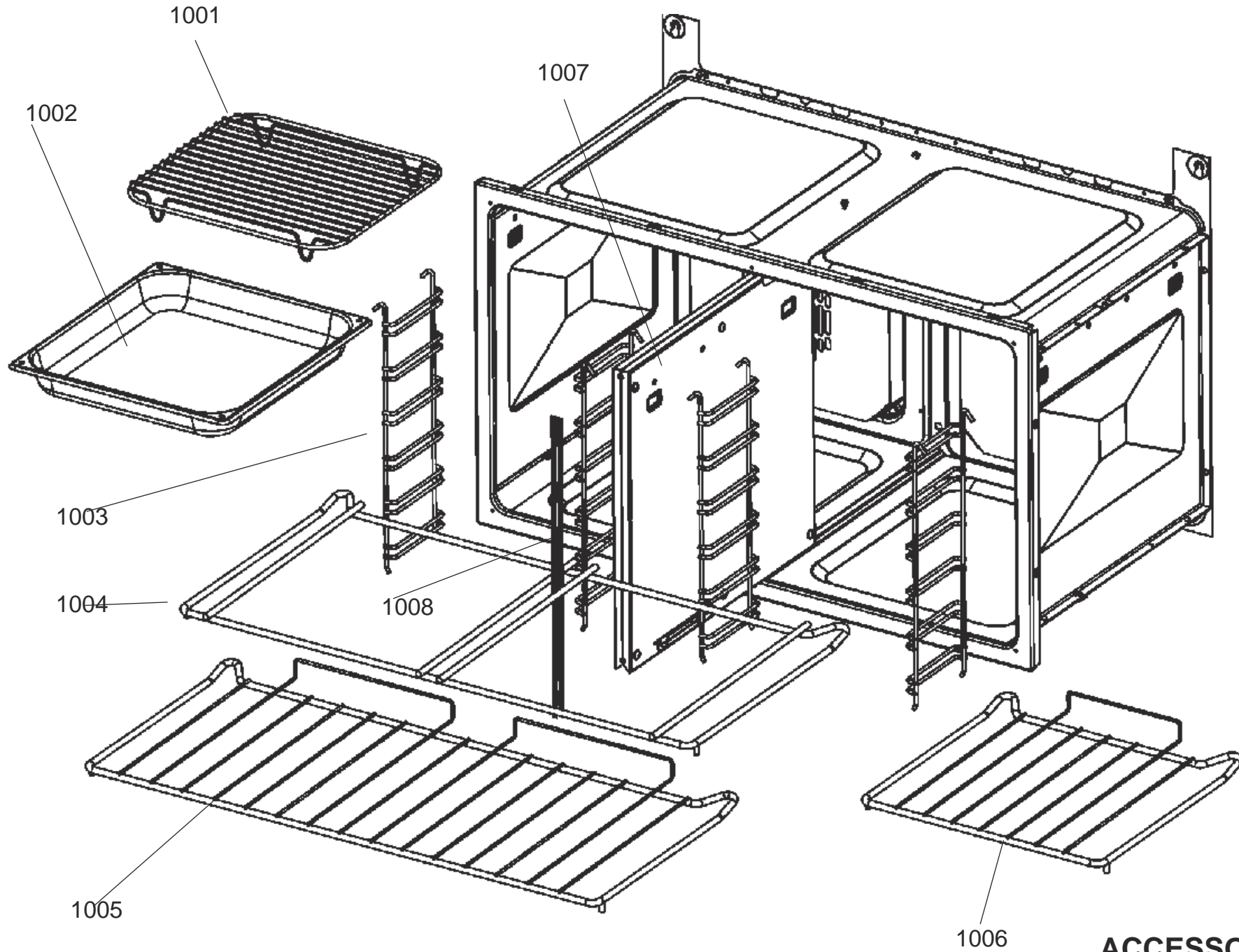

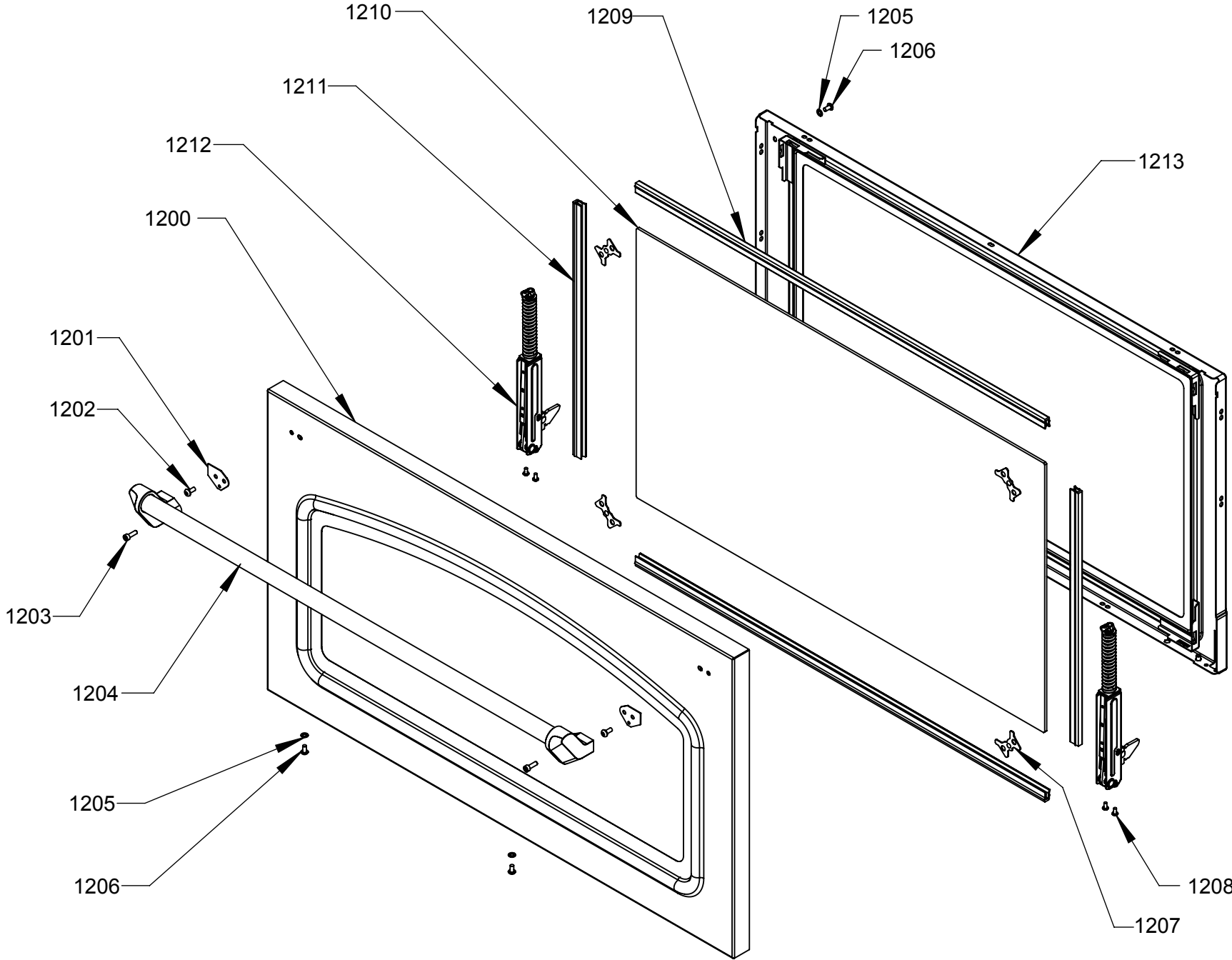

DOOR

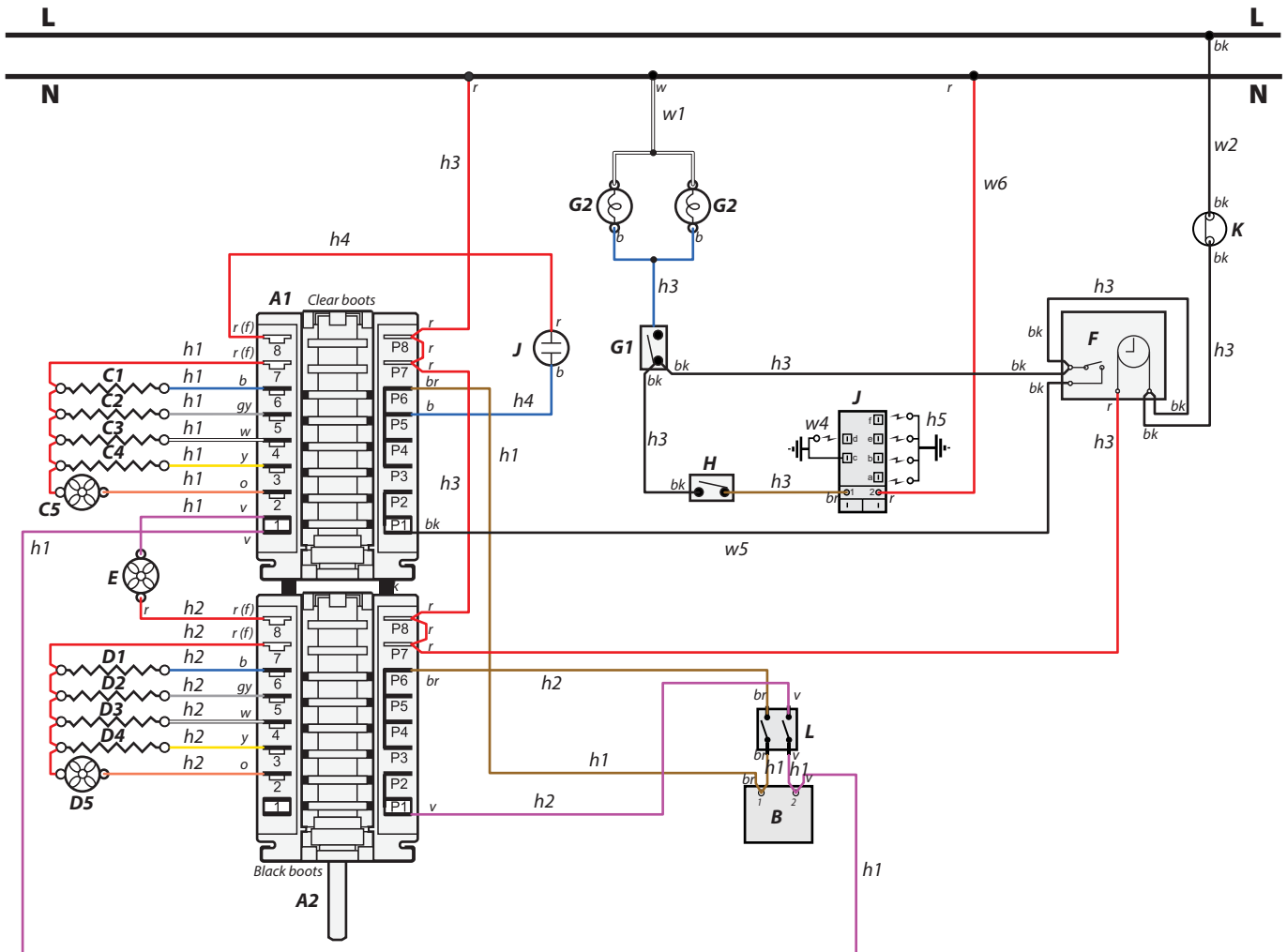

Code	Description
A1	Master function controller
A2	Drone function controller
B	Temperature controller
C1	Right-hand bottom element
C2	Right-hand top outer element
C3	Right-hand top inner element
C4	Right-hand fan element
C5	Right-hand fan
D1	Left-hand bottom element
D2	Left-hand top outer element
D3	Left-hand top inner element

Code	Description
D4	Left-hand fan element
D5	Left-hand fan
E	Cooling fan
F	Clock
G1	Oven light switch
G2	Oven lights
H	Tap switches
J	Spark generator
K	Thermostat protection
L	Oven divider switch

Code	Colour
b	Blue
br	Brown
bk	Black
or	Orange
r	Red
v	Violet
w	White
y	Yellow
g/y	Green/yellow
gr	Grey
r(f)	Red